

The Pentek Pipeline

A quarterly publication for engineering system design and applications.

Pentek, Inc.

One Park Way, Upper Saddle River, NJ 07458
 Tel: (201) 818-5900 • Fax: (201) 818-5904
 email: pipeline@pentek.com
 http://www.pentek.com

© 2013 Pentek, Inc. Newsletter Editor: TNT Resources, LLC.
 Trademarks are properties of their respective owners.
 Specifications are subject to change without notice.

In This Issue

- Originally designed for high-availability and cost-effective telecom systems, the ATCA using AMC modules has evolved to MicroTCA. More in the feature article.

"The MicroTCA backplane system with a wealth of AMC modules makes it possible to develop a high-speed data acquisition system for specific application needs."

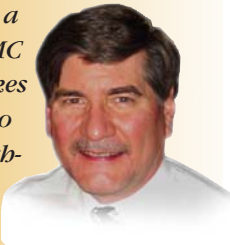

Rodger Hosking, Pentek Vice President and Co-founder

- **Product Focus:** [starts on page 4](#)
- **Cobalt and Onyx Sale:** [page 10](#)

Free Technical Resources

- [Sign up for free subscription to The Pentek Pipeline](#)
- [Sign up for Virtex-7 Onyx product updates](#)
- [2nd](#) edition of the [High-Speed Recording Systems Handbook](#)
- [6th](#) edition of the [High-Speed Switched Serial Fabrics Handbook](#)
- [10th](#) edition of the [SDR Handbook](#)
- [7th](#) edition of the [FPGAs for Software Radio Systems Handbook](#)
- [8th](#) edition of the [High-Speed A/Ds Handbook](#)

MicroTCA/AMC Solutions for Real-Time Data Acquisition

Originally designed for high-availability and cost-effective telecom systems, the ATCA (Advanced Telecommunications Computing Architecture) using AMC (Advanced Mezzanine Card) modules has evolved to MicroTCA, an evolving standard now capturing design wins for an increasing share of embedded real-time applications. Based on a well-defined gigabit serial backplane and switch topology, the MicroTCA, or μ TCA, platform provides a fast, flexible infrastructure for plug-in AMC modules, now available with functions well beyond traditional telecom. High-speed A/Ds, D/As and the latest FPGAs on new AMC modules take advantage of fast PCIe links to deliver data rates for demanding real-time data acquisition systems while lowering the cost over alternative architectures.

Real-Time Data Acquisition

In the purest sense, real-time data acquisition simply means acquiring data at a specified rate with the guarantee of no data loss. However, diverse markets are driving these rates to exponentially higher levels.

In most cases, data acquisition includes digitization of sensor signals followed by transmission, buffering, storing and processing. Communication systems for commercial and military applications struggle to meet user demands for more information. These applications include high-definition imaging, video and audio programming, streaming internet content, email traffic, large data files, and cloud storage for databases. Radar systems operating with new wideband waveforms, not only detect speed, range and direction of travel, but also capture complex information for target classification, and identification. Likewise, sonar, medical imaging, and security-scanning systems are migrating to higher resolution and higher frame rates.

These factors boost the required bandwidth for each signal channel. But because many of the sensors now have multiple elements, the number of channels is growing as well. As a result, demands on data acquisition hardware and sys-

tem infrastructure have outstripped older open-architecture embedded systems due to data transfer bottlenecks into and across the backplane. Not only must sensor signals be digitized, but the data must also be delivered to useful system destinations such as shared memory, communication links or storage disks.

As an example, a four-channel 200 MHz 16-bit A/D converter is a relatively popular configuration for embedded data acquisition in many of the above applications. Operating at full speed, one such module generates data samples at a rate of 1600 MB/sec.

Parallel-bus architectures such as VMEbus or CompactPCI, with peak data transfer capacities across the backplane between 160 and 800 MB/sec, are completely overwhelmed by just a single module. This shortfall spurred the development of gigabit serial backplanes and motherboards including standards such as PCI Express, OpenVPX, CompactPCI Serial, ATCA, MicroTCA and others.

Highlights of MicroTCA and AMC

In 2005, ATCA vendors announced a replacement for the older parallel-bus PMC modules found on the first ATCA boards. These new mezzanine modules (AMCs) are daughter cards that add various analog and digital I/O functions to ATCA system boards, including A/D and D/A converters, DSPs, FPGAs, CPUs, network interfaces for copper and optical links, graphics engines and storage interfaces. Offered in six different sizes, they support several different chassis and carrier board shapes. Figure 1 on the next page, shows the Pentek Model 56660 4-Channel 200 MHz A/D AMC, a single-width, full-height module based on the AMC.1 Specification that defines PCIe as the backplane fabric interface. It consists of a carrier board housing an XMC module, with its fast PCIe Gen. 2 x4 interface delivered to the backplane connector.

AMC modules offer many advantages that are directly suitable to real-time data acquisition. They support hot-swap capability and IPMI (Intelligent Platform Management Interface) ►

MicroTCA/AMC Solutions for Real-Time Data Acquisition

features for high availability, built-in testing, and performance monitoring for mission critical applications.

AMCs offer a rich collection of gigabit serial interfaces including GbE (Gigabit Ethernet) to system controllers, SATA (Serial ATA), SAS (Serial-Attached SCSI) or FC (Fibre Channel) links to storage peripherals, and XAUI (10 GbE Attachment Unit Interface), PCIe or SRIO (Serial RapidIO) links for high-speed data transfer through the system connector.

As AMC modules rapidly gained popularity, developers sought a way to retarget them as independent plug-in modules for a simple backplane system architecture instead of as daughter cards for ATCA carrier boards. This effort evolved to the MicroTCA architecture. Many of the concepts from ATCA were pulled forward into this new MicroTCA mechanical chassis configuration to take advantage of the wealth of system management, protocol, and industry infrastructure already in place for ATCA.

The MicroTCA Carrier is an essential aspect of this new architecture. Shown in Figure 2, the Carrier incorporates all elements of a complete system and typically accepts twelve AMC modules. These include a card cage or “shelf” to house the plug-in AMC modules and a backplane that engages with all of the power and signal pins on the AMC connectors. Also connected to the backplane are one or two MCHs (MicroTCA Carrier Hubs), one to four PMs (Power

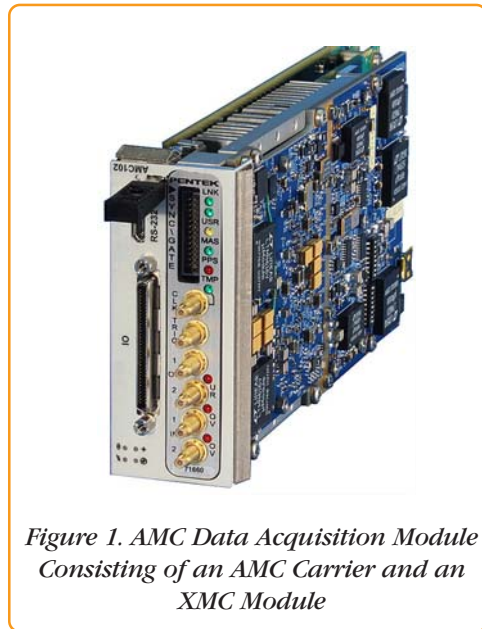

Figure 1. AMC Data Acquisition Module Consisting of an AMC Carrier and an XMC Module

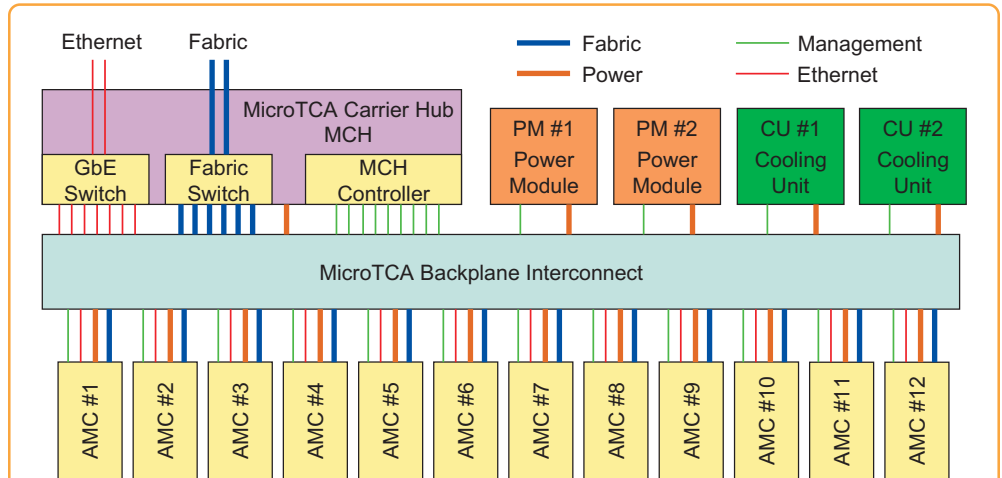

Figure 2. Typical 12-slot MicroTCA Architecture



Figure 3. Typical 12-slot MicroTCA Shelf

Modules), and one or two CUs (Cooling Units).

The MCH includes fabric and Ethernet switches for at least one GbE port plus four lanes of XAUI, PCIe or SRIO to each of the twelve AMC modules. In this way, all of the AMC modules can communicate over Ethernet and send fabric data to each other.

The MCH also provides a fabric channel uplink and Ethernet ports to other systems.

The MCHM (MicroTCA Hub Management Controller) performs management services for twelve AMCs, four Power Modules and two Cooling Units. Other MCHM functions include shelf management, clock distribution, and alarms.

MicroTCA System Example

Because of the fast gigabit serial fabric links, MicroTCA offers an attractive platform for high-speed data acquisition systems. As an example, the Pentek Model 56660

AMC module in Figure 1 is quite suitable as the front end of a real-time recording system. The four A/D converters digitize front-panel analog inputs, each producing 200 MSamples/sec. With two bytes per sample, this means 400 MB/sec per channel, or 1600 MB/sec for the 4-channel AMC module. This rather demanding traffic load can be accommodated through the PCIe Gen 2 x4 backplane fabric interface, which supports a peak transfer rate of 2000 MB/sec.

Figure 4 on the next page shows a simplified block diagram of a complete MicroTCA recording system, showing connectivity of the important PCIe fabric links. An SBC (Single Board Computer) AMC module hosts the operating system and provides system memory accessible through its PCIe link to the MCH switch. A RAID Controller AMC module, also connected via PCIe through the MCH fabric switch, offers eight SATA-III ports to eight solid-state drives, ▶

MicroTCA/AMC Solutions for Real-Time Data Acquisition

each capable of read/write speeds of over 300 MB/sec.

Pentek's SystemFlow software runs on the SBC to orchestrate real-time data transfers among these three AMC modules by managing hardware DMA (Direct Memory Access) controllers using the PCIe fabric links. Parameters are sent to these linked-list DMA engines to specify the size and destination of data blocks to be moved to or from system memory on the SBC. Once a DMA block transfer is completed, the next DMA operation starts automatically, and the CPU receives a notification interrupt so it can monitor progress.

Specifically the DMA controller on the AMC data acquisition module moves blocks of A/D data into circular buffers on system memory of the SBC. Then, the DMA controller on the RAID controller AMC moves data from completed system memory blocks to the RAID controller. Finally, the RAID controller "stripes" data by writing simultaneously across eight SSDs to achieve aggregate storage speeds to the RAID array of over 2000 MB/sec.

This scheme ensures that the CPU does not touch any data, so that Windows or Linux host operating systems impose no adverse effect on maintaining sustained real-time recordings. Also, the data on the RAID array is stored in NTFS format so it is immediately available for analysis, display or processing applications running on the host CPU.

MicroTCA: Ready for Real-Time

Its well-defined, fast and straightforward architecture makes MicroTCA a serious contender for high-end, real-time embedded

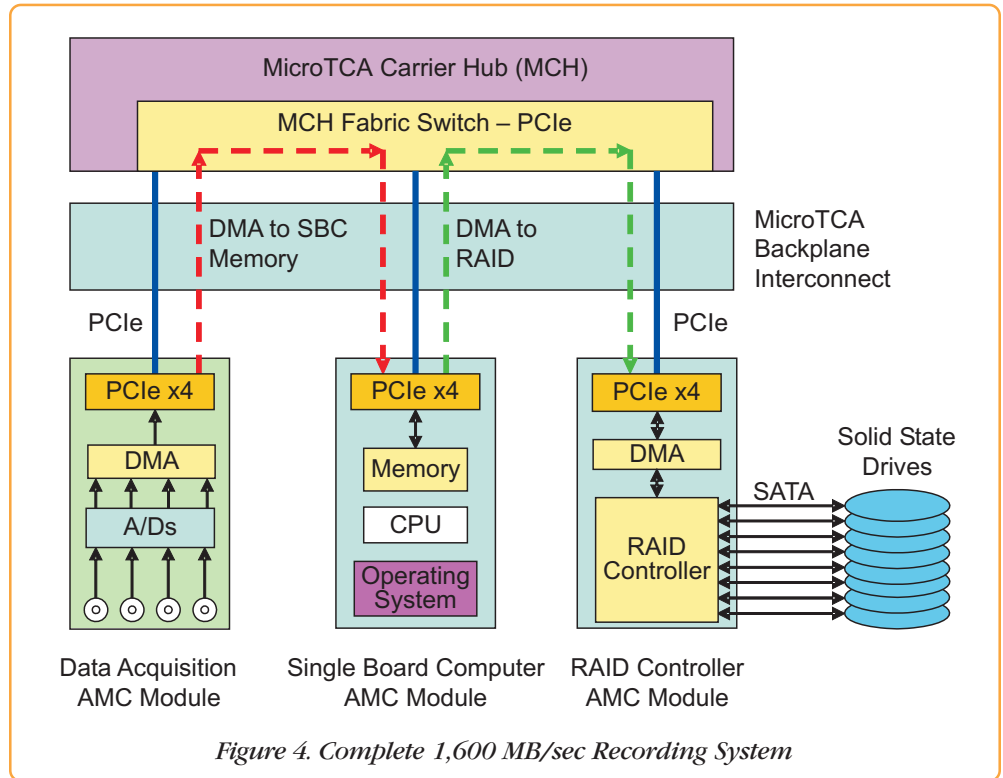

Figure 4. Complete 1,600 MB/sec Recording System

systems. Using popular gigabit serial fabrics like XAUI, PCIe and SRIO, it delivers substantial backplane bandwidth, more than adequate for many applications. It also provides a rich system infrastructure that includes various form factors, power and cooling strategies, system management facilities, high availability and redundancy features, all in a highly modular design.

Because of the wealth of MicroTCA products available for the cost-sensitive telecom community, systems are often 20% to 40% less expensive than comparable systems using more traditional embedded card cage

architectures. Extensions to the base specification now support ruggedized MicroTCA systems with both air- and conduction-cooled AMC modules, including specifications for shock, altitude and vibration required for many government and military applications.

System level software written for PCIe or SRIO systems is highly portable to MicroTCA because of the standard fabric interconnects and the operating systems supported by available SBC AMC modules. All in all, MicroTCA is definitely worth considering for your next data acquisition system. □

Downloadable Segment & Product Catalogs



[Analog & Digital I/O Segment Catalog](#)



[Clock & Sync Generators Segment Catalog](#)



[Radar & SDR I/O Segment Catalog](#)



[Software & FPGA Tools Segment Catalog](#)



[High-Speed Recorders Segment Catalog](#)



[Onyx/Cobalt Catalog](#)

Product Focus

AMC Products

Pentek Launches Extensive Line of AMC Products for Signal Processing I/O

Pentek has just launched a 16-member family of AMC (Advanced Mezzanine Card) products giving customers instant access to the extensive line of signal processing products in the Pentek catalog.

Pentek is leveraging their modular product architectures to bring a large array of options to market in a very short time. The Pentek 56xxx products fill a major I/O product gap in the AMC ecosystem by offering 16 different modules.

Many new defense programs are evaluating AMCs because of the small form factor packages and chassis. The built-in support for IPMI and the existing infrastructure of modules, systems and software provide a reliable computing platform strategy for many applications. AMCs keep the performance level high while keeping system cost down.

The AMC.1 products are derived from the Pentek Cobalt® product family based on Xilinx Virtex-6 FPGAs with PCI Express Gen. 2 system interfaces; and the Pentek Onyx® product family using Xilinx Virtex-7 FPGAs with PCI Express Gen. 3 interfaces. I/O functionality in the 56xxx family includes analog-to-digital and digital-to-analog converters, multiband digital receivers, upconverters, downconverters and transceivers.

Pentek responded to customer requests by offering its entire line of Onyx and Cobalt products in the AMC form factor, thereby helping customers implement cost-effective systems. The Pentek 56xxx AMC product line opens many new markets for its popular Cobalt and Onyx product families.

AMC is the PICMG specification that defines the small form factor modules. AMC modules can be used directly in a MicroTCA chassis creating a powerful data acquisition and processing system in a small footprint. A summary of the available AMC products today is shown in the nearby table. Additional models are expected to be available in the very near future.



Model	Description	Xilinx FPGA
Model 56620	Triple 200 MHz A/D, DUC and Dual 800 MHz D/A	Virtex-6
Model 56621	Triple 200 MHz A/D with DDC, DUC and Dual 800 MHz D/A	Virtex-6
Model 56660	Quad 200 MHz, 16-bit A/D	Virtex-6
Model 56661	Quad 200 MHz 16-bit A/D with Quad DDC	Virtex-6
Model 56662	Quad 200 MHz 16-bit A/D with 32-Channel DDC	Virtex-6
Model 56690	L-Band RF Tuner and Dual 200 MHz A/D	Virtex-6
Model 56720	Triple 200 MHz A/D, DUC and Dual 800 MHz D/A	Virtex-7
Model 56760	Quad 200 MHz, 16-bit A/D	Virtex-7
Model 56650	Dual 500 MHz A/D, DUC and Dual 800 MHz D/A	Virtex-6
Model 56651	Dual 500 MHz A/D, DDC, DUC and Dual 800 MHz D/A	Virtex-6
Model 56630	Single 1 GHz 12-bit A/D and 1 GHz 12-bit D/A	Virtex-6
Model 56670	Quad 1.25 GHz, DUC and 16-bit D/A	Virtex-6
Model 56671	Quad 1.25 GHz, DUC w. Extended Interpolation, and 16-bit D/A	Virtex-6
Model 56640	Single 3.6 GHz or Dual 1.8 GHz 12-bit A/D	Virtex-6
Model 56641	Single 3.6 GHz or Dual 1.8 GHz 12-bit A/D with DDC	Virtex-6
Model 56611	Quad Serial FPDP Interface - Optical or Copper	Virtex-6

Product Focus

Model 71720

Triple 200 MHz, 16-bit A/D, Upconverter with Dual 800 MHz, 16-bit D/A, Virtex-7 FPGA - XMC

General Information

Model 71720 is a member of the Onyx family of high-performance XMC modules based on the Xilinx Virtex-7 FPGA. A multi-channel, high-speed data converter, it is suitable for connection to HF or IF ports of a communications or radar system. Its built-in data capture and playback features offer an ideal turnkey solution. It includes three A/Ds, two D/As and four banks of memory.

The Onyx Architecture

Based on the proven design of the Pentek Cobalt Family, Onyx raises the processing performance with the new flagship family of Virtex-7 FPGAs from Xilinx. As the central feature of the board architecture, the FPGA has access to all data and control paths, enabling factory-installed functions including data multiplexing, channel selection, data packing, gating, triggering and memory control. The Onyx Architecture organizes the FPGA as a container for data processing applications where each function exists as an IP (intellectual property) module.

Each member of the Onyx family is delivered with factory-installed applications ideally matched to the board's analog



Model 71720 is also available in OpenVPX, PCI Express, AMC, and CompactPCI formats.

Features

- Supports Xilinx Virtex-7 VXT FPGAs
- GateXpress™ supports dynamic FPGA reconfiguration across PCIe
- Three 200 MHz 16-bit A/Ds
- One digital upconverter
- Two 800 MHz 16-bit D/As
- 4 GB of DDR3 SDRAM
- Sample clock synchronization to an external system reference
- LVPECL clock/sync bus for multimodule synchronization
- PCI Express (Gen. 1, 2 and 3) interface, up to x8
- Optional LVDS connections to the Virtex-7 FPGA for custom I/O

interfaces. The 71720 factory-installed functions include three A/D acquisition and a D/A waveform playback IP modules for simplifying data capture and data transfer.

The architecture includes **GateXpress**, a sophisticated FPGA-PCIe configuration manager for loading and reloading the FPGA. At power up, GateXpress immediately presents a PCIe target for the host computer to discover, effectively giving the FPGA time to load from FLASH. This is especially important for larger FPGAs where the loading times

can exceed the PCIe discovery window, typically 100 msec on most PCs.

A/D Converters

The front end accepts three full-scale analog HF or IF inputs on front panel SSMC connectors at +8 dBm into 50 ohms with transformer coupling into three Texas Instruments ADS5485 200 MHz, 16-bit A/D converters.

The digital outputs are delivered into the Virtex-7 FPGA for signal processing, data capture or for routing to other module resources.

Digital Upconverter and D/As

A TI DAC5688 DUC (digital upconverter) and D/A accepts a baseband real or complex data stream from the FPGA and provides that input to the upconvert, interpolate, and dual D/A stages.

Memory Resources

The 71720 architecture supports four independent DDR3 SDRAM memory banks. Each bank is 1 GB deep and is an integral part of the module's DMA capabilities, providing FIFO memory space for creating DMA packets. Built-in memory functions include multichannel A/D data capture, tagging and streaming.

For more information and a price quotation on the Model 71720, go to:

pentek.com/go/pipe71720

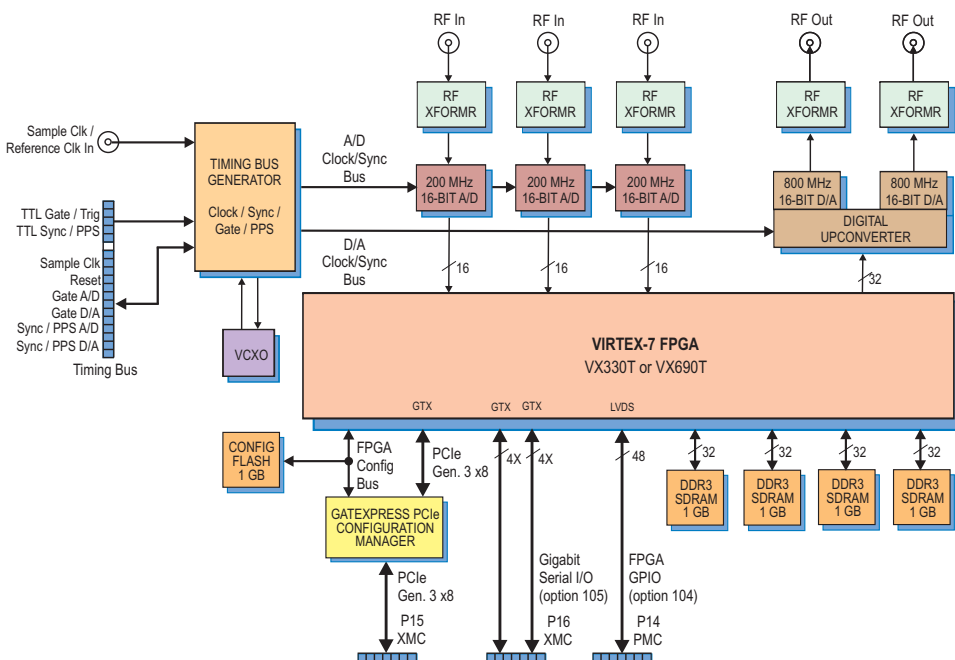

Product Focus

Model 8111

Bandit Analog Modular RF Slot Receivers

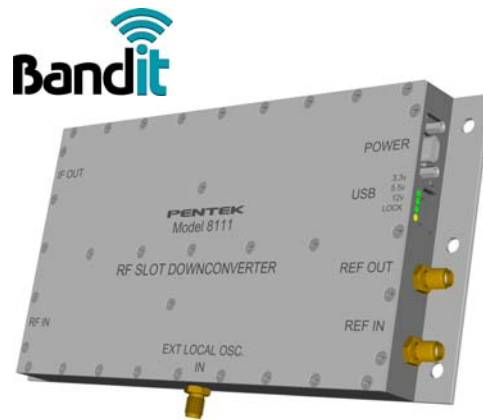

General Information

The Bandit™ Model 8111 includes a series of high-performance, stand-alone RF receiver modules. Packaged in a small, shielded enclosure with connectors for easy integration into RF systems, the modules offer programmable gain, high dynamic range and a low noise figure. With input options to cover specific frequency bands of the RF spectrum, and an IF output optimized for A/D converters, the 8111 is an ideal solution for amplifying and downconverting antenna signals for communications, radar and signal intelligence systems.

Programmable Input Level

The 8111 accepts RF signals on a front panel SMA connector. An LNA (Low Noise-figure Amplifier) is provided along with two programmable attenuators allowing down-conversion of input signals ranging from -60 dBm to -20 dBm in steps of 0.5 dB. Higher level signals can be attenuated prior to input.

Preselector Options

Seven different input-frequency band options are offered, each tunable across a 400 MHz band, with an overlap of 100 MHz between adjacent bands. As a group, these seven options accommodate RF input signals from 800 MHz to 3000 MHz as follows:

Option	Frequency Band
001	800-1200 MHz
002	1100-1500 MHz
003	1400-1800 MHz
004	1700-2100 MHz
005	2000-2400 MHz
006	2300-2700 MHz
007	2600-3000 MHz

Tuning Accuracy

The 8111 uses a low-noise, on-board frequency synthesizer as the LO (Local Oscillator). Locked to an external input reference for accuracy, its frequency is programmable across the 400 MHz band with a tuning resolution of 1 MHz. Alternatively, an external LO input signal can be accepted on a front panel connector and used instead of the on-board frequency synthesizer.

Features

- Accepts RF signals from 800 MHz to 3 GHz in seven different models
- Accepts RF input levels from -60 dBm to -20 dBm
- 225 MHz IF output with 80 MHz output bandwidth
- Internal OXCO or external 10 MHz frequency reference



On-board Reference Clock

The 8111 includes an on-board 10 MHz crystal oscillator which can be used as the reference to lock the internal LO.

This reference is an OCXO (Oven Controlled Crystal Oscillator), which provides an exceptionally precise frequency standard with excellent phase noise characteristics.

Wide IF Output

An 80 MHz-wide IF output is provided at a 225 MHz center frequency. This output is suitable for A/D conversion using Pentek high-performance signal acquisition products, such as those in the Cobalt and Onyx families.

For more information and a price quotation on the Model 8111, go to:

pentek.com/go/pipe8111 □

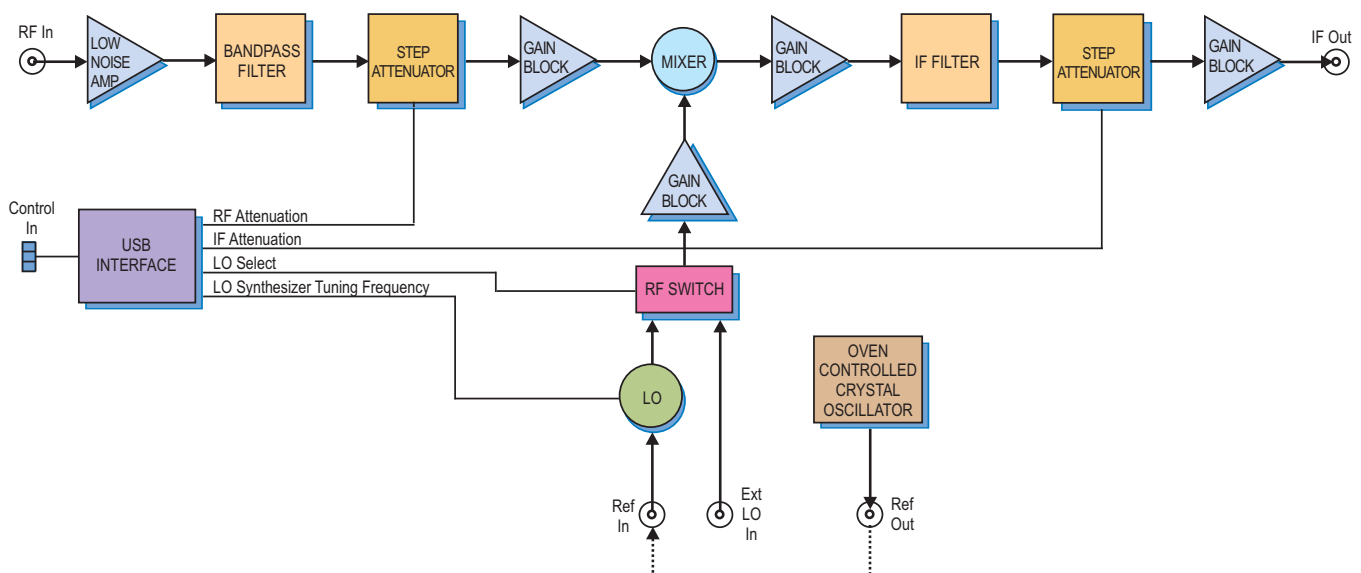

Product Focus

Model 8266

General Information

The Model 8266 is a fully-integrated PC development system for Pentek 786xx Cobalt Virtex-6 and 787xx Onyx Virtex-7 PCI Express software radio, data acquisition, and I/O boards. It was created to save engineers and system integrators the time and expense associated with building and testing a development system that ensures optimum performance of Pentek boards.

A fully-integrated system-level solution, the 8266 provides the user with a streamlined out-of-the-box experience. It comes preconfigured with Pentek hardware, drivers and software examples installed and tested, so that development engineers can run example applications out of the box.

ReadyFlow Software

Pentek ReadyFlow drivers and board support libraries are preinstalled and tested with the 8266. ReadyFlow includes example applications with full source code, a command line interface for custom control over hardware, and Pentek's Signal Analyzer, a full-featured analysis tool that continuously

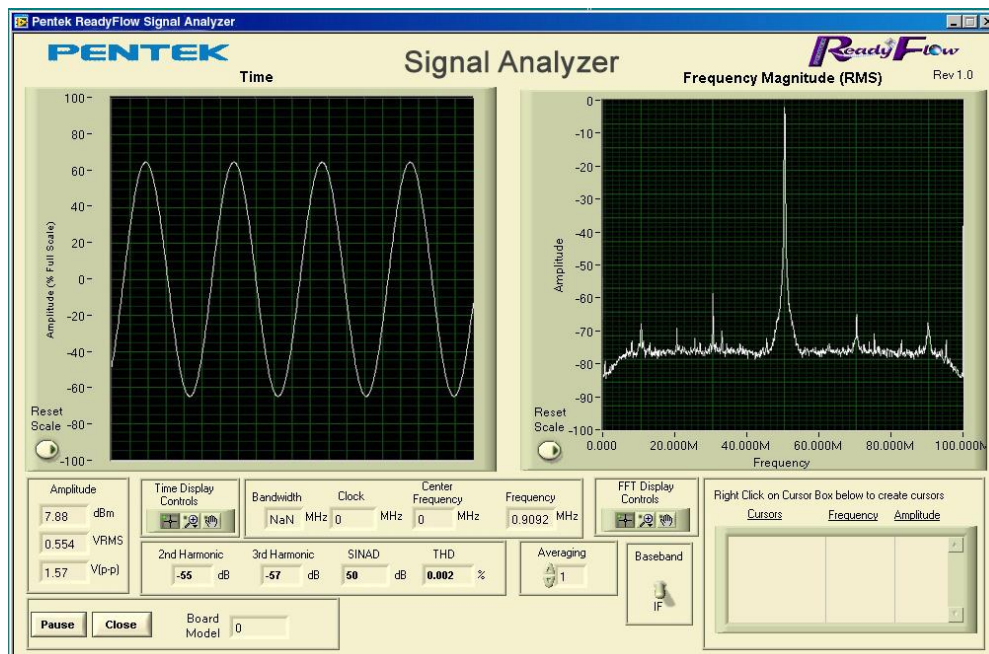

PC Development System for PCIe Cobalt and Onyx Boards

Features

- 4U 19-inch rackmount PC server chassis, 21-inch deep
- 64-bit Windows® 7 Professional or Linux® workstation
- Intel® Core™ i7 3.6 GHz processor
- 8 GB DDR3 SDRAM
- ReadyFlow® drivers and board support libraries installed
- Out-of-the-box test examples
- All I/O cables included



displays live signals in both time and frequency domains.

System Implementation

Built on a professional 4U rackmount workstation, the 8266 is equipped with the latest Intel processor, DDR3 SDRAM and a high-performance motherboard. These features accelerate application code development and provide unhindered access to the high-bandwidth data available with Cobalt and Onyx analog and digital interfaces. The 8266 can be configured with 64-bit Windows or Linux operating systems.

The 8266 uses a 19" 4U rackmount chassis that is 21" deep. Enhanced forced-air ventilation assures adequate cooling for Pentek Cobalt and Onyx boards.

The chassis is designed to draw cool air from the front and push warm air out the back. A 1000-W, 80+ Gold Power Supply guarantees more than enough power for additional boards.

PCIe Slots

The 8266 has a total of six PCIe slots:

Slot	Description
1	PCIe 3.0, x16 single or dual x8/x8
2	PCIe 3.0, x16 or x8
3	PCIe 2.0, x16 or x4
4	PCIe 3.0, x16 single or dual x8/x8
5	PCIe 2.0, x16 or x4
6	PCIe 3.0, x16 or x8

Pentek installs a video card in addition to the I/O boards in the available slots. The remaining slots are available to the user.

Options

With options for high-end multicore CPUs and extended memory, the 8266 supports applications that require additional horsepower.

All necessary analog I/O cables are installed and tested, providing SMA connectivity for all analog I/O lines.

For more information and a price quotation on the Model 8266 go to:

pentek.com/go/pipe8266 □

Product Focus

Model RTR 2727

General Information

The Talon® RTR 2727 is a turnkey, multi-band recording and playback system that allows the user to record and reproduce high-bandwidth signals with a lightweight, portable and rugged package. The RTR 2727 provides aggregate recording rates of up to 2.0 GB/sec in a two-channel system and is ideal for the user who requires both portability and solid performance in a compact recording system.

The RTR 2727 is supplied in a small footprint portable package measuring only 16.9" W x 9.5" D x 13.4" H and weighing just 30 pounds. With measurements similar to a small briefcase, this portable workstation includes an Intel Core i7 processor a high-resolution 17" LCD monitor, and a high-performance SATA RAID controller.

At the heart of the RTR 2727 are Pentek Cobalt Series Virtex-6 software radio boards featuring A/D and D/A converters, DDCs, DUCs, and complementary FPGA IP cores. This architecture allows the system engineer to take full advantage of the latest technology in a turnkey system.

Optional GPS time and position stamping allows the user to record this critical signal information.

Two-Channel RF/IF 500 MS/sec Rugged Portable Recorder

Features

- Portable system measuring 16.9" W x 9.5" D x 13.4" H
- Lightweight: approximately 30 pounds
- Shock- and vibration-resistant SSDs (Solid State Drives) perform well in vehicles, ships and aircraft
- Recording & playback of IF signals up to 700 MHz
- Signal bandwidths to 200 MHz
- 500 MHz 12-bit or 400 MHz 14-bit A/Ds
- 800 MHz 16-bit D/A
- SFDR > 70 dBFS
- Real-time aggregate recording rates up to 2.0 GB/sec
- Up to of 3.8 TB storage with hot-swappable SSD drives
- NTFS file format
- SystemFlow® GUI with Signal Viewer analysis tool
- Optional GPS time and position stamping
- High-performance Windows workstation



SystemFlow Software

Included in this system is the Pentek SystemFlow recording software. SystemFlow features a Windows-based GUI that provides a simple means to configure and control the system.

Custom configurations can be stored as profiles and later loaded when needed, allowing the user to select preconfigured settings with a single click.

SystemFlow also includes signal viewing and analysis tools, that allow the user to

monitor the signal prior to, during, and after a recording session. These tools include a virtual oscilloscope and a virtual spectrum analyzer.

Built on a Windows 7 Professional workstation, the RTR 2727 allows the user to install post processing and analysis tools to operate on the recorded data. The RTR 2727 records data in the native NTFS file system, providing immediate access to the recorded data.

Data can be off-loaded through two 1 Gb Ethernet ports, eight USB 2.0 ports or two eSATA ports. Additionally, data can be copied to optical disk, using the 8X double layer DVD±R/RW drive.

Rugged Architecture

The RTR 2727 is configured in a portable, lightweight chassis with eight hot-swap SSDs, front panel USB ports and I/O connections on the side panel. It is built on an extremely rugged, 100% aluminum alloy unit, reinforced with shock absorbing rubber corners and impact-resistant protective glass. Using shock- and vibration-resistant SSDs, the RTR 2727 is designed to operate reliably as a portable field instrument. The eight SSDs provide storage capacities of up to 3.8 TB.

For more information and a price quotation on the Model RTR 2727, go to:

pentek.com/go/pipe2727 □

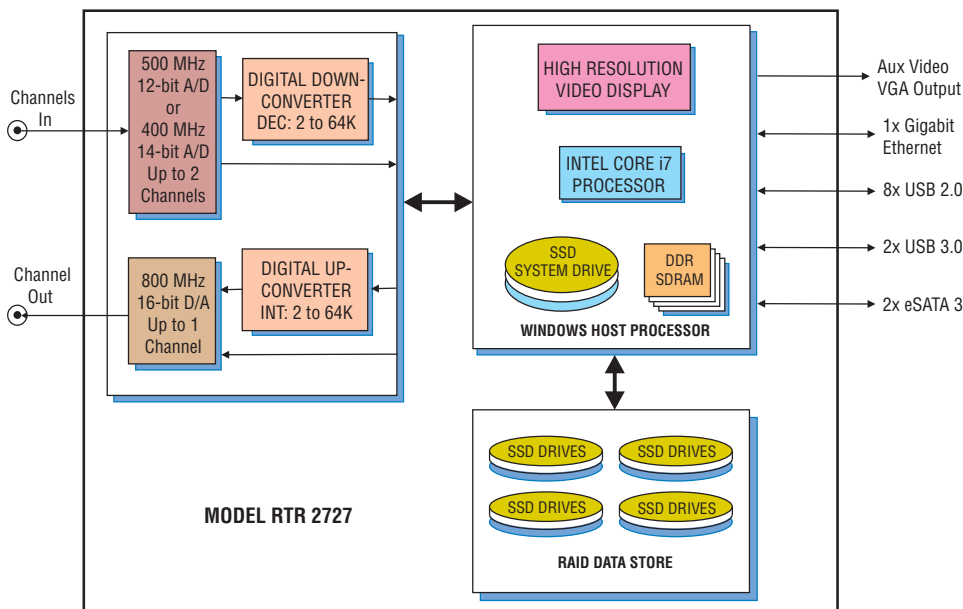

Product Focus

Model RTX 2786

Four-Channel RF/IF 200 MS/sec Extreme 3U VPX Recorder

General Information

The Talon RTX 2786 is a turnkey, RF/IF signal recorder designed to operate under extreme environmental conditions. Housed in a ½ ATR chassis, the RTX 2786 leverages Pentek's 3U VPX SDR modules to provide a rugged recording system with up to four 16-bit, 200 MHz A/D converters with built-in digital downconversion capabilities.

Optionally, the RTX 2786 provides one 800 MHz, 16-bit D/A converter with a digital upconverter for signal playback or waveform generation. As shown in the block diagram below, the maximum number of record channels with this option is three.

The RTX 2786 can record and play back analog signals with bandwidths ranging from a few kHz up to 80 MHz, either as baseband signals or as IF signals with center frequencies tunable across a 700 MHz range.

The RTX 2786 uses conduction cooling to draw heat from the system components allowing it to operate in reduced air environments. It includes 1.92 TB of solid-state data storage, that allows it to operate with no degradation under conditions of extreme shock and vibration. The system is hermetically sealed and provides five D38999 connectors for power and I/O. Four SMA connectors are used for analog I/O.

Features

- Multiband recording and playback system
- ½ ATR 3U VPX chassis
- Designed to MIL-STD-704F, 810F and 461F
- Windows 7 Professional workstation with high performance Intel Core i7 processor
- 200 MHz 16-bit A/Ds for recording up to four channels
- 800 MHz 16-bit D/A for playback of one channel
- 80 MHz max. record and playback signal bandwidths
- DDC decimation and DUC interpolation ranges from 2 to 65,536
- Capable of record/playback of IF frequencies to 700 MHz
- Real-time aggregate recording rates up to 500 MB/sec
- 1.92 TB of storage to NTFS RAID disk array
- RAID levels of 0, 1, 5 and 6
- SystemFlow GUI with signal viewer analysis tool which includes a virtual oscilloscope and spectrum analyzer



The recorder includes a graphical user interface for quick and simple out-of-the-box operation. It also includes a user API (Application Programming Interface) to easily integrate the system into the user's application.

SystemFlow Software

The RTX 2786 includes Pentek's SystemFlow Recording Software. SystemFlow features a Windows-based GUI that provides a simple means to configure and control the system.

SystemFlow also includes signal viewing and analysis tools, that allow the user to monitor the signal prior to, during, and after a recording session. These tools include a virtual oscilloscope and a virtual spectrum analyzer.

The user API allows users to integrate the recorder as a subsystem of a larger system. The API is provided as a C-callable library and allows for the recorder to be controlled over Ethernet, thus providing the ability to remotely control the recorder from a custom interface.

Built on a Windows 7 Professional workstation, the RTX 2786 allows the user to install post-processing and analysis tools on the system itself to operate on the recorded data. The RTX 2786 records data to the Windows' native NTFS file system, providing immediate access to all recorded data. Data can be off-loaded via dual gigabit Ethernet ports or four USB 2.0 ports.

Four built-in solid-state drives provide reliable, high-speed storage with a total capacity of 1.92 TB.

For more information and a price quotation on the Model RTX 2786, go to:

pentek.com/go/pipe2786 □

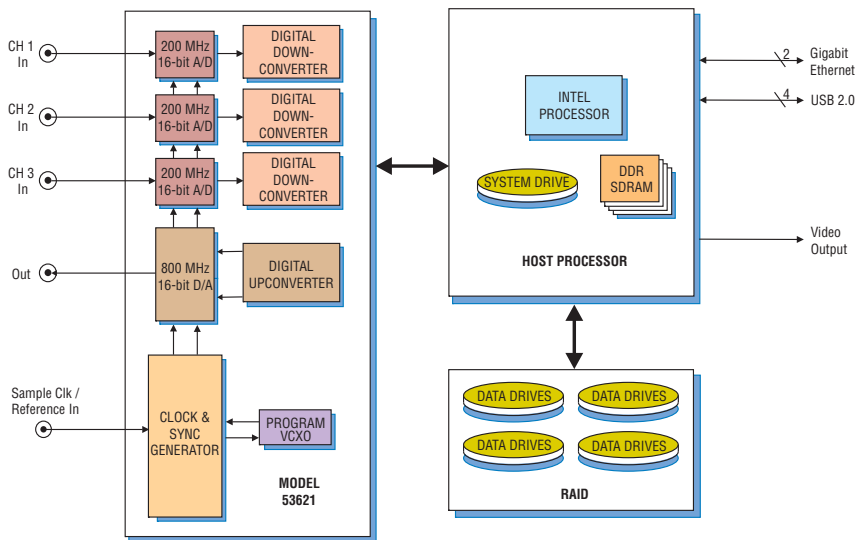

MODEL RTX 2786

Three Record Channels and One Playback Channel.



Last Call for Bundle Offer!
- Save \$2,000 -
Expires July 31!



Cobalt or Onyx Offer Includes:

- Cobalt Virtex-6 or Onyx Virtex-7 boards available in XMC, PCI Express, OpenVPX, AMC and cPCI formats
- ReadyFlow board support libraries for Windows or Linux
- Time- and frequency-domain signal analyzer utility
- Command-line interface
- Operating manuals and full documentation
- Complete cable kit
- Lifetime product support
- Online technical resources with automatic alerts for updates and new releases

It's Up to You!

Simply Choose:

- Any Cobalt or Onyx product
- Form factor: XMC, PCIe, OpenVPX, AMC, cPCI, or rugged
- Board support package OS: Windows or Linux



Product Features:

- A/D sampling rates from 10 MHz to 3.6 GHz
- D/A sampling rates from 10 MHz to 1.25 GHz
- Multiboard synchronization
- ReadyFlow board support libraries
- GateFlow® FPGA Design Kit and installed IP cores
- Complete solutions for wireless communications, radar, SIGINT, and beamforming

Partial List of These Products:

- [Model 71630 - XMC](#)
Single 1 GHz A/D and 1 GHz D/A
- [Model 53650 - OpenVPX](#)
Dual 500 MHz A/D, DUC, and Dual 800 MHz D/A
- [Model 78720 - PCIe](#)
Triple 200 MHz A/D, DUC, and Dual 800 MHz D/A
- [Model 71621 - XMC](#)
Triple 200 MHz A/D, DDC, DUC, and Dual 800 MHz D/A
- [Model 78760 - PCIe](#)
Quad 200 MHz 16-bit A/D, Virtex-7
- [Model 53661 - OpenVPX](#)
Quad 200 MHz 16-bit A/D
Quad DDC with beamforming IP
- [Model 56662 - AMC](#)
Quad 200 MHz 16-bit A/D with 32 DDC channels
- [Model 74690 - 6U cPCI](#)
Dual L-Band (925–2175 MHz)
Tuners with Quad 200 MHz A/D

For a full list of these products [Click here](#)

Video Spotlight



View High-Speed Real-Time Recording System for Harsh Environments & UAV Applications



Talon RTR 2746 Rugged
200 MHz High-Speed Recording and Playback System

Video Spotlight



View **SystemFlow Software** for Talon Recorders

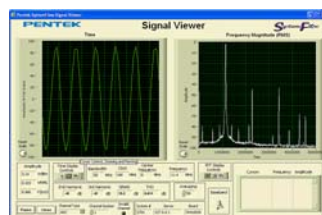

Topics include: API, GUI, Signal Viewer, Signal Analyzer, Function Libraries & the NTFS file management system

Video Spotlight



View Virtex-6 Board Ideal for Multichannel Waveform Generation



Cobalt Model 78670
Quad 1.25 GHz, 16-bit D/A