

Pentek, Inc.

One Park Way, Upper Saddle River, NJ 07458
Tel: (201) 818-5900 • Fax: (201) 818-5904
email: pipeline@pentek.com
http://www.pentek.com

© 2003 Pentek, Inc. Newsletter Editor: TNT Resources
Trademarks are properties of their respective owners.
Specifications are subject to change without notice.

MITRE Designs an Adaptive Spectrum Radio Platform

The MITRE Corporation is a not-for-profit organization chartered to work in the public interest.

It operates as a strategic partner with its sponsoring government agencies and addresses issues of national importance. Through the combination of systems engineering and information technology, it develops innovative solutions.

MITRE's work is focused within three federally funded research and development centers: one performs systems engineering and integration work for the Department of Defense; the second performs essential engineering activities for the Federal Aviation Administration and other civil aviation authorities to modernize and harmonize the world's air traffic management systems; the third provides strategic, technical and program management advice to the Internal Revenue Service and other government agencies.

One of MITRE's recent projects centers around improving the spectrum utilization in RF communications.

Dynamic Spectrum Access

New and potentially more beneficial ways of managing and allocating the electromagnetic spectrum are now possible due to advances in technology and a receptive environment within regulatory agencies such as the FCC. Advancing technologies provide the key to dynamically adapt and access the spectrum. In order to demonstrate the feasibility of these new technologies that enable dynamic spectrum access, The MITRE Corporation has developed a feasibility radio platform that demonstrates the principles for dynamically accessing the spectrum, as it adapts its transmit waveform to exploit spectrum gaps in frequency and time.

Advances in digital signal processing hardware allow radios to dynamically change the transmission parameters,

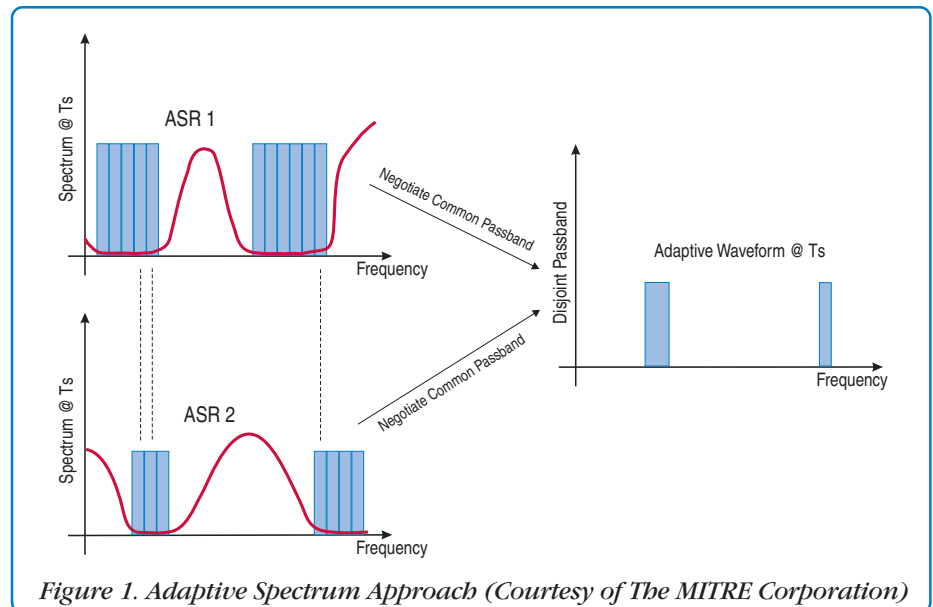

such as data rates, coding rates, and even the modulation order. DSP-based radios typically referred to as software radios or software-defined radios (SDR), increasingly provide the platform for these dynamic radio systems.

Forms of adaptive spectrum access have been implemented. A rudimentary form of such access is the selection of a frequency channel based on measurements of activity. More advanced implementations include the methods for changing data rate, code rate, and modulation order implemented by second (2G) and third generation (3G) mobile standards. This type of adaptability is suitable for packet data and situations with slow variations in fading and distance loss over the cell coverage area.

MITRE has developed an Adaptive Spectrum Radio (ASR) testbed. Its architecture supports SDR development using ASICs, DSPs, and FPGAs with MITRE software.

One key benefit for adaptive spectrum access is the potential to improve the efficiency in spectrum use. By adjusting

transmissions, adaptive systems can utilize unused frequencies even if they vary over time. Furthermore, adaptive systems can maintain quality of service in a changing environment while they also adjust emissions to reduce interference to other systems.

Overview of MITRE's Adaptive Spectrum Radio

MITRE developed an adaptive spectrum approach to operate in the midst of a FDM (frequency division multiplexing) communication system. Figure 1 depicts an adaptive waveform transmitting data over the common unoccupied frequencies. Such a waveform requires non-contiguous modulated carriers with very sharp rolloffs outside their passbands. One way to achieve this is to sum a series of individually modulated and filtered carriers to fill each unoccupied gap in the spectrum. However, a more integrated approach improves computational efficiency.

MITRE's work successfully implemented an adaptive waveform ➤

MITRE Designs an Adaptive Spectrum Radio Platform

[Continued from page 1]

synthesis using a signal similar to orthogonal frequency division multiplexing (OFDM). [See <http://www.pentek.com/whatsnew>]. The core IFFT transform provides a potential advantage since, as the spectrum occupancy estimator for a FDM system uses the FFT, it makes it possible to integrate the sensing and demodulation process.

Testbed Architecture

The testbed demonstrates the feasibility of the adaptive spectrum radio by providing these basic capabilities:

- 1 Periodic estimation of channel occupancy rate
- 2 Periodic adaptation of a time-limited waveform in response to occupancy rate estimates
- 3 Periodic “joint occupancy vector” negotiation with subsequent burst data transfer
- 4 Measurement of impairments to primary users

The testbed is a software defined radio platform and uses commercial off-the-shelf (COTS) hardware that includes ASICs, FPGAs and DSPs. While significant processing takes place inside the DSPs, high speed processing within the ASICs and FPGAs allows the testbed to demonstrate the adaptive spectrum process over a much wider bandwidth than would be possible without them.

Figure 2 shows the hardware setup of the testbed. It includes two small VME chassis, a host computer and test signal generators. The VME hardware in each chassis includes a Pentek Model 6231 16-channel digital down-converter VIM-2 module with two A/Ds and FPGA, and a Pentek Model 6229 dual digital upconverter VIM-2 module with D/As. The two VIMs are mounted on a Pentek Model 4291 Quad C6701 floating-point processor VME board. An Ethernet adapter board is also included for communicating with the host computer that runs Pentek SwiftNet networking protocol, Pentek ReadyFlow board support libraries, and TI Code Composer Studio.

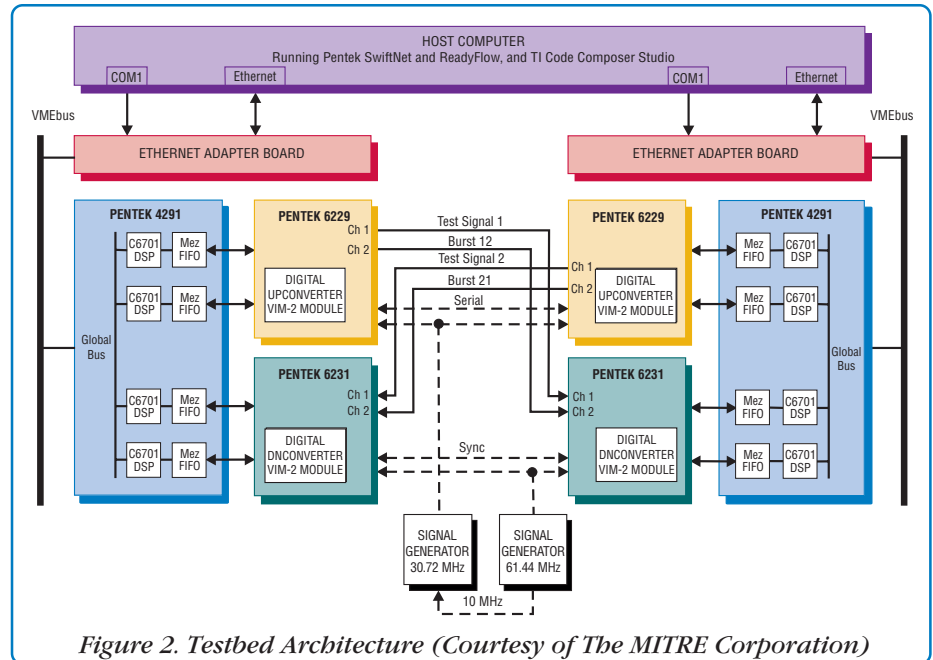

Figure 2. Testbed Architecture (Courtesy of The MITRE Corporation)

Signal Processing

MITRE has demonstrated capabilities 1 and 2 mentioned previously by implementing an Adaptive FDM Burst Modulator. Figure 3 shows how the signal processing maps into the hardware.

The Test Signal Generator cycles through 15 different “spectrum occupancy” scenarios to create a test signal for the Adaptive FDM Burst Modulator. Each scenario has a different spectrum occupancy state defined by the on/off state of 256 modulated carriers.

The Channel Occupancy Estimator periodically produces an “occupancy

vector” (OV) that tells the burst modulator what waveform to synthesize. The OV tracks the test signal so that the modulator avoids using spectrum occupied by the primary user.

The A/D periodically captures a wideband block of input samples and passes them through eight digital down-converter channels. The downsampled data are transformed from the time domain into estimates of power spectral density (PSD) through a FFT performed in the DSP. To discriminate between high- and low-power signals, a threshold test converts the PSD data into binary variables representing the results of occupancy/no

occupancy decisions. The data is then merged into an OV containing 256 binary decision variables, one variable for each of the carriers in the test signal.

By treating certain unoccupied channels as occupied, the Adaptive Burst Modulator imposes rolloff limitations by

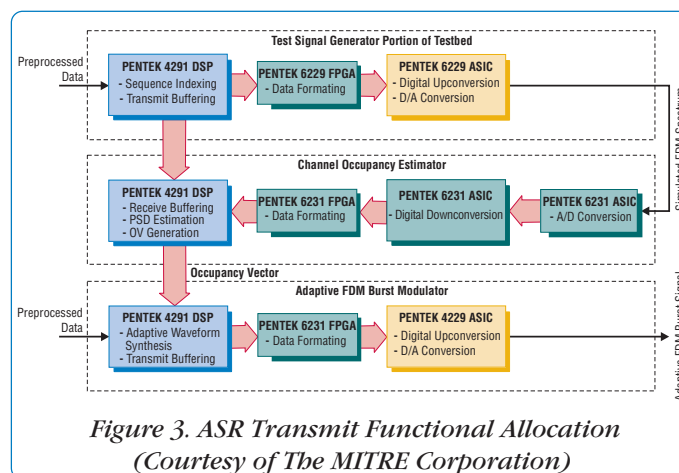

Figure 3. ASR Transmit Functional Allocation (Courtesy of The MITRE Corporation)

32-Channel A/D Converter VME Board with FPDP Output

[From page 4]

A programmable divider can be used to divide the internal or external system clock by a factor of 1, 2, 4, 8, 16, 32, 64 or 128.

Synchronization

The front panel sync input signal allows synchronization of up to eight 6802 boards. In addition, the front panel connector provides trigger signal I/O for data collection in the on-board FIFO memory.

FPDP Output

The number of active A/D channels can be selected from 1 to 32 in steps of 1. Data samples from all selected channels are then interleaved and stored in a 32-bit wide FIFO memory as either one 24-bit sample or two packed 16-bit samples.

The FIFO delivers samples from all selected channels to the FPDP output

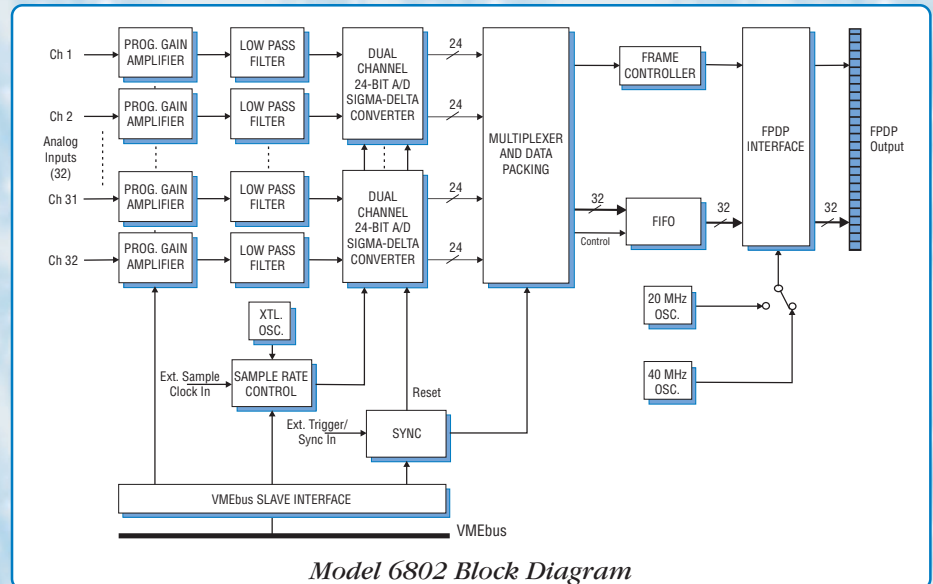

Model 6802 Block Diagram

using 40 MHz PECL or 20 MHz TTL strobes.

Model 6802 is ideal for sonar and acoustical applications. For more information and specs, visit our website at:

www.pentek.com/go/pipe6802, or call us at 201-818-5900 to discuss your data acquisition and signal processing requirements with one of our knowledgeable sales engineers. □

creating guard bands between its populated and unpopulated carriers. In essence, the channel occupancy estimator alters the OV to avoid primary user interference by accommodating filtering limitations within the burst modulator.

The channel occupancy estimator periodically interrupts the burst modulator with an updated OV. After each interrupt, the burst modulator responds by synthesizing a waveform tailored to the OV. All operations are complex and prior to performing a complex IFFT, pulse-shaped data fills its frequency bins. Following the transformation of the data samples from the frequency to the time domain, upsampling through the upconverter followed by the D/A conversion, completes a single burst cycle within the burst modulator processing.

Future Work

MITRE has already started work towards demonstrating capabilities ③ and ④. For more information, contact pweed@mitre.org. □



Evaluate New FPGA IP Core Libraries Online!

- Highly-optimized FFT engines and wideband digital downconverters
- Faster, higher-performance alternatives to ASICs and DSPs
- 10x FFT speed improvement handles more than 500 MHz real-time data
- Wideband receivers deliver increased speed, resolution and accuracy
- Features are targeted for signal intelligence and radar applications

Pentek has just introduced five highly optimized GateFlow™ IP Core Libraries that are the fastest in their class from any vendor. The Model 4954 GateFlow IP Cores are set apart by their speed, accuracy and performance, yielding tangible savings in system costs and development time. By encapsulating numerous man-months of optimization, enhancement, testing and documentation, each core offers a

highly reliable, fully characterized, off-the-shelf computational engine, all ready for deployment in high-performance FPGA-based systems.

FREE Evaluation!

The GateFlow IP Core Library is Pentek's latest commitment to help customers benefit from the Xilinx industry-leading FPGA devices. It's easy to 'test drive' these new cores from Pentek's website. With simulation tools, you can verify how these cores will perform in your final system, including resource utilization, operational characteristics and signal quality.

For additional information or to download the cores for a FREE evaluation, go to www.pentek.com/go/pipegfp. For the latest pricing and availability information, contact Pentek sales at 201-818-5900. □

Product Focus

Model 6802



Model 6802 32-channel A/D converter delivers output samples through a front panel FPDP connector.

32-Channel A/D Converter VME Board with FPDP Output Model 6802 Features 24-bit A/Ds and 216 kHz maximum sampling

Features

- 32 sigma-delta A/D channels
- 24-bit accuracy, SNR > 90 dB
- Differential inputs, ± 5.0 V full scale
- Instrumentation amplifiers with programmable gain of 1, 10 or 100
- 100 kHz anti-aliasing filters

Model 6802 is a high-performance 32-channel A/D converter board capable of sampling rates to 218 kHz. A single-slot VMEbus board, the 6802 includes signal conditioning, anti-alias filtering and clock generation circuitry. Output samples are delivered to a FPDP connector.

Signal Conditioning

The Model 6802 accepts 32 differential analog inputs with 16 channels on each of two front panel multipin connectors compatible with discrete wire termination.

Programmable-gain instrumentation amplifiers deliver each signal to a single-pole 100 kHz low pass anti-aliasing filter.

A/D Conversion

Sixteen monolithic, dual-channel sigma-delta A/Ds provide 32 channels of A/D conversion. The A/Ds feature 24-bit resolution at sampling rates ranging from 1 kHz to 216 kHz. They offer excellent channel-to-channel matching and linear phase response.

Sampling Control

The A/Ds utilize a high-speed system clock capable of 64x, 128x or 256x oversampling. The clock is sourced by an internal crystal oscillator or by an external clock supplied through a front panel DB9 connector. The internal oscillator can be replaced for custom sampling frequencies. ➤