

New!

# Models 57661 & 58661

# 4- or 8-Channel 200 MHz A/D with DDCs and Virtex-6 FPGA - 6U OpenVPX



Model 58661



## General Information

Models 57661 and 58661 are members of the Cobalt® family of high-performance 6U OpenVPX boards based on the Xilinx Virtex-6 FPGA. They consist of one or two Model 71661 XMC modules mounted on a VPX carrier board.

Model 57661 is a 6U board with one Model 71661 module while the Model 58661 is a 6U board with two XMC modules rather than one.

These models include four or eight A/Ds, four or eight multiband DDCs, one or two programmable beamformers, and four or eight banks of memory.

## The Cobalt Architecture

The Pentek Cobalt Architecture features a Virtex-6 FPGA. All of the board's data and control paths are accessible by the FPGA, enabling factory-installed functions including data multiplexing, channel selection, data packing, gating, triggering and memory control. The Cobalt Architecture organizes the FPGA as a container for data processing applications where each function exists as an intellectual property (IP) module.

Each member of the Cobalt family is delivered with factory-installed applications ideally matched to the board's analog interfaces. The factory-installed functions of these models include four or eight A/D acquisition IP modules. Each of the acquisition IP modules contains a powerful, programmable DDC IP core. IP modules for either DDR3 or QDRII+ memories,

controllers for all data clocking and synchronization functions, test signal generators, programmable beamforming IP cores, an Aurora gigabit serial interface, and a PCIe interface complete the factory-installed functions and enable these models to operate as complete turnkey solutions without the need to develop any FPGA IP.

## Extendable IP Design

For applications that require specialized function, users can install their own custom IP for data processing. Pentek GateFlow FPGA Design Kits include all of the factory installed modules as documented source code. Developers can integrate their own IP with the Pentek factory-installed functions or use the GateFlow kit to completely replace the Pentek IP with their own.

## Xilinx Virtex-6 FPGA

The Virtex-6 FPGA site can be populated with two different FPGAs to match the specific requirements of the processing task. Supported FPGAs include: LX240T or SX315T. The SXT part features 1344 DSP48E slices and is ideal for modulation/demodulation, encoding/decoding, encryption/decryption, and channelization of the signals between transmission and reception. For applications not requiring large DSP resources, the lower-cost LXT FPGA can be installed.

Option -104 provides 20 LVDS pairs between the FPGA and the VPX P3 connector, Model 57661; P3 and P5, Model 58661. ▶

## Features

- Supports Xilinx Virtex-6 LXT and SXT FPGAs
- Four or eight 200 MHz 16-bit A/Ds
- Four or eight multiband DDCs (digital downconverters)
- One or two multiboard programmable beamformers
- Up to 2 or 4 GB of DDR3 SDRAM; or: 32 MB or 64MB of QDRII+ SRAM
- PCI Express (Gen. 1 & 2) interface up to x8
- Sample clock synchronization to an external system reference
- LVPECL clock/sync bus for multiboard synchronization
- Optional LVDS connections to the Virtex-6 FPGA for custom I/O
- Ruggedized and conduction-cooled versions available

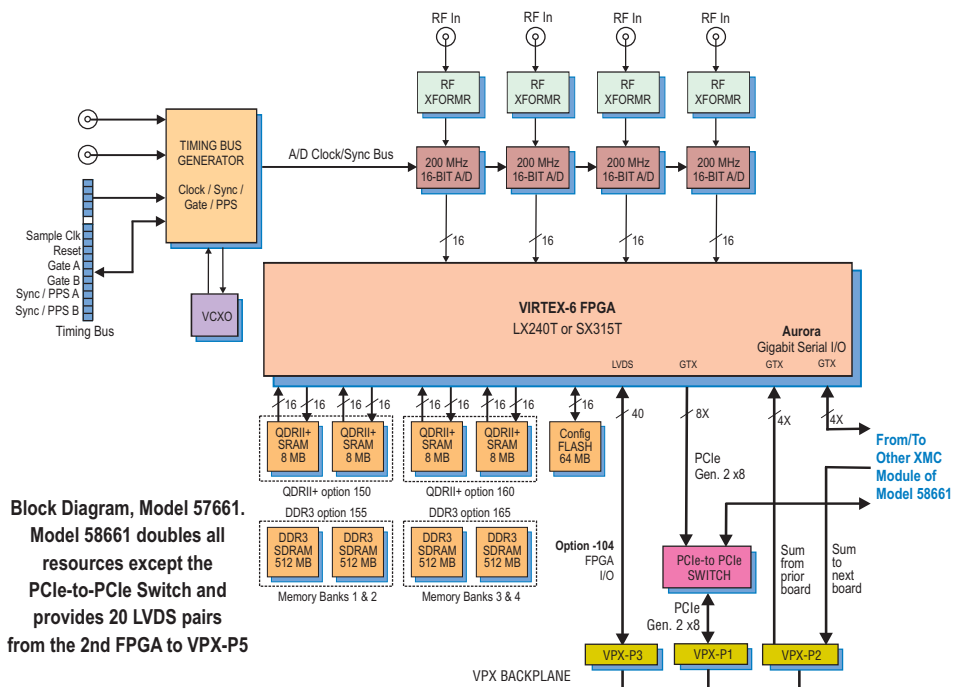

**A/D Acquisition IP Modules**

These models feature four or eight A/D Acquisition IP Modules for easily capturing and moving data. Each IP module can receive data from any of the four A/Ds or a test signal generator

Each IP module has an associated memory bank for buffering data in FIFO mode or for storing data in transient capture mode. All memory banks are supported with DMA engines for easily moving A/D data through the PCIe interface. These powerful linked-list DMA engines are capable of a unique Acquisition Gate Driven mode. In this mode, the length of a transfer performed by a link definition need not be known prior to data acquisition; rather, it is governed by the length of the acquisition gate. This is extremely useful in applications where an external gate drives acquisition and the exact length of that gate is not known or is likely to vary.

For each transfer, the DMA engine can automatically construct metadata packets containing A/D channel ID, a sample-accurate time stamp and data length information. These actions simplify the host processor's job of identifying and executing on the data.

**DDC IP Cores**

Within each A/D Acquisition IP Module is a powerful DDC IP core. Because of the flexible input routing of the A/D Acquisition IP Modules, many different configurations can be achieved including one A/D driving all four DDCs or each of the four A/Ds driving its own DDC.

Each DDC has an independent 32-bit tuning frequency setting that ranges from DC to  $f_s$ , where  $f_s$  is the A/D sampling frequency. Each DDC can have its own unique decimation setting, supporting as many as four different output bandwidths for the board. Decimations can be programmed from 2 to 65,536

providing a wide range to satisfy most applications.

The decimating filter for each DDC accepts a unique set of user-supplied 18-bit coefficients. The 80% default filters deliver an output bandwidth of  $0.8 * f_s / N$ , where N is the decimation setting. The rejection of adjacent-band components within the 80% output bandwidth is better than 100 dB. Each DDC delivers a complex output stream consisting of 24-bit I + 24-bit Q or 16-bit I + 16-bit Q samples at a rate of  $f_s / N$ .

**Beamformer IP Cores**

In addition to the DDCs, these models feature one or two complete beamforming subsystems. Each DDC core contains programable I & Q phase and gain adjustments followed by a power meter that continuously measures the individual average power output. The time constant of the averaging interval for each meter is programmable up to 8K samples. The power meters present average power measurements for each DDC core output in easy-to-read registers.

In addition, each DDC core includes a threshold detector to automatically send an interrupt to the processor if the average power level of any DDC core falls below or exceeds a programmable threshold.

A programmable summation block provides summing of any of the four DDC core outputs. An additional programmable gain stage compensates for summation

change bit growth. A power meter and threshold detect block is provided for the summed output. The output is then directed back into the A/D Acquisition IP Module 1 FIFO for reading over the PCIe. For larger systems, multiple 71661's can be chained together via a built-in Xilinx Aurora gigabit serial interface through the P16 XMC connector. This allows summation across channels on multiple boards.

**A/D Converter Stages**

The front end accepts four or eight analog HF or IF inputs on front panel SSMC connectors with transformer coupling into four or eight Texas Instruments ADS5485 200 MHz, 16-bit A/D converters.

The digital outputs are delivered into the Virtex-6 FPGAs for signal processing, data capture and for routing to other board resources.

**Clocking and Synchronization**

An internal timing bus provides all timing and synchronization required by the A/D converters. It includes a clock, two sync and two gate or trigger signals. An on-board clock generator receives an external sample clock from the front panel SSMC connector. This clock can be used directly by the A/D or divided by a built-in clock synthesizer circuit. In an alternate mode, the sample clock can be sourced from an on-board programmable voltage

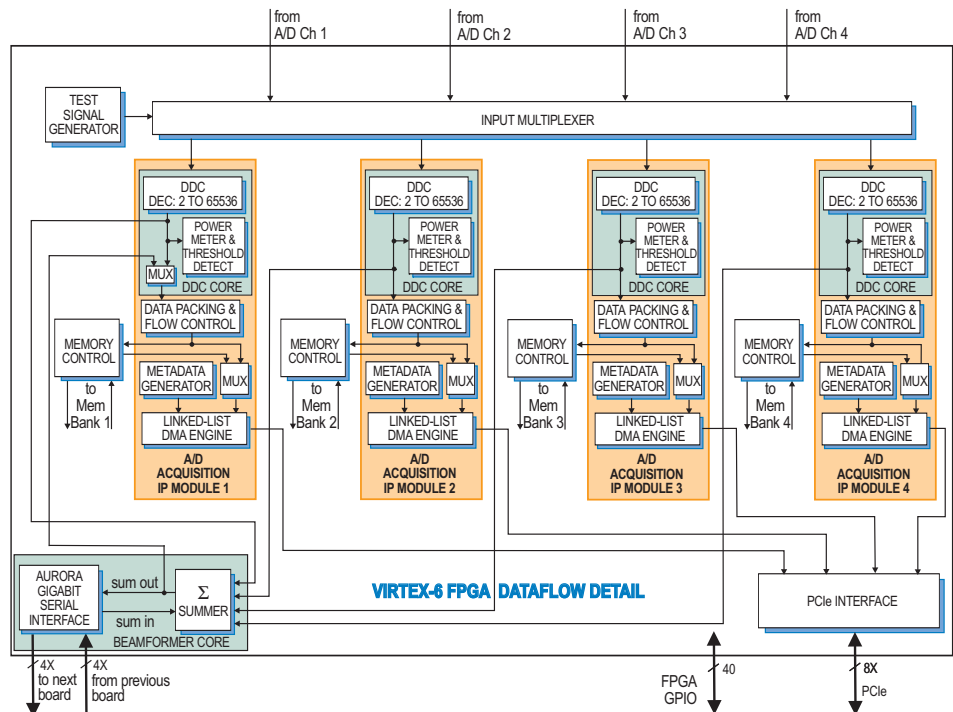

**PCI Express Interface**

These models include an industry-standard interface fully compliant with PCI Express Gen. 1 and 2 bus specifications. Supporting PCIe links up to x8, the interface includes multiple DMA controllers for efficient transfers to and from the board.

**Ordering Information**

Model	Description
57661	4-Channel 200 MHz A/D with DDCs and Virtex-6 FPGA - 6U VPX
58661	8-Channel 200 MHz A/D with DDCs and two Virtex-6 FPGAs - 6U VPX
<b>Options:</b>	
-064	XC6V SX315T
-104	LVDS I/O between the FPGA and P3 connector, Model 57661; P3 and P5 connectors, Model 58661
-150	Two 8 MB QDR II+ SRAM Memory Banks (Banks 1 and 2)
-160	Two 8 MB QDR II+ SRAM Memory Banks (Banks 3 and 4)
-155	Two 512 MB DDR3 SDRAM Memory Banks (Banks 1 and 2)
-165	Two 512 MB DDR3 SDRAM Memory Banks (Banks 3 and 4)

*Contact Pentek for availability of rugged and conduction-cooled versions*

► controlled crystal oscillator. In this mode, the front panel SSMC connector can be used to provide a 10 MHz reference clock for synchronizing the internal oscillator.

A front panel 26-pin LVPECL Clock/Sync connector allows multiple boards to be synchronized. In the slave mode, it accepts LVPECL inputs that drive the clock, sync and gate signals. In the master mode, the LVPECL bus can drive the timing signals for synchronizing multiple boards.

Multiple boards can be driven from the LVPECL bus master, supporting synchronous sampling and sync functions across all connected boards.

**Memory Resources**

The Cobalt architecture supports up to four or eight independent memory banks which can be configured with all QDR II+ SRAM, DDR3 SDRAM, or as combination of two banks of each type of memory.

Each QDR II+ SRAM bank can be up to 8 MB deep and is an integral part of the module's DMA capabilities, providing FIFO memory space for creating DMA packets. For applications requiring deeper memory resources, DDR3 SDRAM banks can each be up to 512 MB deep. Built-in memory functions include multichannel A/D data capture, tagging and streaming.

In addition to the factory-installed functions, custom user-installed IP within the FPGA can take advantage of the memories for many other purposes.

**Specifications**

**Model 57661: 4 A/Ds**

**Model 58660: 8 A/Ds**

**Front Panel Analog Signal Inputs (4 or 8)**

**Input Type:** Transformer-coupled, front panel female SSMC connectors

**Transformer Type:** Coil Craft WBC4-6TLB

**Full Scale Input:** +8 dBm into 50 ohms

**3 dB Passband:** 300 kHz to 700 MHz

**A/D Converters (4 or 8)**

**Type:** Texas Instruments ADS5485

**Sampling Rate:** 10 MHz to 200 MHz

**Resolution:** 16 bits

**Digital Downconverters (4 or 8)**

**Decimation Range:** 2x to 65,536x in two stages of 2x to 256x

**LO Tuning Freq. Resolution:** 32 bits, 0 to  $f_s$

**LO SFDR:** >120 dB

**Phase Offset Resolution:** 32 bits, 0 to 360 degrees

**FIR Filter:** 18-bit coefficients, 24-bit output, with user programmable coefficients

**Default Filter Set:** 80% bandwidth, <0.3 dB passband ripple, >100 dB stopband attenuation

**Beamformers (1 or 2)**

**Summation:** Four channels on-board; multiple boards can be summed via Summation Expansion Chain

**Summation Expansion Chain:** One chain in and one chain out link via VPX P2 connector using Aurora protocol

**Phase Shift Coefficients:** I & Q with 16-bit resolution

**Gain Coefficients:** 16-bit resolution

**Channel Summation:** 24-bit

**Multiboard Summation Expansion:** 32-bit

**Sample Clock Sources (1 or 2)**

On-board clock synthesizer

**Clock Synthesizers (1 or 2)**

**Clock Source:** Selectable from on-board programmable VCXO (10 to 810 MHz), front panel external clock or LVPECL timing bus

**Synchronization:** VCXO can be locked to an external 4 to 180 MHz PLL system reference, typically 10 MHz

**Clock Dividers:** External clock or VCXO can be divided by 1, 2, 4, 8, or 16 for the A/D clock

**External Clocks (1 or 2)**

**Type:** Front panel female SSMC connector, sine wave, 0 to +10 dBm, AC-coupled, 50 ohms, accepts 10 to 800 MHz divider input clock or PLL system reference

**Timing Bus (1 or 2):** 26-pin connector LVPECL bus includes, clock/sync/gate/PPS inputs and outputs; TTL signal for gate/trigger and sync/PPS inputs

**External Trigger Inputs (1 or 2)**

**Type:** Front panel female SSMC connector, LVTTTL

**Function:** Programmable functions include: trigger, gate, sync and PPS

**Field Programmable Gate Arrays (1 or 2)**

**Standard:** Xilinx Virtex-6 XC6VLX240T

**Optional:** Xilinx Virtex-6 XC6V SX315T

**Custom I/O**

**Option -104:** Provides 20 LVDS pairs between the FPGA and the VPX P3 connector, Model 57661; P3 and P5, Model 58661

**Memory Banks (1 or 2)**

**Option 150 or 160:** Two 8 MB QDR II+ SRAM memory banks, 400 MHz DDR  
**Option 155 or 165:** Two 512 MB DDR3 SDRAM memory banks, 400 MHz DDR

**PCI-Express Interface**

**PCI Express Bus:** Gen. 1 or 2: x4 or x8

**Environmental:** Level L1 & L2 air-cooled; Level L3 ruggedized, conduction-cooled

**Size:** 3.937 in. x 6.717 in. (100 mm x 170.6 mm)

A/D Performance

Spurious Free Dynamic Range

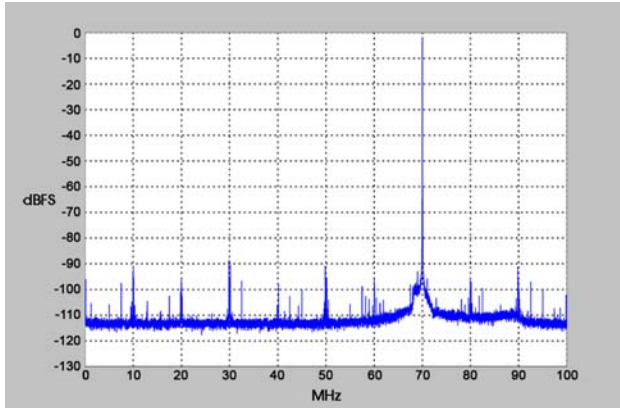

$f_{in} = 70 \text{ MHz}$ ,  $f_s = 200 \text{ MHz}$ , Internal Clock

Spurious Pick-up

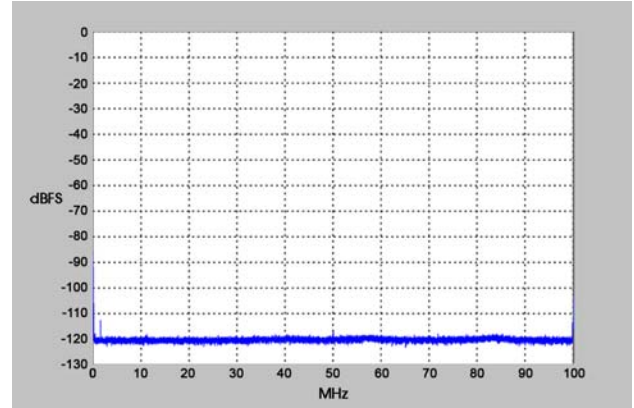

$f_s = 200 \text{ MHz}$ , Internal Clock

Two-Tone SFDR

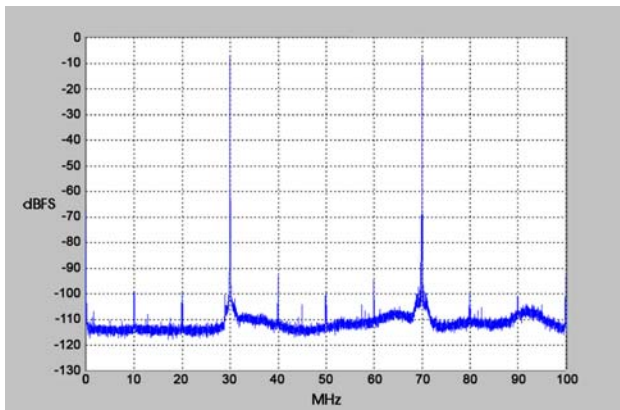

$f_1 = 30 \text{ MHz}$ ,  $f_2 = 70 \text{ MHz}$ ,  $f_s = 200 \text{ MHz}$

Two-Tone SFDR

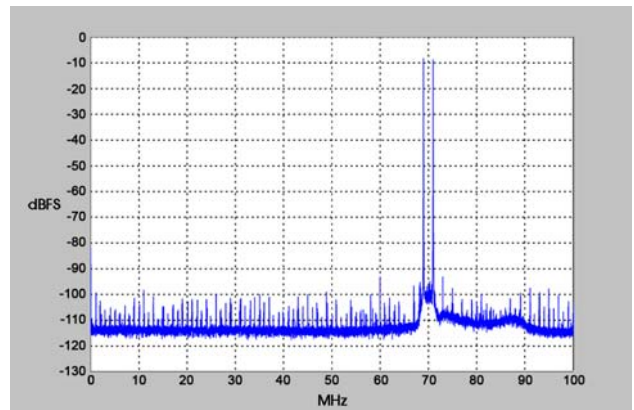

$f_1 = 69 \text{ MHz}$ ,  $f_2 = 71 \text{ MHz}$ ,  $f_s = 200 \text{ MHz}$

Adjacent Channel Crosstalk

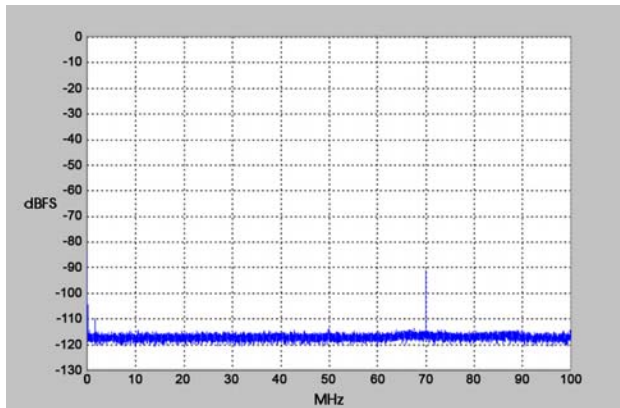

$f_{in \text{ Ch2}} = 70 \text{ MHz}$ ,  $f_s = 200 \text{ MHz}$ , Ch 1 shown

Input Frequency Response

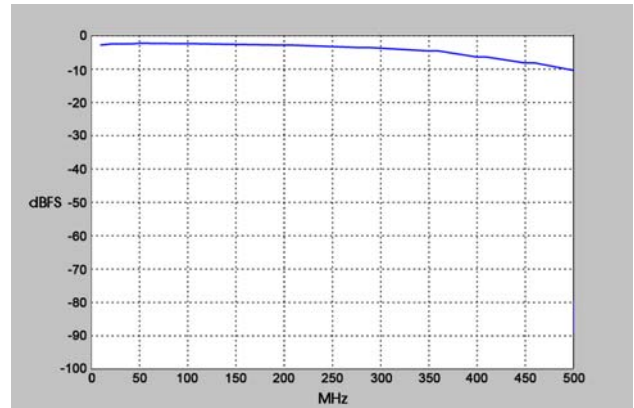

$f_s = 200 \text{ MHz}$ , Internal Clock