

New!

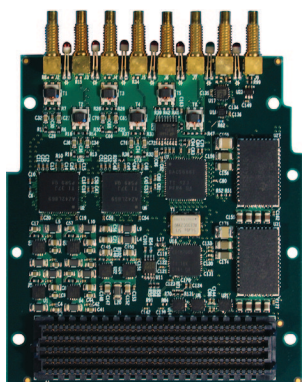

Flexor

ReadyFlow
Board Support Package

GateFlow

NAVIGATOR
Design Suite

Features

- Four 250 MHz 16-bit A/Ds
- One digital upconverter
- Two 800 MHz 16-bit D/As
- Sample clock synchronization to an external system reference
- VITA 57 FMC compatible
- Complete radar or software radio interface solution when combined with the Pentek FMC carriers
- Ruggedized and conduction-cooled versions available

General Information

The Flexor® Model 3312 is a multichannel, high-speed data converter FMC module. It is suitable for connection to HF or IF ports of a communications or radar system. It includes four 250 MHz, 16-bit A/Ds, programmable clocking, and multiboard synchronization for support of larger high-channel count systems.

When combined with a Pentek 3U VPX or a PCIe FMC carrier, the 3312 is available as a FlexorSet, a complete turnkey data acquisition solution. For applications that require custom processing, FlexorSets are ideal for IP development and deployment.

Pentek also offers the option -990 reference design with software and IP support when installed on the Xilinx VC707 Evaluation Kit board.

A/D Converters

The front end accepts four analog HF or IF inputs on front-panel connectors with transformer-coupling into four Texas Instruments ADS42LB69 dual 250 MHz, 16-bit A/D converters.

Performance of the Model 3312

The true performance of the 3312 can be best unlocked when used with the Pentek FMC carriers as a FlexorSet. With factory-installed IP, the board-set provides a turnkey data acquisition subsystem eliminating the need to create any FPGA IP. Installed features include flexible A/D acquisition, programmable linked-list DMA engines, and a metadata packet creator.

A/D Acquisition IP Modules

With the 3312 installed on either the 5973 or the 7070 carrier, the board-set features four A/D acquisition modules for easily capturing and moving data. Each module can receive data from any of the four A/Ds, a test signal generator or from the D/A waveform generator IP module in loopback mode.

Each IP module can have an associated memory bank on the FMC carrier for buffering data in FIFO mode or for storing data in transient capture mode. All memory banks are supported with DMA engines for easily moving A/D data through the FMC carrier's PCIe interface.

These powerful linked-list DMA engines are capable of a unique acquisition gate-driven mode. In this mode, the length of a transfer performed by a link definition need not be known prior to data acquisition; rather, it is governed by the length of the acquisition gate. This is extremely useful in applications where an external gate drives acquisition and the exact length of that gate is not known or is likely to vary.

For each transfer, the DMA engine can automatically construct metadata packets containing A/D channel ID, a sample-accurate time stamp and data length information. These actions simplify the host processor's task of identifying and executing on the data.

When used with the 5973 or the 7070, Pentek's ReadyFlow® BSP provides control of all the 3312's hardware and IP-based functions. Ready to run examples and a fully-sourced C library provide a quick-start and powerful platform to create custom applications. ReadyFlow is compatible with Windows or Linux operating systems.

D/A Waveform Generator IP Module

With the 5973 or the 7070, the 3312 features a sophisticated D/A waveform generator IP module. A linked-list controller allows users to easily record to the D/As wave-forms stored in either on-board or off-board host memory.

Parameters including length of waveform, delay from trigger, waveform repetition, etc. can be programmed for each waveform. ▶

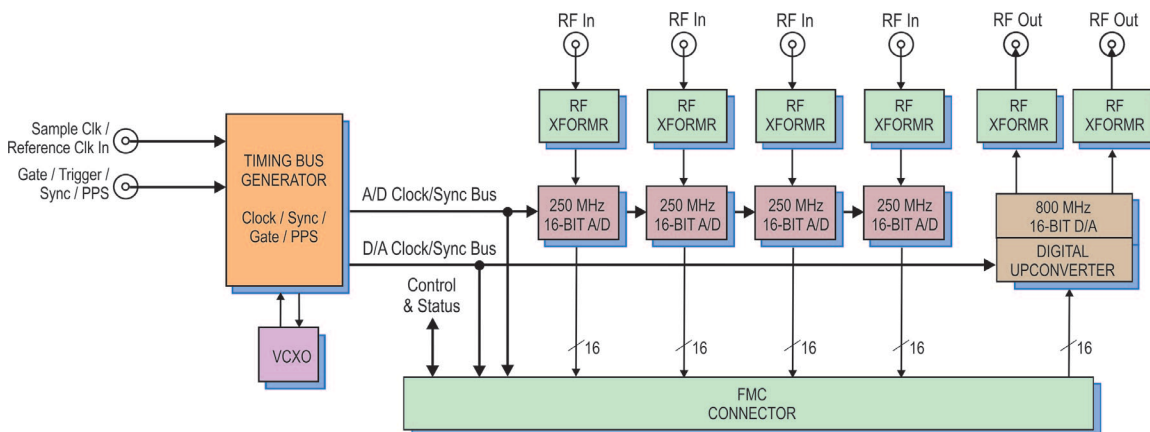

FMC Interface

The Model 3312 complies with the VITA 57 High-Pin-Count FMC specification. The interface provides all data, clocking, synchronization, control and status signals between the 3312 and the FMC carrier.

SPARK Development Systems

SPARK systems are fully-integrated saving engineers and system integrators the time and expense associated with building and testing a development system. SPARK systems ensure the optimum performance of Pentek boards and are available in 3U VPX ([Model 8267](#)) and in a PC environment ([Model 8266](#)).



Ordering Information

Model	Description
3312	4-Channel 250 MHz 16-bit A/D, 2-Channel 800 MHz 16-bit D/A FMC module

Options:

3312-990	Reference design for 3312 installed on Xilinx VC707 Evaluation Kit
--------------------------	--

3U FlexorSet Description

5973-312	4-Channel 250 MHz A/D with Virtex-7 FPGA
5973-313	4-Channel 250 MHz A/D, Virtex-7 FPGA with 4 multiband DDCs and interpolator
5983-313	4-Channel 250 MHz A/D, Kintex UltraScale FPGA with 4 multiband DDCs and interpolator

PCIe FlexorSet Description

7070-312	4-Channel 250 MHz A/D with Virtex-7 FPGA -x8
7070-313	4 Channel 250 MHz A/D, Virtex-7 FPGA with 4 DDCs and interpolator -x8

Contact Pentek for availability of rugged and conduction-cooled versions and other support options

► Up to 64 individual link entries can be chained together to create complex waveforms with minimum programming.

Digital Upconverter and D/A Stage

A TI DAC5688 DUC (digital upconverter) and D/A accepts a baseband real or complex data stream from the FPGA and provides that input to the upconvert, interpolate and D/A stages.

When operating as a DUC, it interpolates and translates real or complex baseband input signals to any IF center frequency from DC to the sampling frequency. It delivers the output to the 16-bit D/A converter. Analog outputs are through front panel connectors.

If translation is disabled, the DAC5688 acts as a dual interpolating 16-bit D/A with output sampling rates up to 800 MHz. In both modes the DAC5688 provides interpolation factors of 2x, 4x and 8x.

Clocking and Synchronization

Two internal timing buses provide all timing and synchronization required by the A/D and D/A converters. Each includes a clock, sync and gate or trigger signals. An on-board clock generator receives an external sample clock from the front panel coaxial connector. This clock can be used directly by the A/D or D/A sections or divided by a built-in clock synthesizer circuit to provide different A/D and D/A clocks. In an alternate mode, the sample clock can be sourced from an on-board programmable VCXO (Voltage-Controlled Crystal Oscillator). In this mode, the front coaxial panel connector can be used to provide a 10 MHz reference clock for synchronizing the internal oscillator.

A front panel LVTTTL Gate/Trigger/Sync connector can receive an external timing signal allowing multiple modules to be synchronized thereby creating larger multi-board systems.

Board Support Packages

Pentek's BSPs provide control of the 3312's hardware and IP-based functions. Ready to run examples and a fully-sourced C library provide a powerful, quick-start platform to create custom applications. BSPs are compatible with Windows and Linux operating systems. ReadyFlow BSP is used with OnyxFX Virtex-7 FPGA carriers and Navigator BSP is used for all new development going forward including the JadeFX Kintex Ultrascale carriers.

Extendable IP Design

For applications that require specialized functions, users can install their own

custom IP for data processing. Using Xilinx Vivado tools, developers can integrate their own IP with the Pentek factory-installed functions or use the development kit to completely replace the Pentek IP with their own.

GateFlow is used with OnyxFX Virtex-7 FPGA carriers and Navigator FDK is used for all new FPGA development going forward including the JadeFX Kintex UltraScale carriers.

Model 3312 Specifications

Front Panel Analog Signal Inputs

Input Type: Transformer-coupled, front panel connectors

Transformer Type: Coil Craft WBC4-6TLB

Full Scale Input: +4 dBm into 50 ohms

3 dB Passband: 300 kHz to 700 MHz

A/D Converters

Type: Texas Instruments ADS42LB69

Sampling Rate: 10 MHz to 250 MHz

Resolution: 16 bits

D/A Converters

Type: Texas Instruments DAC5688

Input Data Rate: 250 MHz max.

Output IF: DC to 400 MHz max.

Output Sampling Rate: 800 MHz max. with interpolation

Resolution: 16 bits

Front Panel Analog Signal Outputs

Output Type: Transformer-coupled, front panel connector

Transformer Type: Coil Craft WBC4-6TLB

Full Scale Output: +4 dBm into 50 ohms

3 dB Passband: 300 kHz to 700 MHz

Sample Clock Sources: On-board clock synthesizer generates two clocks: an A/D clock and a D/A clock

Clock Synthesizer

Clock Source: Selectable from on-board programmable VCXO (10 to 810 MHz) or front panel external clock

Synchronization: VCXO can be phase-locked to an external 4 to 180 MHz PLL system reference, typically 10 MHz

Clock Dividers: External clock or VCXO can be divided by 1, 2, 4, 8, or 16 for the A/D or D/A clocks

External Clock

Type: Front panel connector, sine wave, 0 to +10 dBm, AC-coupled, 50 ohms, accepts 10 to 800 MHz divider input clock or PLL system reference

External Trigger Input

Type: Front panel connector, LVTTTL
Function: Programmable functions include: trigger, gate, sync and PPS

Environmental: Level L1 & L2 air cooled, Level L3 conduction-cooled, ruggedized

I/O Module Interface: VITA-57.1, High-Pin-Count FMC

Pentek FlexorSet Models					
Form Factor	FPGA Type Development Tools	Carrier Model	FMC Model	FlexorSet Model	Description
3U VPX	Virtex-7 ReadyFlow BSP GateFlow FDK Vivado	5973	3312	5973-312	4 Ch 250 MHz A/D & 2 Ch 800 MHz D/A
				5973-313	As above with 4 multiband DDCs & interpolation filters
			3316	5973-316	8 Ch 250 MHz 16-bit A/D
				5973-317	As above with 8 multiband DDCs
	Kintex UltraScale Navigator BSP Navigator FDK Vivado	5983	3312	5983-313	4 Ch 250 MHz A/D & 2 Ch 800 MHz D/A with 4 multiband DDCs & interpolation filters
				5983-317	8 Ch 250 MHz 16-bit A/D with 8 multiband DDCs
			3320	5983-320	2 Ch 3 GHz A/D & 2 Ch 2.8 GHz MHz D/A
				5983-324	4 Ch 500 MHz A/D & 4 Ch 2 GHz D/A
PCIe	Virtex-7 ReadyFlow BSP GateFlow FDK Vivado	7070	3312	7070-312	4 Ch 250 MHz A/D & 2 Ch 800 MHz D/A
				7070-313	As above with 4 multiband DDCs & interpolation filters
			3316	7070-316	8 Ch 250 MHz 16-bit A/D
				7070-317	As above with 8 multiband DDCs
			3320	7070-320	2 Ch 3 GHz A/D & 2 Ch 2.8 GHz MHz D/A
				7070-324	4 Ch 500 MHz A/D & 4 Ch 2 GHz D/A



Model 5973-312



Features

- Supports Xilinx Virtex-7 VXT FPGAs
- GateXpress supports dynamic FPGA reconfiguration across PCIe
- Four 250 MHz 16-bit A/Ds
- One digital upconverter
- Two 800 MHz 16-bit D/As
- 4 GB of DDR3 SDRAM
- Sample clock synchronization to an external system reference
- PCI Express (Gen. 1, 2 & 3) interface up to x8
- User-configurable gigabit serial interface
- Optional optical Interface for backplane gigabit serial interboard communication
- Optional LVDS connections to the Virtex-7 FPGA for custom I/O
- Compatible with several VITA standards including: VITA-46, VITA-48, VITA-66.4 and VITA-65 (OpenVPX™ System Specification)
- Ruggedized and conduction-cooled versions available

General Information

Model 5973-312 is a member of the Flexor® family of high-performance 3U VPX boards based on the Xilinx Virtex-7 FPGA.

As a FlexorSet™ integrated solution, the Model 3312 FMC is factory-installed on the 5973 FMC carrier. The required FPGA IP is installed and the board set is delivered ready for immediate use.

The delivered FlexorSet is a multichannel, high-speed data converter and is suitable for connection to the HF or IF ports of a communications or radar system. Its built-in data capture features offer an ideal turnkey solution as well as a platform for developing and deploying custom FPGA processing IP.

It includes four 250 MHz, 16-bit A/Ds, one digital upconverter, two 800 MHz, 16-bit D/As, and four banks of memory. In addition to supporting PCIe Gen. 3 as a native interface, the Model 5973-312 includes optional copper and optical connections to the Virtex-7 FPGA for custom I/O.

The Flexor Architecture

Based on the proven design of the Pentek Onyx family of Virtex-7 products, the 5973 FMC carrier retains all the key features of that family. As a central foundation of the board architecture, the FPGA has access to all data and control paths of both the carrier board and the FMC module, enabling factory-installed functions that include data multiplexing, channel selection, data packing, gating, triggering and memory control.

When delivered as an assembled board set, the 5973-312 includes factory-installed applications ideally matched to the board's analog interfaces. The functions include four A/D acquisition IP modules for simplifying data capture and data transfer.

Each of the four acquisition IP modules contains IP modules for DDR3 SDRAM memories.

The 5973-312 features a sophisticated D/A waveform playback IP module. A linked-list controller allows users to easily play back to the D/As waveforms stored in either on-board or off-board host memory. Parameters including length of waveform, delay from playback trigger, waveform repetition, etc. can be programmed for each waveform.

Up to 64 individual link entries can be chained together to create complex waveforms with a minimum of programming.

A controller for all data clocking and synchronization functions, a test signal generator, and a PCIe interface complete the factory-installed functions and enable the 5973-312 to operate as a turnkey solution without the need to develop any FPGA IP.

Extendable IP Design

For applications that require specialized functions, users can install their own custom IP for data processing. Pentek GateFlow® FPGA Design Kits include all of the factory-installed modules as documented source code. Developers can integrate their own IP with the Pentek factory-installed functions or use the GateFlow kit to completely replace the Pentek IP with their own. ➤

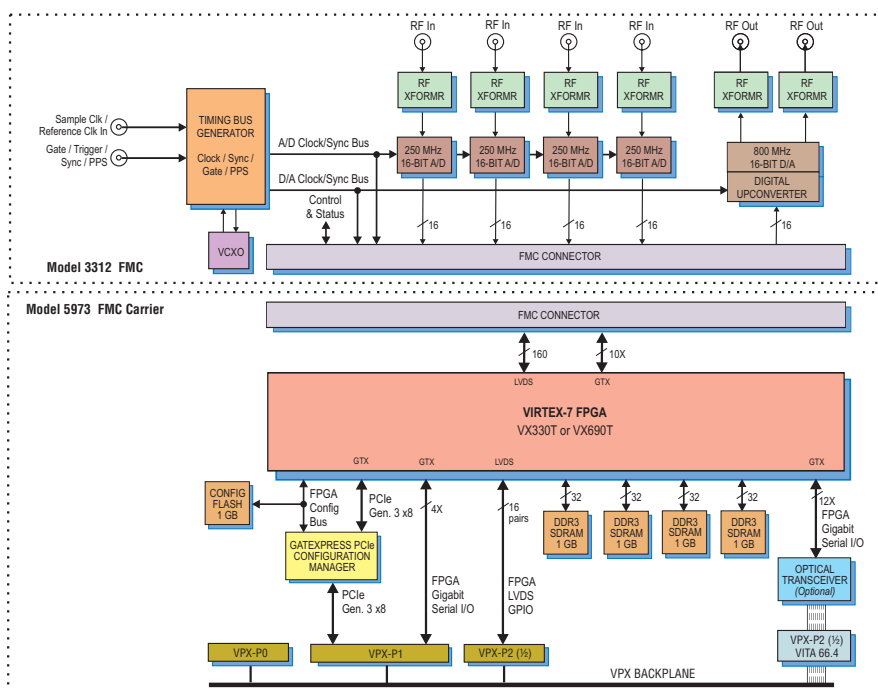

A/D Acquisition IP Modules

The 5973-312 features four A/D Acquisition IP Modules for easy capture and data moving. Each IP module can receive data from any of the four A/Ds, a test signal generator or from the D/A Waveform Playback IP Module in loopback mode.

Each IP module has an associated memory bank for buffering data in FIFO mode or for storing data in transient capture mode. All memory banks are supported with DMA engines for moving A/D data through the PCIe interface.

These powerful linked-list DMA engines are capable of a unique Acquisition Gate Driven mode. In this mode, the length of a transfer performed by a link definition need not be known prior to data acquisition; rather, it is governed by the length of the acquisition gate. This is extremely useful in applications where an external gate drives acquisition and the exact length of that gate is not known or is likely to vary.

For each transfer, the DMA engine can automatically construct metadata packets containing A/D channel ID, a sample accurate time stamp, and data length information. These actions simplify the host processor's job of identifying and executing on the data.

D/A Waveform Playback IP Module

The 5973-312 factory-installed functions include a sophisticated D/A Waveform Playback IP module. A linked-list controller allows users to easily playback waveforms stored in either on-board or off-board host memory to the dual D/As.

Parameters including length of waveform, delay from playback trigger, waveform repetition, etc. can be programmed for each waveform. Up to 64 individual link entries can be chained together to create complex waveforms with a minimum of programming.

Xilinx Virtex-7 FPGA

The 5973-312 can be optionally populated with one of two Virtex-7 FPGAs to match the specific requirements of the processing task. Supported FPGAs are VX330T or VX690T. The VX690T features 3600 DSP48E1 slices and is ideal for modulation/demodulation, encoding/decoding, encryption/decryption, and channelization of the signals between transmission and reception. For applications not requiring large DSP resources or logic, the lower-cost VX330T can be installed.

A 4X connection between the FPGA and the VPX P1 connector supports gigabit serial protocols.

Option -104 provides 16 pairs of LVDS connections between the FPGA and the VPX P2 connector for custom I/O.

Option -110 supports the VITA-66.4 standard that provides 12 optical duplex lanes to the backplane. With the installation of a serial protocol, the VITA-66.4 interface enables gigabit backplane communications between boards independent of the PCIe interface.

GateXpress for FPGA Configuration

The Flexor architecture includes GateXpress®, a sophisticated FPGA-PCIe configuration manager for loading and re-loading the FPGA. At power-up, GateXpress immediately presents a PCIe target for the host computer to discover, effectively giving the FPGA time to load from FLASH.

This is especially important for larger FPGAs where the loading times can exceed the PCIe discovery window, typically 100 msec on many systems.

The board's configuration FLASH can hold four FPGA images. Images can be factory-installed IP or custom IP created by the user, and programmed into the FLASH via JTAG using Xilinx iMPACT or through the board's PCIe interface. At power-up the user can choose which image will load based on a hardware switch setting.

Once booted, GateXpress allows the user three options for dynamically reconfiguring the FPGA with a new IP image. The first option to load is an alternate image from FLASH through software control. The user selects the desired image and issues a reload command.

The second option is for applications where the FPGA image must be loaded directly through the PCIe interface. This is important in security situations where there can be no latent user image left in non-volatile memory when power is removed. In applications where the FPGA IP may need to change many times during the course of a mission, images can be stored on the host computer and loaded through PCIe as needed.

The third option, typically used during development, allows the user to directly load the FPGA through JTAG using Xilinx iMPACT. ➤

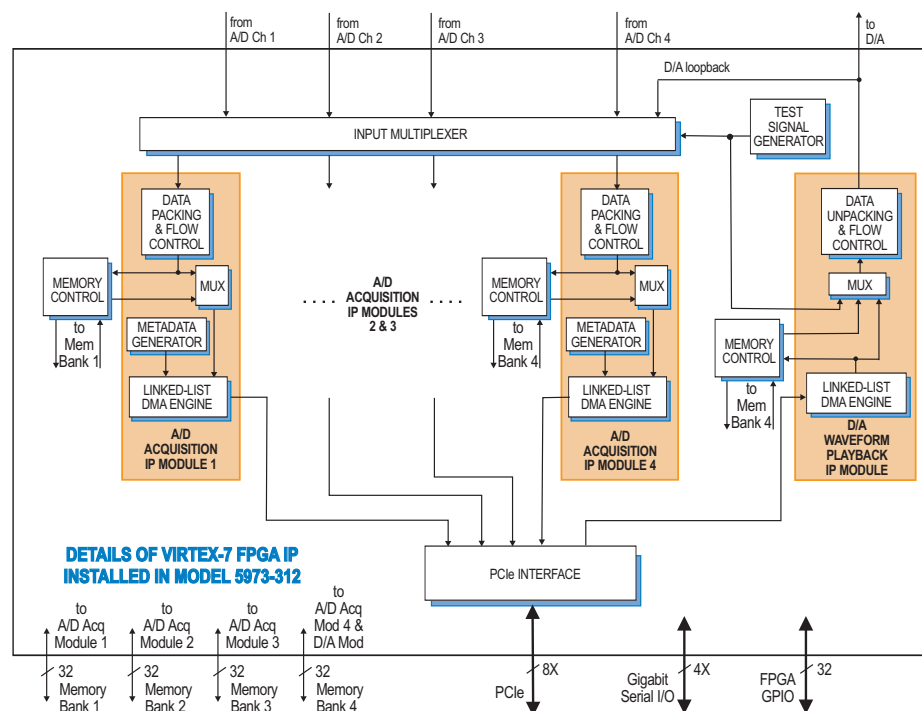

PCI Express Interface

The Model 5973-312 includes an industry-standard interface fully compliant with PCI Express Gen. 1, 2 and 3 bus specifications. Supporting PCIe links up to x8, the interface includes multiple DMA controllers for efficient transfers to and from the board.

Memory Resources

The 5973-312 architecture supports four independent DDR3 SDRAM memory banks. Each bank is 1 GB deep and is an integral part of the board's DMA capabilities, providing FIFO memory space for creating DMA packets.

SPARK Development Systems

The Model 8267 is a fully-integrated development system for Pentek 3U VPX boards. It was created to save engineers and system integrators the time and expense associated with building and testing a development system that ensures optimum performance of Pentek boards.



Ordering Information

Model	Description
5973-312	4-Channel 250 MHz A/D, 2-Channel 800 MHz 16-bit D/A with Virtex-7 FPGA - 3U VPX

Options:

-076	XC7VX690T-2 FPGA
-104	LVDS FPGA I/O to VPX P2
-110	VITA-66.4 12X optical interface

Contact Pentek for availability of rugged and conduction-cooled versions

Model	Description
8267	VPX Development System See 8267 Datasheet for Options

► In all three FPGA loading scenarios, GateXpress handles the hardware negotiation simplifying and streamlining the loading task. In addition, GateXpress preserves the PCIe configuration space allowing dynamic FPGA reconfiguration without needing to reset the host computer to rediscover the board. After the reload, the host simply continues to see the board with the expected device ID.

A/D Converter Stage

The front end accepts four analog HF or IF inputs on front-panel connectors with transformer-coupling into two Texas Instruments ADS42LB69 dual 250 MHz, 16-bit A/D converters.

Digital Upconverter and D/A Stage

A TI DAC5688 DUC and D/A accepts a baseband real or complex data stream from the FPGA and provides that input to the upconvert, interpolate and D/A stages.

When operating as a DUC, it interpolates and translates real or complex baseband input signals to any IF center frequency up to 360 MHz. It delivers the output to the 16-bit D/A converter. Analog outputs are through front panel connectors.

If translation is disabled, the DAC5688 acts as a dual interpolating 16-bit D/A with output sampling rates up to 800 MHz. In both modes the DAC5688 provides interpolation factors of 2x, 4x and 8x.

Clocking and Synchronization

Two internal timing buses provide all timing and synchronization required by the A/D and D/A converters. Each includes a clock, sync and gate or trigger signals. An on-board clock generator receives an external sample clock from the front panel coaxial connector. This clock can be used directly by the A/D or D/A sections or divided by a built-in clock synthesizer circuit to provide different A/D and D/A clocks. In an alternate mode, the sample clock can be sourced from an on-board programmable VCXO. In this mode, the front coaxial panel connector can be used to provide a 10 MHz reference clock for synchronizing the internal oscillator.

A front panel LVTTTL Gate/Trigger/Sync connector can receive an external timing signal to synchronize multiple modules.

Specifications

Front Panel Analog Signal Inputs

Input Type: Transformer-coupled, front panel connectors

Transformer Type: Coil Craft WBC4-6TLB

Full Scale Input: +4 dBm into 50 ohms

3 dB Passband: 300 kHz to 700 MHz

A/D Converters

Type: Texas Instruments ADS42LB69

Sampling Rate: 10 MHz to 250 MHz

Resolution: 16 bits

D/A Converters

Type: Texas Instruments DAC5688

Input Data Rate: 250 MHz max.

Output IF: DC to 400 MHz max.

Output Sampling Rate: 800 MHz max. with interpolation

Resolution: 16 bits

Front Panel Analog Signal Outputs

Output Type: Transformer-coupled, front panel connector

Transformer Type: Coil Craft WBC4-6TLB

Full Scale Output: +4 dBm into 50 ohms

3 dB Passband: 300 kHz to 700 MHz

Sample Clock Sources: On-board clock synthesizer generates two clocks: an A/D clock and a D/A clock

Clock Synthesizer

Clock Source: Selectable from on-board programmable VCXO (10 to 810 MHz), front panel external clock or LVPECL timing bus

Synchronization: VCXO can be locked to an external 4 to 180 MHz PLL system reference, typically 10 MHz

Clock Dividers: External clock or VCXO can be divided by 1, 2, 4, 8 or 16 for the A/D clock

External Clock

Type: Front panel female SSMC connector, sine wave, 0 to +10 dBm, AC-coupled, 50 ohms, accepts 10 to 800 MHz divider input clock or PLL system reference

External Trigger Input

Type: Front panel connector

Function: Programmable functions include: trigger, gate, sync and PPS

Field Programmable Gate Array

Standard: Xilinx Virtex-7 XC7VX330T-2

Option -076: Xilinx Virtex-7 XC7VX690T-2

Custom FPGA I/O

4X gigabit links between the FPGA and the VPX P1 connector to support serial protocols.

Parallel (Option -104): 16 pairs of LVDS connections between the FPGA and the VPX P2 connector for custom I/O

Optical (Option -110): VITA-66.4, 12X duplex lanes

Memory

Type: DDR3 SDRAM

Size: Four banks, 1 GB each

Speed: 800 MHz (1600 MHz DDR)

PCI-Express Interface

PCI Express Bus: Gen. 1, 2 or 3: x4 or x8;

Environmental: Level L1 & L2 air-cooled,

Level L3 conduction-cooled, ruggedized

Size: 3.937 in. x 6.717 in. (100 mm x 170.6 mm)



Model 5973-313



Features

- Includes Xilinx Virtex-7 FPGAs
- GateXpress supports dynamic FPGA reconfiguration across PCIe
- Four 250 MHz 16-bit A/Ds
- Four multiband DDCs
- One digital upconverter
- Two 800 MHz 16-bit D/As
- Extended Interpolation
- Sample clock synchronization to an external system reference
- PCI Express (Gen. 1, 2 & 3) interface up to x8
- User-configurable gigabit serial interface
- Optional optical interface for backplane gigabit serial interboard communication
- LVDS connections to the Virtex-7 FPGA for custom I/O and synchronization
- Compatible with several VITA standards including: VITA-46, VITA-48, VITA-66.4 and VITA-65 (OpenVPX™ System Specification)
- Ruggedized and conduction-cooled versions available

General Information

Model 5973 is a member of the OnyxFX® family of high-performance 3U VPX baseboards with a Xilinx Virtex-7 FPGA and an available FMC I/O slot.

As an integrated solution, the Model 5973-313 FlexorSet™ combines the Model 5973 and the Model 3312 Flexor® FMC as a factory-installed set. The required FPGA IP is installed and the board set is delivered ready for immediate use.

The delivered FlexorSet is a multi-channel, high-speed data converter with programmable DDCs and is suitable for connection to HF or IF ports of a communications or radar system. Its built-in data capture features offer an ideal turnkey solution as well as a platform for developing and deploying custom FPGA-processing IP.

The Model 5973-313 includes four 250 MHz, 16-bit A/Ds, one digital upconverter, two 800 MHz, 16-bit D/As, and four banks of memory. In addition to supporting PCIe Gen. 3 as a native interface, it includes optional copper and optical connections to the Virtex-7 FPGA for custom I/O.

The Flexor Architecture

Based on the proven design of the Pentek Onyx family of Virtex-7 products, the 5973 FMC carrier retains all the key features of that family. As a central foundation of the board architecture, the FPGA has access to all data and control paths of both the carrier board and the FMC module, enabling factory-installed functions that include data multiplexing, channel selection, data packing, gating, triggering and memory control.

When delivered as an assembled board set, the 5973-313 includes factory-installed applications ideally matched to the board's analog interfaces. The functions include four A/D acquisition IP modules for simplifying data capture and data transfer.

Each of the four acquisition IP modules contains a powerful DDC core.

The 5973-313 features a sophisticated D/A waveform generator IP module. A linked-list controller allows users to easily record to the D/As waveforms stored in either on-board or off-board host memory. Parameters including length of waveform, delay from trigger, waveform repetition, etc. can be programmed for each waveform.

Up to 64 individual link entries can be chained together to create complex waveforms with a minimum of programming.

A controller for all data clocking and synchronization functions, a test signal generator, and a PCIe interface complete the factory-installed functions and enable the 5973-313 to operate as a turnkey solution without the need to develop any FPGA IP.

Extendable IP Design

For applications that require specialized functions, users can install their own custom IP for data processing. Pentek GateFlow® FPGA Design Kits include all of the factory-installed modules as documented source code. Developers can integrate their own IP with the Pentek factory-installed functions or use the GateFlow kit to completely replace the Pentek IP with their own. ➤

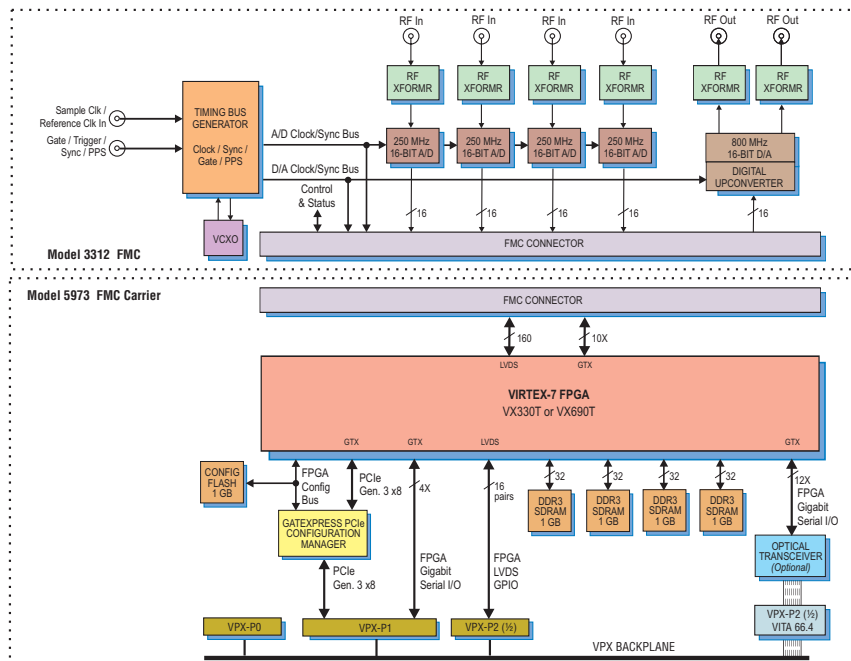

A/D Acquisition IP Modules

The 5973-313 features four A/D Acquisition IP Modules for easy capture and data moving. Each IP module can receive data from any of the four A/Ds, a test signal generator or from the D/A Waveform Generator IP Module in loopback mode.

Each IP module has an associated memory bank for buffering data in FIFO mode or for storing data in transient capture mode. All memory banks are supported with DMA engines for moving A/D data through the PCIe interface.

These powerful linked-list DMA engines are capable of a unique Acquisition Gate Driven mode. In this mode, the length of a transfer performed by a link definition need not be known prior to data acquisition; rather, it is governed by the length of the acquisition gate. This is extremely useful in applications where an external gate drives acquisition and the exact length of that gate is not known or is likely to vary.

For each transfer, the DMA engine can automatically construct metadata packets containing A/D channel ID, a sample accurate time stamp, and data length information. These actions simplify the host processor's job of identifying and executing on the data.

D/A Waveform Generator IP Module

The 5973-313 factory-installed functions include a sophisticated D/A Waveform Generator IP module. A linked-list controller allows users to easily record waveforms stored in either on-board or off-board host memory to the dual D/As.

Parameters including length of waveform, delay from trigger, waveform repetition, etc. can be programmed for each waveform. Up to 64 individual link entries can be chained together to create complex waveforms with a minimum of programming.

DDC IP Cores

Within each A/D Acquisition IP Module is a powerful DDC IP core. Because of the flexible input routing of the A/D Acquisition IP Modules, many different configurations can be achieved including one A/D driving all four DDCs or each of the four A/Ds driving its own DDC.

Each DDC has an independent 32-bit tuning frequency setting that ranges from DC to f_s , where f_s is the A/D sampling frequency. Each DDC can have its own unique decimation setting, supporting as many as four different output bandwidths for the board. Decimations can be program-med from 2 to 65,536 providing a wide range to satisfy most applications.

The decimating filter for each DDC accepts a unique set of user-supplied 18-bit coefficients. The 80% default filters deliver an output bandwidth of $0.8 \cdot f_s / N$, where N is the decimation setting. The rejection of adjacent-band components within the 80% output bandwidth is better than 100 dB. Each DDC delivers a complex output stream consisting of 24-bit I + 24-bit Q or 16-bit I + 16-bit Q samples at a rate of f_s / N .

Each DDC core contains programmable I & Q phase and gain adjustments followed by a power meter that continuously measures the individual average power output. The time constant of the averaging interval for each meter is programmable up to 8K samples. The power meters present

average power measurements for each DDC core output in easy-to-read registers.

In addition, each DDC core includes a threshold detector to automatically send an interrupt to the processor if the average power level of any DDC core falls below or exceeds a programmable threshold.

► Xilinx Virtex-7 FPGA

The 5973-313 can be optionally populated with one of two Virtex-7 FPGAs to match the specific requirements of the processing task. Supported FPGAs are VX330T or VX690T. The VX690T features 3600 DSP48E1 slices and is ideal for modulation/demodulation, encoding/decoding, encryption/decryption, and channelization of the signals between transmission and reception. For applications not requiring large DSP resources or logic, the lower-cost VX330T can be installed.

A 4X connection between the FPGA and the VPX P1 connector supports gigabit serial protocols. Sixteen pairs of LVDS connections between the FPGA and the VPX P2 connector for synchronization and custom I/O.

Option -110 supports the VITA-66.4 standard that provides 12 optical duplex lanes to the backplane. With the installation of a serial protocol, the VITA-66.4 interface enables gigabit backplane communications between boards independent of the PCIe interface. ►

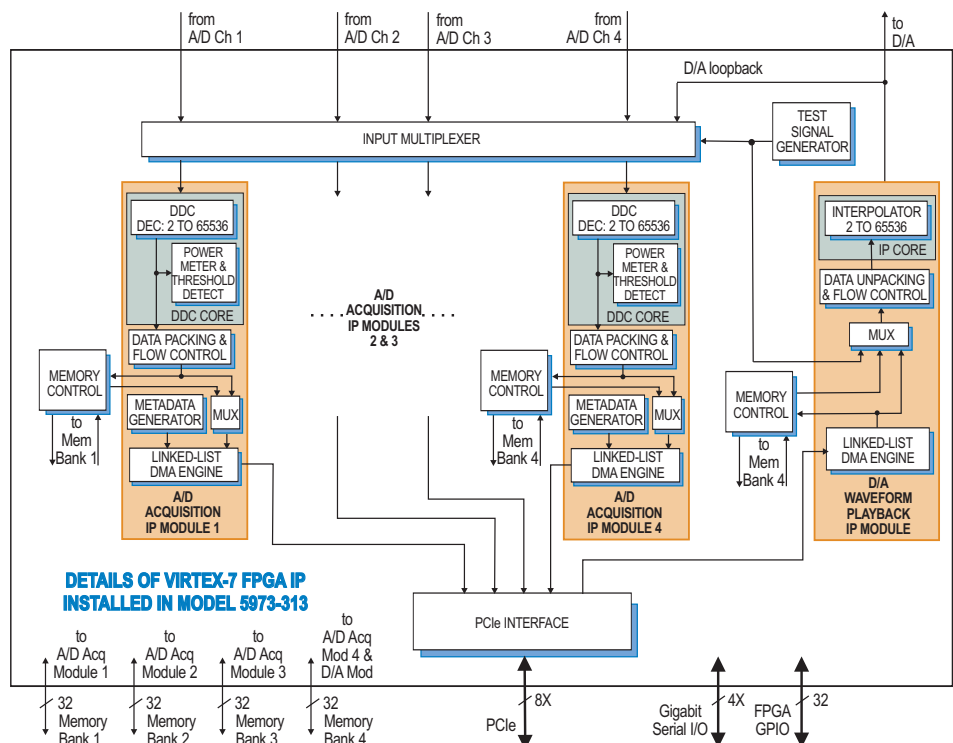

► GateXpress for FPGA Configuration

The Flexor architecture includes GateXpress®, a sophisticated FPGA-PCIe configuration manager for loading and reloading the FPGA. At power-up, Gate-Xpress immediately presents a PCIe target for the host computer to discover, effectively giving the FPGA time to load from FLASH. This is especially important for larger FPGAs where the loading times can exceed the PCIe discovery window, typically 100 msec on many systems.

The board's configuration FLASH can hold four FPGA images. Images can be factory-installed IP or custom IP created by the user, and programmed into the FLASH via JTAG using Xilinx iMPACT or through the board's PCIe interface. At power-up the user can choose which image will load based on a hardware switch setting.

Once booted, GateXpress allows the user three options for dynamically reconfiguring the FPGA with a new IP image. The first option to load is an alternate image from FLASH through software control. The user selects the desired image and issues a reload command.

The second option is for applications where the FPGA image must be loaded directly through the PCIe interface. This is important in security situations where there can be no latent user image left in non-volatile memory when power is removed. In applications where the FPGA IP may need to change many times during the course of a mission, images can be stored on the host computer and loaded through PCIe as needed.

The third option, typically used during development, allows the user to directly load the FPGA through JTAG using Xilinx iMPACT. In all three FPGA loading scenarios, GateXpress handles the hardware negotiation simplifying and streamlining the loading task. In addition, GateXpress preserves the PCIe configuration space allowing dynamic FPGA reconfiguration without needing to reset the host computer to rediscover the board. After the reload, the host simply continues to see the board with the expected device ID.

A/D Converter Stage

The front end accepts four analog HF or IF inputs on front-panel connectors with transformer-coupling into two Texas Instruments ADS42LB69 dual 250 MHz, 16-bit A/D converters.

Digital Upconverter and D/A Stage

A TI DAC5688 DUC and D/A accepts a baseband real or complex data stream from the FPGA and provides that input to the upconvert, interpolate and D/A stages.

When operating as a DUC, it interpolates and translates real or complex baseband input signals to any IF center frequency from DC to the sampling frequency. It delivers the output to the 16-bit D/A converter. Analog outputs are through front panel connectors.

If translation is disabled, the DAC5688 acts as a dual interpolating 16-bit D/A with output sampling rates up to 800 MHz. In both modes the DAC5688 provides interpolation factors of 2x, 4x and 8x.

In addition, the FPGA-based interpolator provides a range of 2x to 65536x in two stages of 2x to 256x. Including the DAC5688 interpolation, the overall available interpolation range equals 2x to 524,288x.

Clocking and Synchronization

Two internal timing buses provide all timing and synchronization required by the A/D and D/A converters. Each includes a clock, sync and gate or trigger signals. An on-board clock generator receives an external sample clock from the front panel coaxial connector.

This clock can be used directly by the A/D or D/A sections or divided by a built-in clock synthesizer circuit to provide different A/D and D/A clocks. In an alternate mode, the sample clock can be sourced from an on-board programmable VCXO. In this mode, the front-panel coaxial connector can be used to provide a 10 MHz reference clock for synchronizing the internal oscillator.

A front panel LVTTTL Gate/Trigger/Sync connector can receive an external timing signal to synchronize multiple modules. ►

SPARK Development Systems

The Model 8267 is a fully-integrated development system for Pentek 3U VPX boards. It was created to save engineers and system integrators the time and expense associated with building and testing a development system that ensures optimum performance of Pentek boards.



Ordering Information

Model	Description
5973-313	4-Channel 250 MHz 16-bit A/D, with DDCs, 2-Channel 800 MHz 16-bit D/A with DUC, Extended Interpolation and Virtex-7 FPGA - 3U VPX

Options:

-076	XC7VX690T-2 FPGA
-110	VITA-66.4 12X optical I/O with XC7VX690T FPGA, 4X w. XC7VX330T

Contact Pentek for availability of rugged and conduction-cooled versions

Model	Description
8267	VPX Development System See 8267 Datasheet for Options

► PCI Express Interface

The Model 5973-313 includes an industry-standard interface fully compliant with PCI Express Gen. 1, 2 and 3 bus specifications. Supporting PCIe links up to x8, the interface includes multiple DMA controllers for efficient transfers to and from the board.

Memory Resources

The 5973-313 architecture supports four independent DDR3 SDRAM memory banks. Each bank is 1 GB deep and is an integral part of the board's DMA capabilities, providing FIFO memory space for creating DMA packets.

Specifications

Front Panel Analog Signal Inputs

Input Type: Transformer-coupled, front panel connectors

Transformer Type: Coil Craft WBC4-6TLB

Full Scale Input: +4 dBm into 50 ohms

3 dB Passband: 300 kHz to 700 MHz

A/D Converters

Type: Texas Instruments ADS42LB69

Sampling Rate: 10 MHz to 250 MHz

Resolution: 16 bits

4-Channel Digital Downconverter

Decimation Range: 2x to 65,536x in

two stages of 2x to 256x

LO Tuning Freq. Resolution: 32 bits, 0 to f_s

LO SFDR: >120 dB

Phase Offset Resolution: 32 bits, 0 to 360 degrees

FIR Filter: 18-bit user-programmable coefficients, 24-bit output

Default Filter Set: 80% bandwidth, <0.3 dB passband ripple, >100 dB stopband attenuation

Phase Shift Coefficients: I & Q with 16-bit resolution

Gain Coefficients: 16-bit resolution

D/A Converters

Type: Texas Instruments DAC5688

Input Data Rate: 250 MHz max.

Output IF: DC to 400 MHz max.

Output Sampling Rate: 800 MHz max. with interpolation

Resolution: 16 bits

Digital Interpolator

Interpolation Range: 2x to 65,536x in two stages of 2x to 256x

Total Interpolation Range

D/A and digital combined: 2x to 524,288x

Front Panel Analog Signal Outputs

Output Type: Transformer-coupled, front panel connector

Transformer Type: Coil Craft WBC4-6TLB

Full Scale Output: +4 dBm into 50 ohms

3 dB Passband: 300 kHz to 700 MHz

Sample Clock Sources: On-board clock synthesizer generates two clocks: an A/D clock and a D/A clock

Clock Synthesizer

Clock Source: Selectable from on-board programmable VCXO (10 to 810 MHz), front panel external clock or LVPECL timing bus

Synchronization: VCXO can be locked to an external 4 to 180 MHz PLL system reference, typically 10 MHz

Clock Dividers: External clock or VCXO can be divided by 1, 2, 4, 8 or 16 for the A/D clock

External Clock

Type: Front panel female SSMC connector, sine wave, 0 to +10 dBm, AC-coupled, 50 ohms, accepts 10 to 800 MHz divider input clock or PLL system reference

External Trigger Input

Type: Front panel connector

Function: Programmable functions include: trigger, gate, sync and PPS

Field Programmable Gate Array

Standard: Xilinx Virtex-7 XC7VX330T-2

Option -076: Xilinx Virtex-7 XC7VX690T-2

Custom FPGA I/O

4X gigabit links between the FPGA and the VPX P1 connector to support serial protocols.

Parallel: 16 pairs of LVDS connections between the FPGA and the VPX P2 connector for synchronization and custom I/O

Optical (Option -110): VITA-66.4, 12X duplex lanes

Memory

Type: DDR3 SDRAM

Size: Four banks, 1 GB each

Speed: 800 MHz (1600 MHz DDR)

PCI-Express Interface

PCI Express Bus: Gen. 1, 2 or 3: x4 or x8;

Environmental: Level L1 & L2 air-cooled, Level L3 conduction-cooled, ruggedized

Size: 3.937 in. x 6.717 in. (100 mm x 170.6 mm)

New!

FlexorSet Model 5983-313

4-Ch. 250 MHz 16-bit A/D with DDCs, 2-Ch. 800 MHz 16-bit D/A with DUC and Extended Interpolation - 3U VPX



Model 5983-313



Features

- VITA-57.4 HSPC FMC+ site offers access to a wide range of possible I/O
- Supports Xilinx Kintex UltraScale FPGA
- Four 250 MHz 16-bit A/Ds
- Four multiband DDCs
- One digital upconverter
- Two 800 MHz 16-bit D/As
- Extended Interpolation
- Sample clock synchronization to an external system reference
- PCI Express (Gen. 1, 2 & 3) interface up to x8
- User-configurable gigabit serial interface
- Optional optical Interface for backplane gigabit serial interboard communication
- LVDS connections to the Kintex UltraScale FPGA for custom I/O and synchronization
- Compatible with several VITA standards including: VITA-46, VITA-48, VITA-66.4 and VITA-65 (OpenVPX™ System Specification)
- Ruggedized and conduction-cooled versions available

General Information

Model 5983 is a member of the JadeFX™ family of high-performance 3U VPX base-boards with a Xilinx Kintex UltraScale FPGA and an available FMC I/O slot.

As an integrated solution, the Model 5983-313 FlexorSet™ combines the Model 5983 and the Model 3313 Flexor® FMC as a factory-installed set. The required FPGA IP is installed and the board set is delivered ready for immediate use.

The delivered FlexorSet is a multichannel, high-speed data converter with programmable DDCs and is suitable for connection to HF or IF ports of a communications or radar system. Its built-in data capture features offer an ideal turnkey solution as well as a platform for developing and deploying custom FPGA-processing IP.

In addition to the Gen. 3 x8 PCIe interface, the 5983 architecture includes an optional built-in gigabit serial optical interface. Up to 12 high-speed duplex optical lanes are available on a VITA-66.4 connector. With the installation of a serial protocol in the FPGA, this interface enables a high-bandwidth connection between 5983s mounted in the same chassis or even over extended distances between them.

The Flexor Architecture

Based on the proven design of the Pentek Jade family of Kintex products, the 5983 FMC carrier retains all the key features of that family. As a central foundation of the board architecture, the FPGA has access to all data and control paths of both the carrier board and the FMC module, enabling

factory-installed functions that include data multiplexing, channel selection, data packing, gating, triggering and memory control.

When delivered as an assembled board set, the 5983-313 includes factory-installed applications ideally matched to the board's analog interfaces. The functions include four A/D acquisition IP modules for simplifying data capture and data transfer. Each of the four acquisition IP modules contains a powerful DDC core.

The 5983-313 features a sophisticated D/A waveform generator IP module. A linked-list controller allows users to easily record to the D/As waveforms stored in either on-board or off-board host memory. Parameters including length of waveform, delay from trigger, waveform repetition, etc. can be programmed for each waveform.

Up to 64 individual link entries can be chained together to create complex waveforms with a minimum of programming.

A controller for all data clocking and synchronization functions, a test signal generator, and a PCIe interface complete the factory-installed functions and enable the 5983-313 to operate as a turnkey solution without the need to develop any FPGA IP.

Extendable IP Design

For applications that require specialized functions, users can install their own custom IP for data processing. The Pentek Navigator FPGA Design Kits include the board's entire FPGA design as a block diagram that can be edited in Xilinx's Vivado tool suite. In addition, all source code and complete IP core documentation is included. Developers can ➤

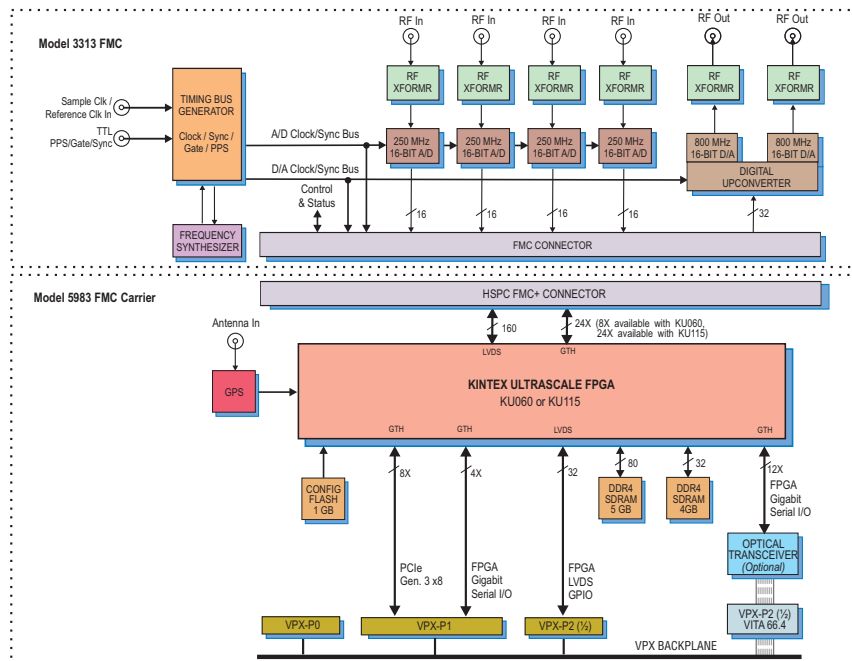

A/D Acquisition IP Modules

The 5983-313 features four A/D Acquisition IP Modules for easy capture and data moving. Each IP module can receive data from any of the four A/Ds, a test signal generator or from the D/A Waveform Generator IP Module in loopback mode.

Each IP module has an associated memory bank for buffering data in FIFO mode or for storing data in transient capture mode. All memory banks are supported with DMA engines for moving A/D data through the PCIe interface.

These powerful linked-list DMA engines are capable of a unique Acquisition Gate Driven mode. In this mode, the length of a transfer performed by a link definition need not be known prior to data acquisition; rather, it is governed by the length of the acquisition gate. This is extremely useful in applications where an external gate drives acquisition and the exact length of that gate is not known or is likely to vary.

For each transfer, the DMA engine can automatically construct metadata packets containing A/D channel ID, a sample accurate time stamp, and data length information. These actions simplify the host processor's job of identifying and executing on the data.

D/A Waveform Generator IP Module

The 5983-313 factory-installed functions include a sophisticated D/A Waveform Generator IP module. A linked-list controller allows users to easily record waveforms stored in either on-board or off-board host memory to the dual D/As.

Parameters including length of waveform, delay from trigger, waveform repetition, etc. can be programmed for each waveform. Up to 64 individual link entries can be chained together to create complex waveforms with a minimum of programming.

DDC IP Cores

Within each A/D Acquisition IP Module is a powerful DDC IP core. Because of the flexible input routing of the A/D Acquisition IP Modules, many different configurations can be achieved including one A/D driving all four DDCs or each of the four A/Ds driving its own DDC.

Each DDC has an independent 32-bit tuning frequency setting that ranges from DC to f_s , where f_s is the A/D sampling frequency. Each DDC can have its own unique decimation setting, supporting as many as four different output bandwidths for the board. Decimations can be program-med from 2 to 65,536 providing a wide range to satisfy most applications.

The decimating filter for each DDC accepts a unique set of user-supplied 18-bit coefficients. The 80% default filters deliver an output bandwidth of $0.8 * f_s / N$, where N is the decimation setting. The rejection of adjacent-band components within the 80% output bandwidth is better than 100 dB. Each DDC delivers a complex output stream consisting of 24-bit I + 24-bit Q or 16-bit I + 16-bit Q samples at a rate of f_s / N .

Each DDC core contains programmable I & Q phase and gain adjustments followed by a power meter that continuously measures the individual average power output. The time constant of the averaging interval for each meter is programmable up to 8K samples. The power

meters present average power measurements for each DDC core output in easy-to-read registers.

In addition, each DDC core includes a threshold detector to automatically send an interrupt to the processor if the average power level of any DDC core falls below or exceeds a programmable threshold.

- integrate their own IP along with the Pentek factory-installed functions or use the Navigator kit to completely replace the Pentek IP with their own.

Xilinx Kintex UltraScale FPGA

The 5983-313 can be optionally populated with one of two Kintex UltraScale FPGAs to match the specific requirements of the processing task. Supported FPGAs are KU060 or KU115. The KU115 features 5520 DSP48E2 slices and is ideal for modulation/demodulation, encoding/decoding, encryption/decryption, and channelization of the signals between transmission and reception. For applications not requiring large DSP resources or logic, the lower-cost KU060 can be installed.

Sixteen pairs of LVDS connections are optionally provided between the FPGA and the VPX P2 connector for custom I/O. For applications requiring custom gigabit links, a 4X connection is supported between the FPGA and the VPX P1 connector to support serial protocols. ►

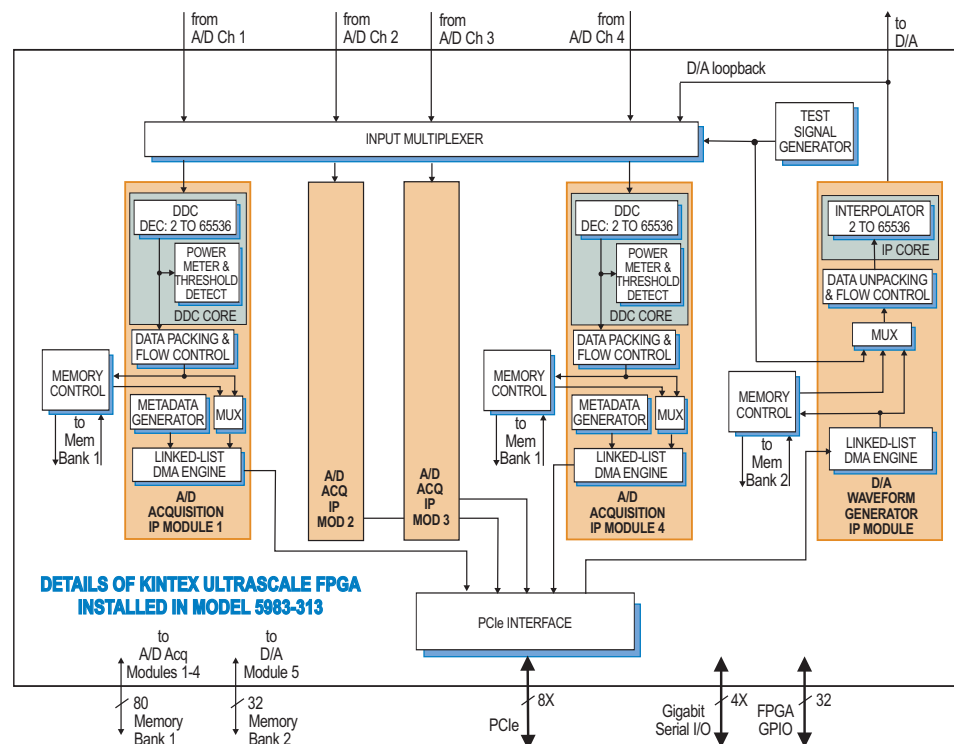

► The 5983-313 supports the VITA-66.4 standard, that provides up to 12 optical duplex lanes to the backplane. With the installation of a serial protocol, the VITA-66.4 interface enables gigabit backplane communications between boards independent of the PCIe interface.

GPS

An optional GPS receiver provides time and position information to the FPGA. This information can be used for precise data tagging.

A/D Converter Stage

The front end accepts four analog HF or IF inputs on front-panel connectors with transformer-coupling into two Texas Instruments ADS42LB69 dual 250 MHz, 16-bit A/D converters.

Digital Upconverter and D/A Stage

A TI DAC5688 DUC and D/A accepts a baseband real or complex data stream from the FPGA and provides that input to the upconvert, interpolate and D/A stages.

When operating as a DUC, it interpolates and translates real or complex baseband input signals to any IF center frequency from DC to the sampling frequency. It delivers the output to the 16-bit D/A converter. Analog outputs are through front panel connectors.

If translation is disabled, the DAC5688 acts as a dual interpolating 16-bit D/A with output sampling rates up to 800 MHz. In both modes the DAC5688 provides interpolation factors of 2x, 4x and 8x.

In addition, the FPGA-based interpolator provides a range of 2x to 65536x in two stages of 2x to 256x. Including the DAC5688 interpolation, the overall available interpolation range equals 2x to 524,288x.

Clocking and Synchronization

Two internal timing buses provide all timing and synchronization required by the A/D and D/A converters. Each includes a clock, sync and gate or trigger signals. An on-board clock generator receives an external sample clock from the front panel coaxial connector.

This clock can be used directly by the A/D or D/A sections or divided by a built-in clock synthesizer circuit to provide different A/D and D/A clocks. In an alternate mode, the sample clock can be sourced from an on-board programmable VCXO. In this mode, the front-panel coaxial connector can be used to

provide a 10 MHz reference clock for synchronizing the internal oscillator.

A front panel LVTTTL Gate/Trigger/Sync connector can receive an external timing signal to synchronize multiple modules.

PCI Express Interface

The Model 5983-313 includes an industry-standard interface fully compliant with PCI Express Gen. 1, 2 and 3 bus specifications. Supporting PCIe links up to x8, the interface includes multiple DMA controllers for efficient transfers to and from the board.

Memory Resources

The 5983-313 architecture supports two independent DDR3 SDRAM memory banks. The banks are four and five gigabytes each and are part of the board's DMA capabilities, providing FIFO memory space for creating DMA packets.

Specifications

Front Panel Analog Signal Inputs

Input Type: Transformer-coupled, front panel connectors

Transformer Type: Coil Craft WBC4-6TLB

Full Scale Input: +4 dBm into 50 ohms

3 dB Passband: 300 kHz to 700 MHz

A/D Converters

Type: Texas Instruments ADS42LB69

Sampling Rate: 10 MHz to 250 MHz

Resolution: 16 bits

4-Channel Digital Downconverter

Decimation Range: 2x to 65,536x in two stages of 2x to 256x

LO Tuning Freq. Resolution: 32 bits, 0 to f_s

LO SFDR: >120 dB

Phase Offset Resolution: 32 bits, 0 to 360 degrees

FIR Filter: 18-bit user-programmable coefficients, 24-bit output

Default Filter Set: 80% bandwidth, <0.3 dB passband ripple, >100 dB stopband attenuation

Phase Shift Coefficients: I & Q with 16-bit resolution

Gain Coefficients: 16-bit resolution ►

SPARK Development Systems

The Model 8267 is a fully-integrated development system for Pentek 3U VPX boards. It was created to save engineers and system integrators the time and expense associated with building and testing a development system that ensures optimum performance of Pentek boards.



Ordering Information

Model	Description
5983-313	4-Channel 250 MHz 16-bit A/D, with DDCs, 2-Channel 800 MHz 16-bit D/A with DUC, Extended Interpolation and Kintex Ultra-Scale FPGA - 3U VPX

Options:

-087	XCKU115-2 FPGA
-110	VITA-66.4 12X optical interface
-180	GPS Support
-702	Air cooled, Level L2
-763	Conduction-cooled, Level L3

Contact Pentek for availability of rugged and conduction-cooled versions

Model	Description
8267	VPX Development System See 8267 Datasheet for Options

► Specifications, Continued

D/A Converters

Type: Texas Instruments DAC5688
Input Data Rate: 250 MHz max.
Output IF: DC to 400 MHz max.
Output Sampling Rate: 800 MHz max. with interpolation
Resolution: 16 bits

Digital Interpolator

Interpolation Range: 2x to 65,536x in two stages of 2x to 256x

Total Interpolation Range

D/A and digital combined: 2x to 524,288x

Front Panel Analog Signal Outputs

Output Type: Transformer-coupled, front panel connector
Transformer Type: Coil Craft WBC4-6TLB

Full Scale Output: +4 dBm into 50 ohms

3 dB Passband: 300 kHz to 700 MHz

Sample Clock Sources: On-board clock synthesizer generates two clocks: an A/D clock and a D/A clock

Clock Synthesizer

Clock Source: Selectable from on-board programmable VCXO (10 to 810 MHz), front panel external clock or LVPECL timing bus
Synchronization: VCXO can be locked to an external 4 to 180 MHz PLL system reference, typically 10 MHz
Clock Dividers: External clock or VCXO can be divided by 1, 2, 4, 8 or 16 for the A/D clock

External Clock

Type: Front panel female SSMC connector, sine wave, 0 to +10 dBm, AC-coupled, 50 ohms, accepts 10 to 800 MHz divider input clock or PLL system reference

External Trigger Input

Type: Front panel connector
Function: Programmable functions include: trigger, gate, sync and PPS

Field Programmable Gate Array

Standard: Xilinx Kintex UltraScale XCKU060-2
Optional: Xilinx Kintex UltraScale XCKU115-2

Custom FPGA I/O

Serial: 4X gigabit links between the FPGA and the VPX P1 connector to support serial protocols.
Parallel: 16 pairs of LVDS connections between the FPGA and the VPX P2 connector for custom I/O
Optical (Option -110): VITA-66.4, 12X duplex lanes

Memory

Type: DDR4 SDRAM
Size: Two banks, one 4 GB and one 5 GB
Speed: 1200 MHz (2400 MHz DDR)

PCI-Express Interface

PCI Express Bus: Gen. 1, 2 or 3: x4 or x8;

Environmental

Standard: L0 (air cooled)

Operating Temp: 0° to 50° C
Storage Temp: -20° to 90° C
Relative Humidity: 0 to 95%, non-condensing

Option -702: L2 (air cooled)

Operating Temp: -20° to 65° C
Storage Temp: -40° to 100° C
Relative Humidity: 0 to 95%, non-condensing

Option -763: L3 (conduction cooled)

Operating Temp: -40° to 70° C
Storage Temp: -50° to 100° C
Relative Humidity: 0 to 95%, non-condensing

Size: 3.937 in. x 6.717 in. (100 mm x 170.6 mm)

OpenVPX Compatibility: The Model 5983-313 is compatible with the following module profile, as defined by the VITA 65 Open-VPX Specification:

SLT3-PAY-2F1F2U1E-14.6.6-1

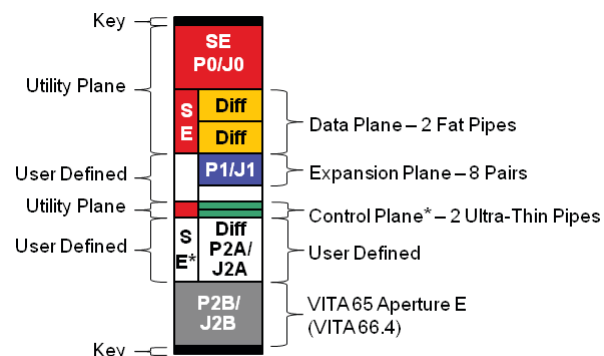

* not connected on board



Model 7070-312



Features

- Supports Xilinx Virtex-7 VXT FPGAs
- GateXpress supports dynamic FPGA reconfiguration across PCIe
- Four 250 MHz 16-bit A/Ds
- One digital upconverter
- Two 800 MHz 16-bit D/As
- 4 GB of DDR3 SDRAM
- Sample clock synchronization to an external system reference
- PCI Express (Gen. 1, 2 & 3) interface up to x8
- Optional optical interface for gigabit serial interboard communication
- Optional LVDS connections to the Virtex-7 FPGA for custom I/O

General Information

Model 7070-312 is a member of the Flexor® family of high-performance PCIe boards based on the Xilinx Virtex-7 FPGA.

As a FlexorSet™ integrated solution, the Model 3312 FMC is factory-installed on the 5973 FMC carrier. The required FPGA IP is installed and the board set is delivered ready for immediate use.

The delivered FlexorSet is a multichannel, high-speed data converter and is suitable for connection to the HF or IF ports of a communications or radar system. Its built-in data capture features offer an ideal turnkey solution as well as a platform for developing and deploying custom FPGA processing IP.

It includes four 250 MHz, 16-bit A/Ds, one digital upconverter, two 800 MHz, 16-bit D/As, and four banks of memory. In addition to supporting PCIe Gen. 3 as a native interface, the Model 7070-312 includes optional copper and optical connections to the Virtex-7 FPGA for custom I/O.

The Flexor Architecture

Based on the proven design of the Pentek Onyx family of Virtex-7 products, the 7070 FMC carrier retains all the key features of that family. As a central foundation of the board architecture, the FPGA has access to all data and control paths of both the carrier board and the FMC module, enabling factory-installed functions that include data multiplexing, channel selection, data packing, gating, triggering and memory control.

When delivered as an assembled board

set, the 7070-312 includes factory-installed applications ideally matched to the board's analog interfaces. The functions include four A/D acquisition IP modules for simplifying data capture and data transfer.

Each of the four acquisition IP modules contains IP modules for DDR3 SDRAM memories.

The 7070-312 features a sophisticated D/A waveform playback IP module. A linked-list controller allows users to easily play back to the D/As waveforms stored in either on-board or off-board host memory. Parameters including length of waveform, delay from playback trigger, waveform repetition, etc. can be programmed for each waveform.

Up to 64 individual link entries can be chained together to create complex waveforms with a minimum of programming.

A controller for all data clocking and synchronization functions, a test signal generator, and a PCIe interface complete the factory-installed functions and enable the 7070-312 to operate as a turnkey solution without the need to develop any FPGA IP.

Extendable IP Design

For applications that require specialized functions, users can install their own custom IP for data processing. Pentek GateFlow® FPGA Design Kits include all of the factory-installed modules as documented source code. Developers can integrate their own IP with the Pentek factory-installed functions or use the GateFlow kit to completely replace the Pentek IP with their own. ➤

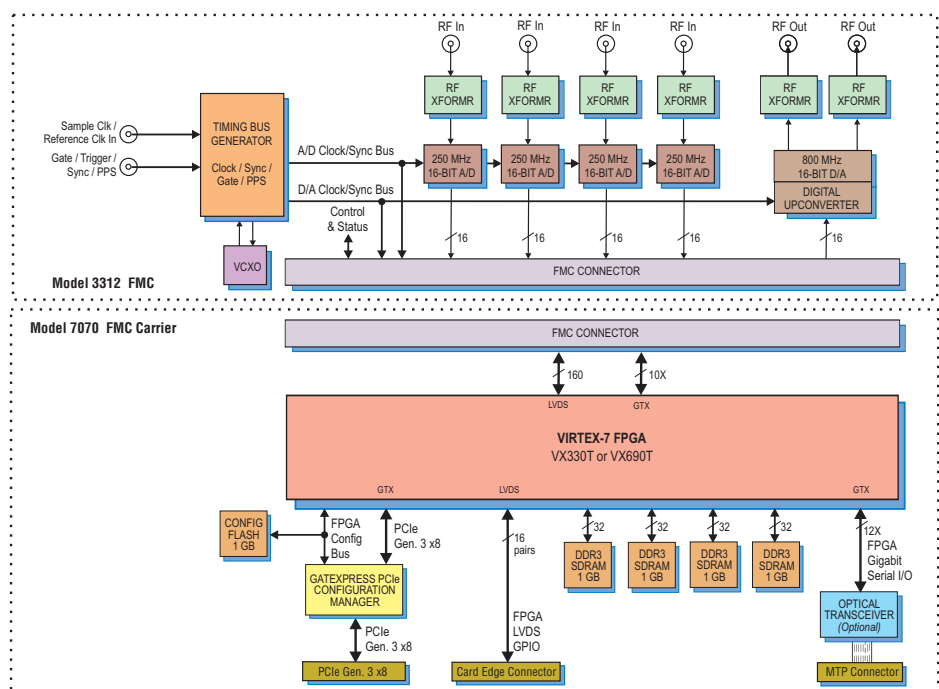

A/D Acquisition IP Modules

The 7070-312 features four A/D Acquisition IP Modules for easy capture and data moving. Each IP module can receive data from any of the four A/Ds, a test signal generator or from the D/A Waveform Playback IP Module in loopback mode.

Each IP module has an associated memory bank for buffering data in FIFO mode or for storing data in transient capture mode. All memory banks are supported with DMA engines for moving A/D data through the PCIe interface.

These powerful linked-list DMA engines are capable of a unique Acquisition Gate Driven mode. In this mode, the length of a transfer performed by a link definition need not be known prior to data acquisition; rather, it is governed by the length of the acquisition gate. This is extremely useful in applications where an external gate drives acquisition and the exact length of that gate is not known or is likely to vary.

For each transfer, the DMA engine can automatically construct metadata packets containing A/D channel ID, a sample accurate time stamp, and data length information. These actions simplify the host processor's job of identifying and executing on the data.

D/A Waveform Playback IP Module

The 7070-312 factory-installed functions include a sophisticated D/A Waveform Playback IP module. A linked-list controller allows users to easily playback waveforms stored in either on-board or off-board host memory to the dual D/As.

Parameters including length of waveform, delay from playback trigger, waveform repetition, etc. can be programmed for each waveform. Up to 64 individual link entries can be chained together to create complex waveforms with a minimum of programming.

Xilinx Virtex-7 FPGA

The 7070-312 can be optionally populated with one of two Virtex-7 FPGAs to match the specific requirements of the processing task. Supported FPGAs are VX330T or VX690T. The VX690T features 3600 DSP48E1 slices and is ideal for modulation/demodulation, encoding/decoding, encryption/decryption, and channelization of the signals between transmission and reception. For applications not requiring large DSP resources or logic, the lower-cost VX330T can be installed.

Option -104 provides 16 pairs of LVDS connections between the FPGA and a card-edge connector for custom I/O.

Option -110: For applications requiring optical gigabit links, up to 12 high-speed, full-duplex FPGA GTX lanes driven via an optical transceiver support serial protocols. A 12-lane MTP optical connector is presented on the PCIe slot panel.

GateXpress for FPGA Configuration

The Flexor architecture includes GateXpress®, a sophisticated FPGA-PCIe configuration manager for loading and reloading the FPGA. At power-up, GateXpress immediately presents a PCIe target for the host computer to discover, effectively giving the FPGA time to load from FLASH. This is especially important for larger FPGAs where the loading times can exceed the PCIe discovery window, typically 100 msec on many systems.

The board's configuration FLASH can hold four FPGA images. Images can be factory-installed IP or custom IP created by the user, and programmed into the FLASH via JTAG using Xilinx iMPACT or through the board's PCIe interface. At power-up the user can choose which image will load based on a hardware switch setting.

Once booted, GateXpress allows the user three options for dynamically reconfiguring the FPGA with a new IP image. The first option to load is an alternate image from FLASH through software control. The user selects the desired image and issues a reload command.

The second option is for applications where the FPGA image must be loaded directly through the PCIe interface. This is important in security situations where there can be no latent user image left in non-volatile memory when power is removed. In applications where the FPGA IP may need to change many times during the course of a mission, images can be stored on the host computer and loaded through PCIe as needed.

The third option, typically used during development, allows the user to directly load the FPGA through JTAG using Xilinx iMPACT.

In all three FPGA loading scenarios, GateXpress handles the hardware negotiation simplifying and streamlining the

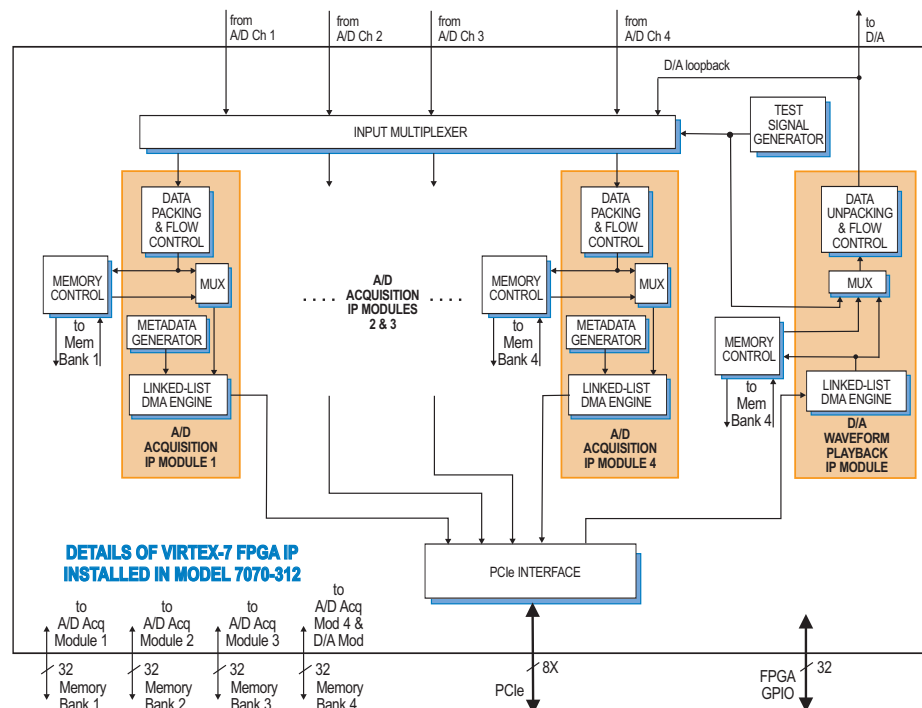

PCI Express Interface

The Model 7070-312 includes an industry-standard interface fully compliant with PCI Express Gen. 1, 2 and 3 bus specifications. Supporting PCIe links up to x8, the interface includes multiple DMA controllers for efficient transfers to and from the board.

Memory Resources

The 7070-312 architecture supports four independent DDR3 SDRAM memory banks. Each bank is 1 GB deep and is an integral part of the board's DMA capabilities, providing FIFO memory space for creating DMA packets.

SPARK Development Systems

The Model 8266 is a fully-integrated PC development system for Pentek PCI Express boards. It was created to save engineers and system integrators the time and expense associated with building and testing a development system that ensures optimum performance of Pentek boards.



Ordering Information

Model	Description
7070-312	4-Channel 250 MHz A/D, 2-Channel 800 MHz 16-bit D/A with Virtex-7 FPGA - x8 PCIe
Options:	
-076	XC7VX690T-2 FPGA
-104	LVDS FPGA I/O to card-edge connector
-110	12x gigabit serial optical I/O with XC7VX690T FPGA, 4x w. XC7VX330T

Model	Description
8266	PC Development System See 8266 Datasheet for Options

➤ loading task. In addition, GateXpress preserves the PCIe configuration space allowing dynamic FPGA reconfiguration without needing to reset the host computer to rediscover the board. After the reload, the host simply continues to see the board with the expected device ID.

A/D Converter Stage

The front end accepts four analog HF or IF inputs on front-panel connectors with transformer-coupling into two Texas Instruments ADS42LB69 dual 250 MHz, 16-bit A/D converters.

Digital Upconverter and D/A Stage

A TI DAC5688 DUC and D/A accepts a baseband real or complex data stream from the FPGA and provides that input to the upconvert, interpolate and D/A stages.

When operating as a DUC, it interpolates and translates real or complex baseband input signals to any IF center frequency up to 360 MHz. It delivers the output to the 16-bit D/A converter. Analog outputs are through front panel connectors.

If translation is disabled, the DAC5688 acts as a dual interpolating 16-bit D/A with output sampling rates up to 800 MHz. In both modes the DAC5688 provides interpolation factors of 2x, 4x and 8x.

Clocking and Synchronization

Two internal timing buses provide all timing and synchronization required by the A/D and D/A converters. Each includes a clock, sync and gate or trigger signals. An on-board clock generator receives an external sample clock from the front panel coaxial connector. This clock can be used directly by the A/D or D/A sections or divided by a built-in clock synthesizer circuit to provide different A/D and D/A clocks. In an alternate mode, the sample clock can be sourced from an on-board programmable VCXO. In this mode, the front coaxial panel connector can be used to provide a 10 MHz reference clock for synchronizing the internal oscillator.

A front panel LVTTTL Gate/Trigger/Sync connector can receive an external timing signal to synchronize multiple modules.

Specifications

Front Panel Analog Signal Inputs

Input Type: Transformer-coupled, front panel connectors

Transformer Type: Coil Craft WBC4-6TLB

Full Scale Input: +4 dBm into 50 ohms

3 dB Passband: 300 kHz to 700 MHz

A/D Converters

Type: Texas Instruments ADS42LB69

Sampling Rate: 10 MHz to 250 MHz

Resolution: 16 bits

D/A Converters

Type: Texas Instruments DAC5688

Input Data Rate: 250 MHz max.

Output IF: DC to 400 MHz max.

Output Sampling Rate: 800 MHz max. with interpolation

Resolution: 16 bits

Front Panel Analog Signal Outputs

Output Type: Transformer-coupled, front panel connector

Transformer Type: Coil Craft WBC4-6TLB

Full Scale Output: +4 dBm into 50 ohms

3 dB Passband: 300 kHz to 700 MHz

Sample Clock Sources: On-board clock synthesizer generates two clocks: an A/D clock and a D/A clock

Clock Synthesizer

Clock Source: Selectable from on-board programmable VCXO (10 to 810 MHz), front panel external clock or LVPECL timing bus

Synchronization: VCXO can be locked to an external 4 to 180 MHz PLL system reference, typically 10 MHz

Clock Dividers: External clock or VCXO can be divided by 1, 2, 4, 8 or 16 for the A/D clock

External Clock

Type: Front panel female SSMC connector, sine wave, 0 to +10 dBm, AC-coupled, 50 ohms, accepts 10 to 800 MHz divider input clock or PLL system reference

External Trigger Input

Type: Front panel connector

Function: Programmable functions include: trigger, gate, sync and PPS

Field Programmable Gate Array

Standard: Xilinx Virtex-7 XC7VX330T-2

Option -076: Xilinx Virtex-7 XC7VX690T-2

Custom FPGA I/O

Parallel (Option -104): 16 pairs of LVDS connections between the FPGA and a card-edge connector for custom I/O

Optical (Option -110): 12x gigabit serial optical I/O with XC7VX690T FPGA, 4x with XC7VX330T

Memory

Type: DDR3 SDRAM

Size: Four banks, 1 GB each

Speed: 800 MHz (1600 MHz DDR)

PCI-Express Interface

PCI Express Bus: Gen. 1, 2 or 3: x4 or x8;

Environmental: Level L1 & L2 air-cooled,

Size: 4.376 in. x 7.948 in (111.2 mm x 201.6 mm)

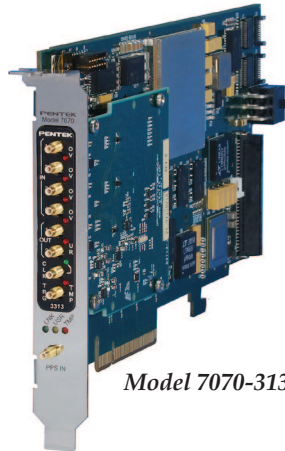

Model 7070-313



Features

- Supports Xilinx Virtex-7 VXT FPGAs
- GateXpress supports dynamic FPGA reconfiguration across PCIe
- Four 250 MHz 16-bit A/Ds
- Four multiband DDCs
- One digital upconverter
- Two 800 MHz 16-bit D/As
- Extended Interpolation
- 4 GB of DDR3 SDRAM
- Sample clock synchronization to an external system reference
- PCI Express (Gen. 1, 2 & 3) interface up to x8
- Optional optical Interface for gigabit serial interboard communication
- Optional LVDS connections to the Virtex-7 FPGA for custom I/O

General Information

Model 7070-313 is a member of the Flexor® family of high-performance PCIe boards based on the Xilinx Virtex-7 FPGA.

As a FlexorSet™ integrated solution, the Model 3312 FMC is factory-installed on the 7070 FMC carrier. The required FPGA IP is installed and the board-set is delivered ready for immediate use.

The delivered FlexorSet is a multichannel, high-speed data converter with programmable DDCs and is suitable for connection to HF or IF ports of a communications or radar system. Its built-in data capture and playback features offer an ideal turnkey solution as well as a platform for developing and deploying custom FPGA-processing IP.

The Model 7070-313 includes four 250 MHz, 16-bit A/Ds, one digital upconverter, two 800 MHz, 16-bit D/As, and four banks of memory. In addition to supporting PCIe Gen. 3 as a native interface, it includes optional copper and optical connections to the Virtex-7 FPGA for custom I/O.

The Flexor Architecture

Based on the proven design of the Pentek Onyx family of Virtex-7 products, the 7070 FMC carrier retains all the key features of that family. As a central foundation of the board architecture, the FPGA has access to all data and control paths of both the carrier board and the FMC module, enabling factory-installed functions that include data multiplexing, channel selection, data packing, gating, triggering and memory control.

When delivered as an assembled board set, the 7070-313 includes factory-installed applications ideally matched to the board's analog interfaces. The functions include four A/D acquisition IP modules for simplifying data capture and data transfer.

Each of the four acquisition IP modules contains a powerful DDC core.

The 7070-313 features a sophisticated D/A waveform playback IP module. A linked-list controller allows users to easily play back to the D/As waveforms stored in either on-board or off-board host memory. Parameters including length of waveform, delay from playback trigger, waveform repetition, etc. can be programmed for each waveform.

Up to 64 individual link entries can be chained together to create complex waveforms with a minimum of programming.

A controller for all data clocking and synchronization functions, a test signal generator, and a PCIe interface complete the factory-installed functions and enable the 7070-313 to operate as a turnkey solution without the need to develop any FPGA IP.

Extendable IP Design

For applications that require specialized functions, users can install their own custom IP for data processing. Pentek GateFlow® FPGA Design Kits include all of the factory-installed modules as documented source code. Developers can integrate their own IP with the Pentek factory-installed functions or use the GateFlow kit to completely replace the Pentek IP with their own. ➤

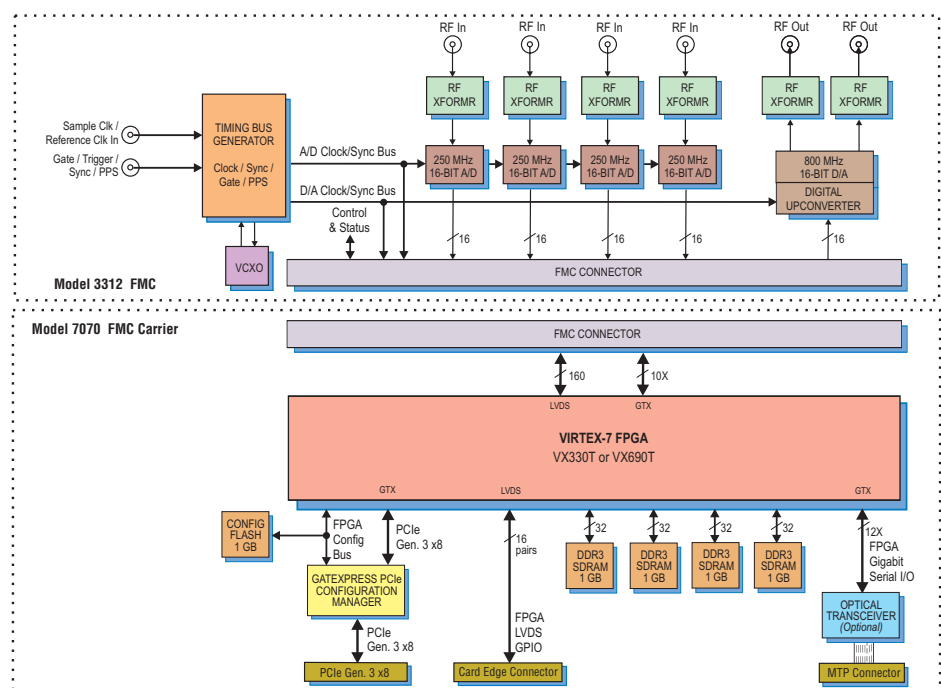

A/D Acquisition IP Modules

The 7070-313 features four A/D Acquisition IP Modules for easy capture and data moving. Each IP module can receive data from any of the four A/Ds, a test signal generator or from the D/A Waveform Playback IP Module in loopback mode.

Each IP module has an associated memory bank for buffering data in FIFO mode or for storing data in transient capture mode. All memory banks are supported with DMA engines for moving A/D data through the PCIe interface.

These powerful linked-list DMA engines are capable of a unique Acquisition Gate Driven mode. In this mode, the length of a transfer performed by a link definition need not be known prior to data acquisition; rather, it is governed by the length of the acquisition gate. This is extremely useful in applications where an external gate drives acquisition and the exact length of that gate is not known or is likely to vary.

For each transfer, the DMA engine can automatically construct metadata packets containing A/D channel ID, a sample accurate time stamp, and data length information. These actions simplify the host processor's job of identifying and executing on the data.

D/A Waveform Playback IP Module

The 7070-313 factory-installed functions include a sophisticated D/A Waveform Playback IP module. A linked-list controller allows users to easily playback waveforms stored in either on-board or off-board host memory to the dual D/As.

Parameters including length of waveform, delay from playback trigger, waveform repetition, etc. can be programmed for each waveform. Up to 64 individual link entries can be chained together to create complex waveforms with a minimum of programming.

DDC IP Cores

Within each A/D Acquisition IP Module is a powerful DDC IP core. Because of the flexible input routing of the A/D Acquisition IP Modules, many different configurations can be achieved including one A/D driving all four DDCs or each of the four A/Ds driving its own DDC.

Each DDC has an independent 32-bit tuning frequency setting that ranges from DC to f_s , where f_s is the A/D sampling frequency. Each DDC can have its own unique decimation setting, supporting as many as four different output bandwidths for the board. Decimations can be programmed from 2 to 65,536 providing a wide range to satisfy most applications.

The decimating filter for each DDC accepts a unique set of user-supplied 18-bit coefficients. The 80% default filters deliver an output bandwidth of $0.8 * f_s / N$, where N is the decimation setting. The rejection of adjacent-band components within the 80% output bandwidth is better than 100 dB. Each DDC delivers a complex output stream consisting of 24-bit I + 24-bit Q or 16-bit I + 16-bit Q samples at a rate of f_s / N .

Each DDC core contains programmable I & Q phase and gain adjustments followed by a power meter that continuously measures the individual average power output. The time constant of the averaging interval for each meter is programmable up to 8K samples. The power meters present average power

measurements for each DDC core output in easy-to-read registers.

In addition, each DDC core includes a threshold detector to automatically send an interrupt to the processor if the average power level of any DDC core falls below or exceeds a programmable threshold.

► Xilinx Virtex-7 FPGA

The 7070-313 can be optionally populated with one of two Virtex-7 FPGAs to match the specific requirements of the processing task. Supported FPGAs are VX330T or VX690T. The VX690T features 3600 DSP48E1 slices and is ideal for modulation/demodulation, encoding/decoding, encryption/decryption, and channelization of the signals between transmission and reception. For applications not requiring large DSP resources or logic, the lower-cost VX330T can be installed.

Option -104 provides 16 pairs of LVDS connections between the FPGA and a card-edge connector for custom I/O.

Option -110 supports the VITA-66.4 standard that provides 12 optical duplex lanes to the backplane. With the installation of a serial protocol, the VITA-66.4 interface enables gigabit backplane communications between boards independent of the PCIe interface. ►

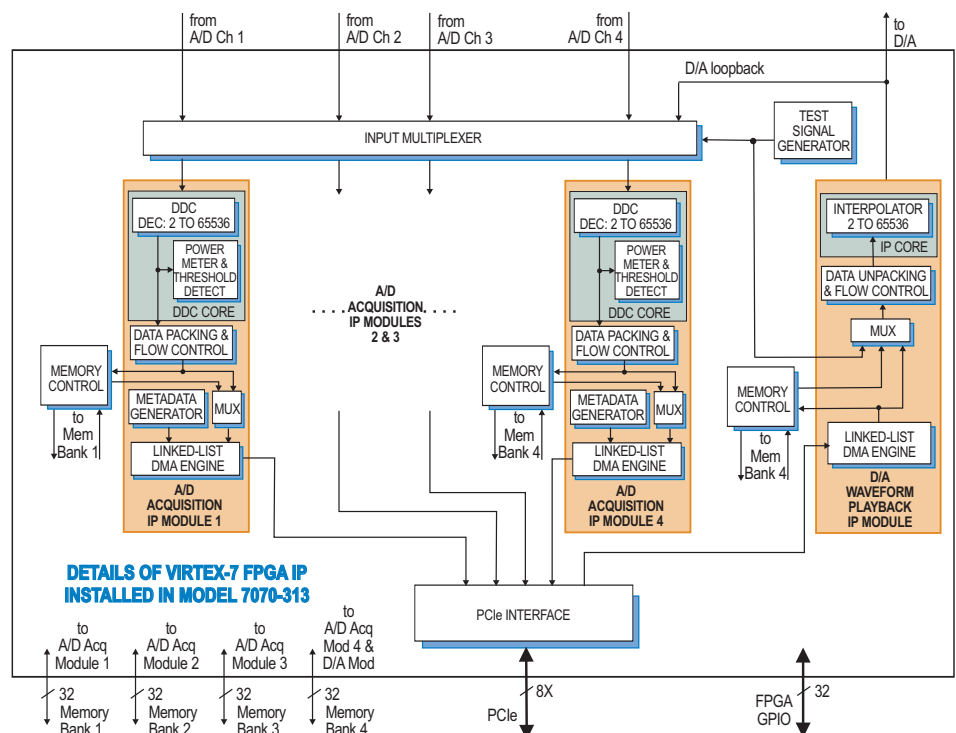

► GateXpress for FPGA Configuration

The Flexor architecture includes GateXpress®, a sophisticated FPGA-PCIe configuration manager for loading and reloading the FPGA. At power-up, GateXpress immediately presents a PCIe target for the host computer to discover, effectively giving the FPGA time to load from FLASH. This is especially important for larger FPGAs where the loading times can exceed the PCIe discovery window, typically 100 msec on many systems.

The board's configuration FLASH can hold four FPGA images. Images can be factory-installed IP or custom IP created by the user, and programmed into the FLASH via JTAG using Xilinx iMPACT or through the board's PCIe interface. At power-up the user can choose which image will load based on a hardware switch setting.

Once booted, GateXpress allows the user three options for dynamically reconfiguring the FPGA with a new IP image. The first option to load is an alternate image from FLASH through software control. The user selects the desired image and issues a reload command.

The second option is for applications where the FPGA image must be loaded directly through the PCIe interface. This is important in security situations where there can be no latent user image left in non-volatile memory when power is removed. In applications where the FPGA IP may need to change many times during the course of a mission, images can be stored on the host computer and loaded through PCIe as needed.

The third option, typically used during development, allows the user to directly load the FPGA through JTAG using Xilinx iMPACT. In all three FPGA loading scenarios, GateXpress handles the hardware negotiation simplifying and streamlining the loading task. In addition, GateXpress preserves the PCIe configuration space allowing dynamic FPGA reconfiguration without needing to reset the host computer to rediscover the board. After the reload, the host simply continues to see the board with the expected device ID.

A/D Converter Stage

The front end accepts four analog HF or IF inputs on front-panel connectors with transformer-coupling into two Texas Instruments ADS42LB69 dual 250 MHz, 16-bit A/D converters.

Digital Upconverter and D/A Stage

A TI DAC5688 DUC and D/A accepts a baseband real or complex data stream from the FPGA and provides that input to the upconvert, interpolate and D/A stages.

When operating as a DUC, it interpolates and translates real or complex baseband input signals to any IF center frequency up to 360 MHz. It delivers the output to the 16-bit D/A converter. Analog outputs are through front panel connectors.

If translation is disabled, the DAC5688 acts as a dual interpolating 16-bit D/A with output sampling rates up to 800 MHz. In both modes the DAC5688 provides interpolation factors of 2x, 4x and 8x.

In addition, the FPGA-based interpolator provides a range of 2x to 65536x in two stages of 2x to 256x. Including the DAC5688 interpolation, the overall available interpolation range equals 2x to 524,288x.

Clocking and Synchronization

Two internal timing buses provide all timing and synchronization required by the A/D and D/A converters. Each includes a clock, sync and gate or trigger signals. An on-board clock generator receives an external sample clock from the front panel coaxial connector.

This clock can be used directly by the A/D or D/A sections or divided by a built-in clock synthesizer circuit to provide different A/D and D/A clocks. In an alternate mode, the sample clock can be sourced from an on-board programmable VCXO. In this mode, the front-panel coaxial connector can be used to provide a 10 MHz reference clock for synchronizing the internal oscillator.

A front panel LVTTTL Gate/Trigger/Sync connector can receive an external timing signal to synchronize multiple modules. ►

SPARK Development Systems

The Model 8266 is a fully-integrated PC development system for Pentek PCI Express boards. It was created to save engineers and system integrators the time and expense associated with building and testing a development system that ensures optimum performance of Pentek boards.



Ordering Information

Model	Description
5973-313	4-Channel 250 MHz 16-bit A/D, with DDCs, 2-Channel 800 MHz 16-bit D/A with DUC, Extended Interpolation and Virtex-7 FPGA -x8 PCIe

Options:

-076	XC7VX690T-2 FPGA
-104	LVDS FPGA I/O between the FPGA and a card-edge connector for custom I/O
-110	VITA-66.4 12X optical I/O with XC7VX690T FPGA, 4X w. XC7VX330T

Model	Description
8266	PC Development System See 8266 Datasheet for Options

► PCI Express Interface

The Model 7070-313 includes an industry-standard interface fully compliant with PCI Express Gen. 1, 2 and 3 bus specifications. Supporting PCIe links up to x8, the interface includes multiple DMA controllers for efficient transfers to and from the board.

Memory Resources

The 7070-313 architecture supports four independent DDR3 SDRAM memory banks. Each bank is 1 GB deep and is an integral part of the board's DMA capabilities, providing FIFO memory space for creating DMA packets.

Specifications

Front Panel Analog Signal Inputs

- Input Type:** Transformer-coupled, front panel connectors
- Transformer Type:** Coil Craft WBC4-6TLB
- Full Scale Input:** +4 dBm into 50 ohms
- 3 dB Passband:** 300 kHz to 700 MHz

A/D Converters

- Type:** Texas Instruments ADS42LB69
- Sampling Rate:** 10 MHz to 250 MHz
- Resolution:** 16 bits

4-Channel Digital Downconverter

- Decimation Range:** 2x to 65,536x in two stages of 2x to 256x
- LO Tuning Freq. Resolution:** 32 bits, 0 to f_s
- LO SFDR:** >120 dB
- Phase Offset Resolution:** 32 bits, 0 to 360 degrees
- FIR Filter:** 18-bit user-programmable coefficients, 24-bit output
- Default Filter Set:** 80% bandwidth, <0.3 dB passband ripple, >100 dB stopband attenuation
- Phase Shift Coefficients:** I & Q with 16-bit resolution
- Gain Coefficients:** 16-bit resolution

D/A Converters

- Type:** Texas Instruments DAC5688
- Input Data Rate:** 250 MHz max.
- Output IF:** DC to 400 MHz max.
- Output Sampling Rate:** 800 MHz max. with interpolation
- Resolution:** 16 bits

Digital Interpolator

- Interpolation Range:** 2x to 65,536x in two stages of 2x to 256x

Total Interpolation Range

- D/A and digital combined: 2x to 524,288x

Front Panel Analog Signal Outputs

- Output Type:** Transformer-coupled, front panel connector
- Transformer Type:** Coil Craft WBC4-6TLB
- Full Scale Output:** +4 dBm into 50 ohms
- 3 dB Passband:** 300 kHz to 700 MHz

Sample Clock Sources: On-board clock synthesizer generates two clocks: an A/D clock and a D/A clock

Clock Synthesizer

Clock Source: Selectable from on-board programmable VCXO (10 to 810 MHz), front panel external clock or LVPECL timing bus

Synchronization: VCXO can be locked to an external 4 to 180 MHz PLL system reference, typically 10 MHz

Clock Dividers: External clock or VCXO can be divided by 1, 2, 4, 8 or 16 for the A/D clock

External Clock

Type: Front panel female SSMC connector, sine wave, 0 to +10 dBm, AC-coupled, 50 ohms, accepts 10 to 800 MHz divider input clock or PLL system reference

External Trigger Input

Type: Front panel connector
Function: Programmable functions include: trigger, gate, sync and PPS

Field Programmable Gate Array

Standard: Xilinx Virtex-7 XC7VX330T-2
Option -076: Xilinx Virtex-7 XC7VX690T-2

Custom FPGA I/O

Parallel (Option -104): 16 pairs of LVDS connections between the FPGA and a card-edge connector for custom I/O
Optical (Option -110): 12x gigabit serial optical I/O with XC7VX690T FPGA, 4x with XC7VX330T

Memory

Type: DDR3 SDRAM
Size: Four banks, 1 GB each
Speed: 800 MHz (1600 MHz DDR)

PCI-Express Interface

PCI Express Bus: Gen. 1, 2 or 3: x4 or x8;
Environmental: Level L1 & L2 air-cooled
Size: 4.376 in. x 7.948 in (111.2 mm x 201.6 mm)

Features

- Supports the Xilinx Virtex-7 FPGA
- Complete development environment with Pentek’s reference design
- Supports the Pentek Model 3312 FMC I/O Module

Pentek offers the option -990 reference design with software and IP support for the Pentek Model 3312 when installed on the Xilinx VC707 Evaluation Kit board.

The Virtex®-7 FPGA VC707 Evaluation Kit is a PCIe platform using the Virtex-7 XC7VX485T-2FFG1761C. It includes basic components of hardware, design tools, IP, and preverified reference designs.

When coupled with Pentek’s option -990 reference design for the 3312, the user has a complete development environment for custom applications. The industry-standard FPGA Mezzanine Connectors (FMC) are directly compatible with the 3312.

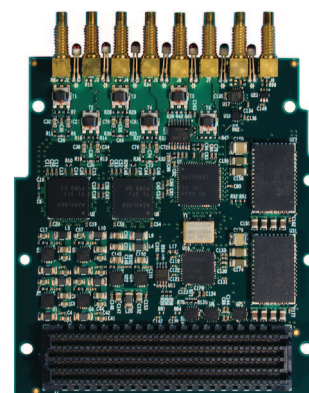
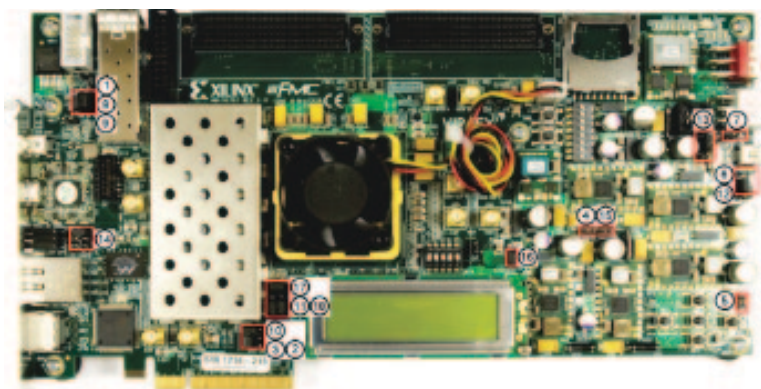

The Xilinx Virtex® -7 FPGA VC707 Evaluation Kit gives designers an easy starting point for evaluating and leveraging devices that deliver breakthrough performance, capacity, and power efficiency. Out of the box, this platform speeds time to market for the full-range of Virtex-7 FPGA-based applications including advanced systems for wired and wireless communications, aerospace and defense. The highly flexible kit combines fully integrated hardware, software, and IP with preverified reference designs that maximize productivity and let designers immediately focus on their unique project requirements.

The Flexor® Model 3312 is a multichannel, high-speed data converter FMC module. It includes four 250 MHz, 16-bit A/Ds, two 800 MHz, 16-bit D/As, programmable clocking, and multiboard synchronization for support of larger high-channel-count systems.

Ordering Information

Model	Description
3312-990	Reference Design for the Xilinx VC707 Evaluation Kit

Please purchase the Xilinx VC707 Evaluation Kit from your Xilinx authorized distributor:
<https://www.xilinx.com/products/boards-and-kits/ek-v7-vc707-g.html>