

**Pentek, Inc.**

One Park Way, Upper Saddle River, NJ 07458

Tel: (201) 818-5900 • Fax: (201) 818-5904

email: pipeline@pentek.com

http://www.pentek.com

© 2011 Pentek, Inc. Newsletter Editor: TNT Resources, LLC.  
 Trademarks are properties of their respective owners.  
 Specifications are subject to change without notice.

# The Pentek Pipeline

*A quarterly publication for engineering system design and applications.*

**In This Issue**

- Beamforming is a signal processing technique that utilizes an array of sensors to achieve directionality, increase the strength of transmitted signals and improve the quality of received signals. More in the feature article.

*"The Pentek Model 53661 Software Radio Board is a 3U OpenVPX Cobalt board ideally suited to beamforming applications. It's available in commercial and rugged versions up to and including conduction-cooled."*

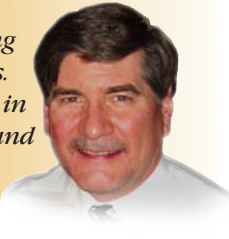

Rodger Hosking, Pentek Vice President and Co-founder

- **Product Focus:**  
[New Cobalt Recorder](#)

**Free Technical Resources**

- [Sign up for free subscription to The Pentek Pipeline](#)
- [Sign up for Virtex-6 Cobalt product updates](#)
- [Sign up for OpenVPX product updates](#)
- 2010 edition of the [High-Speed Switched Serial Fabrics Handbook](#)
- 2010 edition of the [SDR Handbook](#)
- 2010 edition of the [FPGAs for Software Radio Systems Handbook](#)
- 2010 edition of the [High-Speed A/Ds Handbook](#)

**8-Channel OpenVPX Beamforming System**

Beamforming is a signal processing technique that utilizes an array of sensors to achieve directionality, increase the strength of transmitted signals and improve the quality of received signals. Beamforming is extensively used in communications, radar, direction finding, countermeasures, weapons systems, oil and mineral exploration, and medical imaging and treatment.

Examples of software radio applications that use beamforming include direction finding. Here, the beamformed antenna can be steered to locate the arrival angle of a signal source. Two or more arrays can be used to triangulate the exact location of the source. This is essential for many signal intelligence and counter terrorism efforts.

**Principles of Beamforming**

Beamforming is typically used with an array of sensors or antennas to improve receptivity in a specific direction, for example, from a single cell phone as shown in Figure 1. The signal from a given source arrives at each antenna based on the distance between the source and the antenna, so the antenna signals have relative phase and amplitude offsets.

The beamforming process adjusts the gain and phase of each antenna signal to compensate for the different delays and signal paths. These adjustments align signals at each antenna for signals arriving from one particular direction. When the signals are summed together, the non-aligned signals arriving from other directions cancel each other while the signals from the beamformed direction add constructively for greatly improved signal-to-noise ratio. In this way, by electronically adjusting the gain and phase in each path, the antenna is effectively steered for directionality.

**System Block Diagram**

In this system, eight antennas are arranged in a linear array, and the overall block diagram is shown in Figure 2 on the next page. The antenna frequency is 2.5 GHz, so each antenna signal needs to be amplified, filtered and then downconverted to an IF frequency so it can be digitized by an A/D converter. Synchronous sampling across all eight channels is mandatory to preserve a fixed phase relationship for beamforming.

Samples from each A/D are downconverted to baseband complex I+Q signals in a DDC (digital downconverter), which also includes ▶

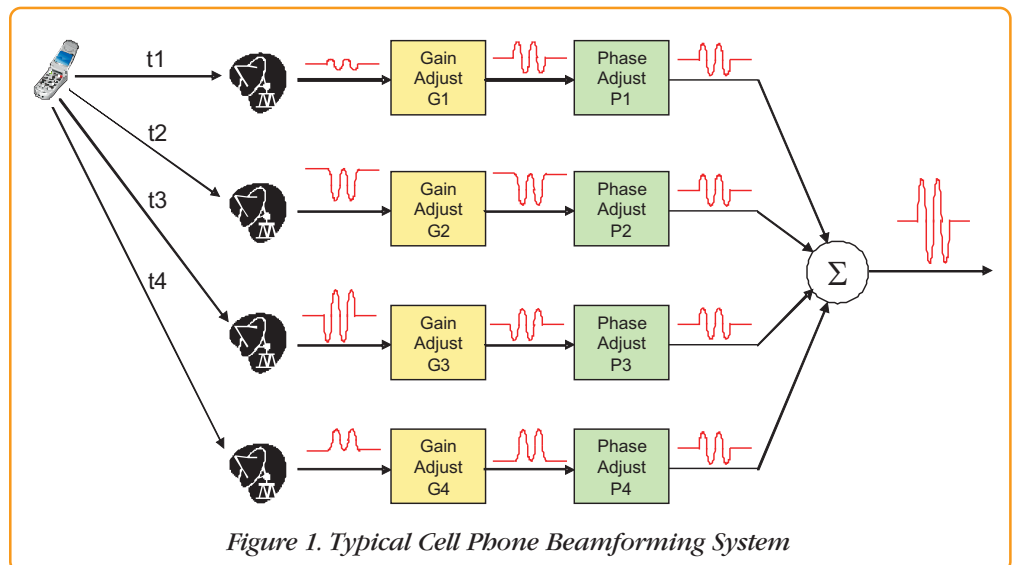

Figure 1. Typical Cell Phone Beamforming System

## 8-Channel OpenVPX Beamforming System

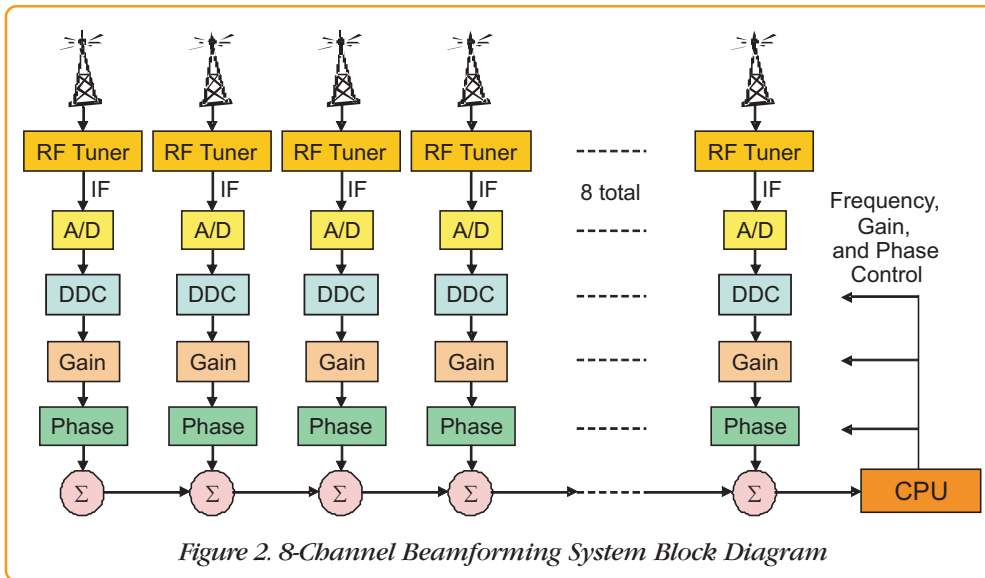

Figure 2. 8-Channel Beamforming System Block Diagram

► channel-specific phase and gain adjustments for the beamforming “weights”. All eight baseband signals are then added together in summation blocks to produce the final beamformed sum signal. A CPU analyzes the sum and makes adjustments to the phase and gain coefficients to track or adapt to new targets.

### Model 53661 Beamforming Board

The Model 53661 Software Radio board is a 3U OpenVPX Cobalt® board shown in the simplified block diagram of Figure 3. It features four 200 MHz 16-bit A/D converters, a timing, clock and synchronization section, and a Xilinx Virtex-6 FPGA. Factory-installed in the FPGA, are four DDC IP cores, each capable of accepting A/D samples from any of the four A/Ds. Each DDC has a decimation range of 2 to 64K and can deliver downconverted baseband bandwidths from 2.5 kHz to 80 MHz. Each DDC has programmable gain and phase shift controls accessible to the processor across the VPX backplane. In this system we will be assigning one A/D to each DDC.

At the output of each DDC is a power meter (not shown) that calculates the downconverted signal power. Each power meter is equipped with a threshold detector that generates a system interrupt if the output power exceeds the upper threshold or falls below the lower threshold. These features simplify gain calibration and signal monitoring tasks that otherwise would

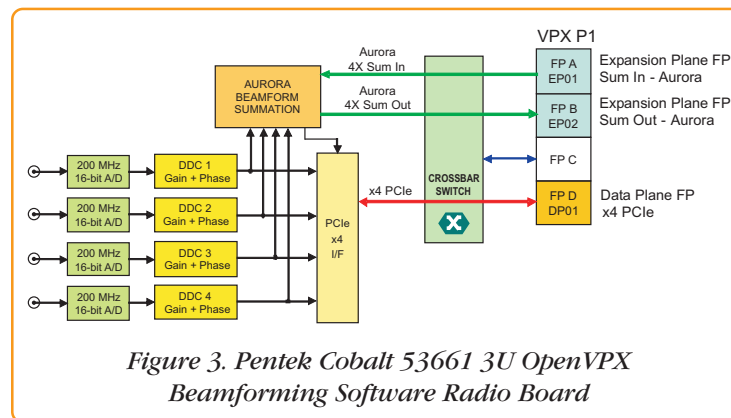

Figure 3. Pentek Cobalt 53661 3U OpenVPX Beamforming Software Radio Board

have to be done in software by the system processor.

The 53661 FPGA also includes an Aurora summation block that adds the four DDC outputs together to perform the channel combining for beamforming. Aurora is a lightweight link-layer gigabit serial protocol for Xilinx FPGAs. In this board, the Aurora interface accepts a propagated sum on one 4X input port and delivers the new propagated sum on a 4X output port including the contributions from the four on-board channels. Operating at a bit rate of 3.125 Gbits/sec, each 4X link can transfer data at 1.25 GBytes/sec.

A PCIe x4 interface operating at 2.5 Gbit/sec serial clock rate provides a 1 GByte/sec link to the control processor for programming DDC and beamforming parameters. This PCIe link also supports delivery of the four DDC outputs as well as the beamforming summation output.

A programmable gigabit serial crossbar switch connects the two 4X Aurora summation links and the x4 PCIe link to the VPX P1 backplane connector. The flexibility of this crossbar switch allows the 53661 to operate in a variety of OpenVPX backplane topologies and slot profiles. In this system the Aurora links are mapped onto the OpenVPX Expansion Plane and the PCIe interface is mapped onto the OpenVPX Data Plane, which also assumes the role of Control Plane.

The Pentek Model 53661 Cobalt board shown in Figure 4 is available in commercial air-cooled as well as conduction-cooled versions. ►



Figure 4. The Pentek Cobalt 53661 is Available in COTS and Rugged Versions

## 8-Channel OpenVPX Beamforming System

### ► 8-Channel 3U OpenVPX System

The complete 8-channel OpenVPX beamforming system is shown in Figure 5. Two Model 53661 boards are installed in slots 1 and 2 of an OpenVPX backplane, along with a CPU board in slot 3. Eight dipole antennas designed for receiving 2.5 GHz signals feed RF Tuners containing low noise amplifiers, local oscillators and mixers. The RF Tuners translate the 2.5 GHz antenna frequency signal down to an IF frequency of 50 MHz.

The 200 MHz 16-bit A/D converters digitize the IF signals and perform further frequency downconversion to baseband, with a DDC decimation of 128. This provides I+Q complex output samples with a bandwidth of about 1.25 MHz. Phase and gain coefficients for each channel are applied to steer the array for directionality.

The CPU board in VPX slot 3 sends commands and coefficients across the backplane over two x4 PCIe links, or OpenVPX “fat pipes”.

The first four signal channels are processed in the upper left 53661 board in VPX slot 1, where the 4-channel beamformed sum is propagated through the 4X Aurora Sum Out link across the backplane to the 4X Aurora Sum In port on the second 53661 in slot 2. The 4-channel local summation from the second 53661 is added to the propagated sum from the first board to form the complete 8-channel sum. This final sum is sent across the x4 PCIe link to the CPU card in slot 3.

Assignment of the three OpenVPX 4X links (OpenVPX fat pipes) on the Model 53661 boards is simplified through the use of the crossbar switch shown in the previous block diagram. This allows the 53661 to operate with a wide variety of different backplanes.

Because OpenVPX does not restrict the use of serial protocols across the backplane links, mixed protocol architectures like the one shown are fully supported.

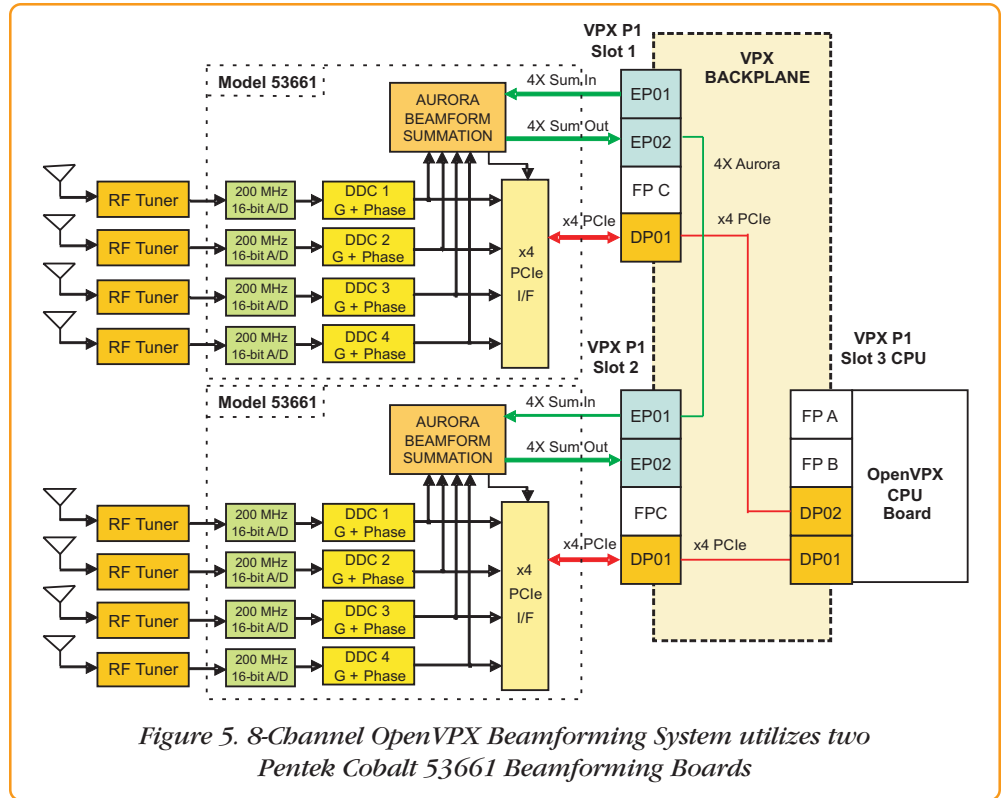

Figure 5. 8-Channel OpenVPX Beamforming System utilizes two Pentek Cobalt 53661 Beamforming Boards

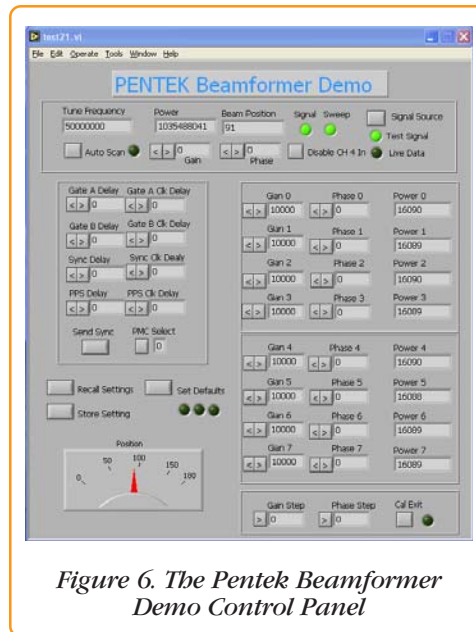

Figure 6. The Pentek Beamformer Demo Control Panel

### Beamforming Demo System

As shown in Figure 6, the beamforming demo system is equipped with a control panel that runs under Windows® on the CPU board. It includes an automatic signal scanner to detect the strongest signal frequency arriving from a test transmitter. This frequency is centered around the 50 MHz IF frequency of the RF downconverter. Once the frequency is identified, the eight DDCs are set accordingly to bring that signal down to 0 Hz for summation.

The control panel software also allows specific hardware settings for all of the parameters for the eight channels including gain, phase, and sync delay. ►

## 8-Channel OpenVPX Beamforming System

► An additional display shows the beam-formed pattern of the array. This display is formed by adjusting the phase shift of each of the eight channels to provide maximum sensitivity across arrival angles from  $-90^{\circ}$  to  $+90^{\circ}$  perpendicular to the plane of the array.

The classic 7-lobe pattern for an ideal 8-element array for a signal arriving at  $0^{\circ}$  angle (directly in front of the array) is shown in Figure 7. Below the lobe pattern is a polar plot showing a single vector pointing to the computed angle of arrival. This is derived from identifying the lobe with the maximum response.

An actual plot of a real-life transmitter is shown in Figure 8 for a source directly in front of the display. In this case the perfect lobe pattern is affected by physical objects, reflections, cable length variations and minor differences in the antennas.

Nevertheless, the directional information is computed quite well. As the signal source is moved left and right in front of the array, the peak lobe moves with it, changing the computed angle of arrival.

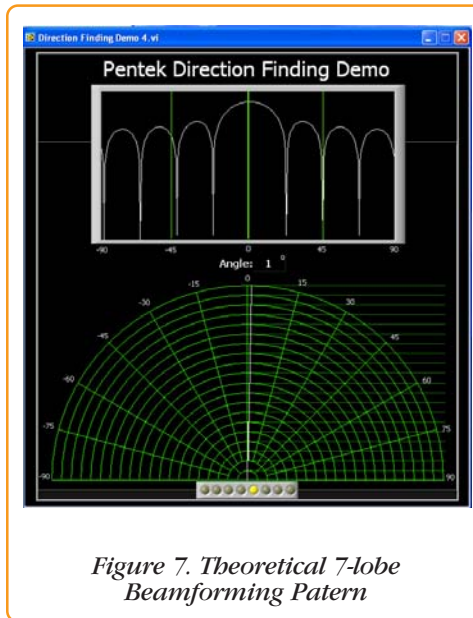

Figure 7. Theoretical 7-lobe Beamforming Pattern

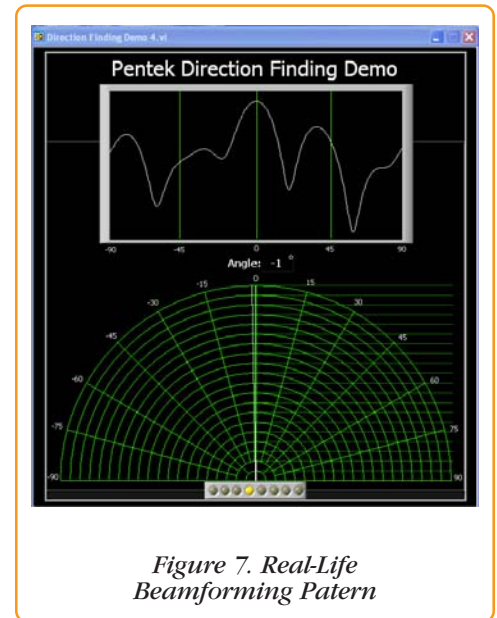

Figure 7. Real-Life Beamforming Pattern

This demo system is available online at Pentek. If you are interested in viewing a live demonstration, please let us know of

your interest by clicking on this link: [Beamforming Demo](#) □



### Cobalt Bundle Includes:

- Cobalt Virtex-6 board available in XMC, PCI Express or OpenVPX formats
- ReadyFlow® board support libraries for Windows, Linux or VxWorks
- Time and frequency domain signal analyzer utility
- Command-line interface
- Operating manuals and documentation
- Complete cable kit
- Lifetime product support
- Online technical resources with automatic alerts for updates and new releases

### It's Up to You!

#### Simply Choose:

- Any Cobalt Virtex-6 product
- Form factor: XMC, or PCIe, or OpenVPX
- Board support package OS: Windows, Linux, or VxWorks

## Limited-Time Bundle Offer!

■ Save \$2,500 ■



### Cobalt Product Features:

- A/D and D/A sampling rates from 10 MHz to 1 GHz
- Dedicated DMA channels and memory buffers for each I/O stream
- Multiboard synchronization
- ReadyFlow board support libraries
- GateFlow® FPGA Design Kit and installed IP cores
- Complete solutions for wireless communications, radar, SIGINT, and beamforming



### Cobalt Virtex-6 FPGA Boards:

- [Model 71630 - XMC](#)  
1 GHz A/D and 1 GHz D/A
- [Model 53650 - VPX](#)  
2-Channel 500 MHz A/D, DUC, and 2-Channel 800 MHz D/A
- [Model 78620 - PCIe](#)  
3-Channel 200 MHz A/D, DUC, and 2-Channel 800 MHz D/A
- [Model 71621 - XMC](#)  
3-Channel 200 MHz A/D, DDC, DUC, and 2-Channel 800 MHz D/A
- [Model 78660 - PCIe](#)  
4-Channel 200 MHz 16-bit A/D
- [Model 53661 - VPX](#)  
4-Channel 200 MHz 16-bit A/D and four DDCs with beamforming IP
- [Model 78662 - PCIe](#)  
4-Channel 200 MHz 16-bit A/D and 32 DDC channels
- [Model 71690 - XMC](#)  
L-Band (925–2175 MHz) Tuner with 2-Channel 200 MHz A/D

For a list of all Cobalt products [Click Here](#)

# Product Focus

## Model RTS 2706

## Real-Time Data Recording and Playback Instrument

### Offers COTS Configurations with Customizable Features



The Pentek RTS 2706 is a turnkey, multiband recording and playback instrument for recording and reproducing high-bandwidth signals. The RTS 2706 uses 16-bit, 200 MHz A/D converters and provides sustained recording rates up to 1600 MB/sec in four-channel configuration. Using Pentek's high-powered Virtex-6-based Cobalt modules, it offers flexibility in channel count, with optional downconversion capabilities. Optional 16-bit, 800 MHz D/A converters with upconversion allow real-time reproduction of recorded signals.

A/D sampling rates, DDC decimations and bandwidths, D/A sampling rates, and DUC interpolations are among the GUI-selectable system parameters, providing a fully programmable instrument capable of recording and reproducing a wide range of signals.

Optional GPS time and position stamping allows the user to record this critical signal information.

### SystemFlow Software

The RTS 2706 includes the System-Flow® Recording Software. SystemFlow features

### Features

- Complete multiband recording and playback instrument
- 4U 19 inch industrial rack-mount PC server chassis
- Windows® 7 Professional workstation with high-performance Intel® Core™ i7 processor
- 16-bit 200 MHz A/Ds
- 16-bit 800 MHz D/As

a Windows-based GUI (graphical user interface) that provides a simple means to configure and control the instrument. Custom configurations can be stored as profiles and later loaded when needed, allowing the user to select preconfigured settings with a single click.

SystemFlow also includes signal viewing and analysis tools, that allow the user to monitor the signal prior to, during, and after a recording session. These tools include a virtual oscilloscope and a virtual spectrum analyzer.

- Real-time sustained recording rates of up to 1600 MB/sec
- Configurations from one to eight channels of recording and playback
- From 2 to 20 terabytes storage to NTFS RAID disk array
- RAID levels of 0, 1, 5, 6, 10 and 50
- SystemFlow® GUI with Signal Viewer analysis tool
- File headers include time stamping and recording parameters
- Optional DDC decimation and DUC interpolation range from 2 to 65,536
- Up to 80 MHz record and playback signal bandwidths
- IF frequencies to 700 MHz
- Optional GPS time and position stamping

Built on a Windows 7 Professional workstation, the RTS 2706 allows the user to install post processing and analysis tools to operate on the recorded data. The instrument records data to the native NTFS file system, providing immediate access to the recorded data.

### SystemFlow Signal Viewer

The SystemFlow Signal Viewer includes a virtual oscilloscope and spectrum analyzer for signal monitoring in both the time and frequency domains. It is extremely useful for previewing live inputs prior to recording, and for monitoring signals as they are being recorded to help ensure successful recording sessions. The viewer can also be used to inspect and analyze the recorded files after the recording is complete.

Advanced signal analysis capabilities include automatic calculators for signal amplitude and frequency, second and third harmonic components, THD (total harmonic distortion) and SINAD (signal to noise and distortion). With time and frequency zoom, panning modes, and dual annotated cursors to mark and measure points of interest, the SystemFlow Signal Viewer can often eliminate the need for a separate oscilloscope or spectrum analyzer in the field. For more information click: [Model RTS 2706](#)

