



**Features**

- Complete radar and software radio interface solution
- Supports Xilinx Virtex-6 LXT and SXT FPGAs
- Two 500 MHz 12-bit A/Ds
- One digital upconverter
- Two 800 MHz 16-bit D/As
- Up to 2 GB of DDR3 SDRAM or 32 MB of QDRII+ SRAM
- Sample clock synchronization to an external system reference
- LVPECL clock/sync bus for multiboard synchronization
- PCI Express (Gen. 2) interface up to x8
- Optional user-configurable gigabit serial interface
- Optional LVDS connections to the Virtex-6 FPGA for custom I/O

**General Information**

Model 78650 is a member of the Cobalt® family of high performance PCIe boards based on the Xilinx Virtex-6 FPGA. A multi-channel, high-speed data converter, it is suitable for connection to HF or IF ports of a communications or radar system. Its built-in data capture and playback features offer an ideal turnkey solution.

It includes two A/Ds, one DUC (Digital Upconverter), two D/As, and four banks of memory. In addition to supporting PCI Express Gen. 2 as a native interface, the Model 78650 includes optional general-purpose and gigabit serial card connectors for application specific I/O protocols.

**The Cobalt Architecture**

The Pentek Cobalt architecture features a Virtex-6 FPGA. All of the board's data and control paths are accessible by the FPGA, enabling factory installed functions including data multiplexing, channel selection, data packing, gating, triggering and memory control. The Cobalt architecture organizes the FPGA as a container for data processing applications where each function exists as an intellectual property (IP) module.

Each member of the Cobalt family is delivered with factory installed applications ideally matched to the board's analog interfaces. The 78650 factory-installed functions include two A/D acquisition and one D/A waveform playback IP modules. In addition, IP modules for either DDR3 or QDRII+ memories, a controller for all data clocking and synchronization functions, a test signal generator and a PCIe interface complete

the factory-installed functions and enable the 78650 to operate as a complete turnkey solution, without the need to develop any FPGA IP.

**Extendable IP Design**

For applications that require specialized functions, users can install their own custom IP for data processing. Pentek GateFlow FPGA Design Kits include all of the factory installed modules as documented source code. Developers can integrate their own IP with the Pentek factory-installed functions or use the GateFlow Design Kit to completely replace the Pentek IP with their own.

**Xilinx Virtex-6 FPGA**

The Virtex-6 FPGA site can be populated with a variety of different FPGAs to match the specific requirements of the processing task. Supported FPGAs include: LX130T, LX240T, or SX315T. The SXT part features 1344 DSP48E slices and is ideal for modulation/demodulation, encoding/decoding, encryption/decryption, and channelization of the signals between transmission and reception. For applications not requiring large DSP resources, one of the lower-cost LXT FPGAs can be installed.

Option -104 connects 20 pairs of LVDS signals from the FPGA on PMC P14 to a 68-pin DIL ribbon-cable header on the PCIe board for custom I/O.

Option -105 connects two 4X gigabit serial links from the FPGA on XMC P16 to two 4X gigabit serial connectors along the top edge of the PCIe board. ➤

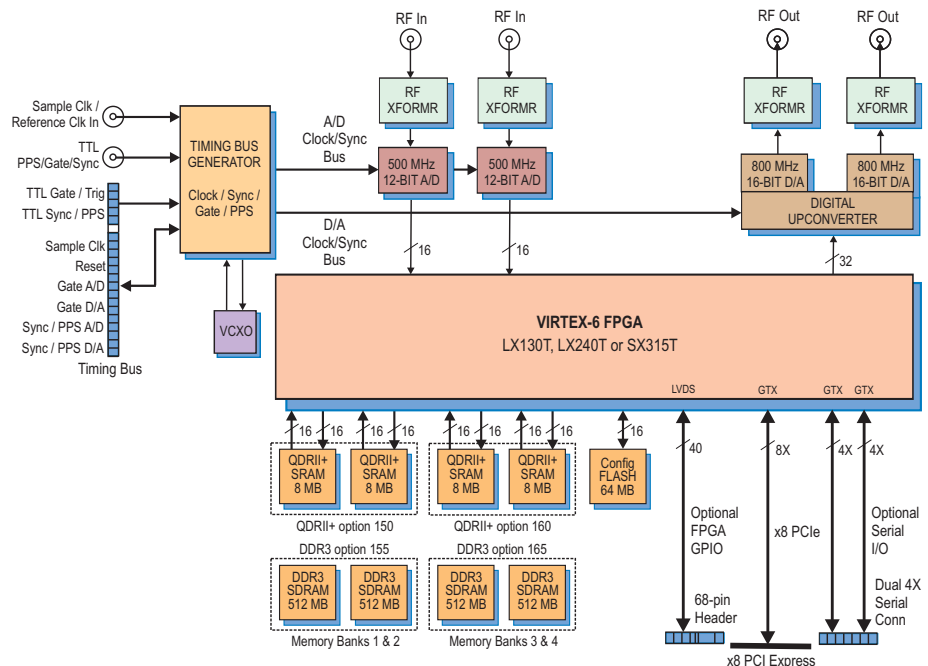

**A/D Acquisition IP Modules**

The 78650 features two A/D Acquisition IP Modules for easy capture and data moving. Each IP module can receive data from either of the two A/Ds, a test signal generator or from the D/A Waveform Playback IP Module in loopback mode. Each IP module has an associated memory bank for buffering data in FIFO mode or for storing data in transient capture mode. All memory banks are supported with DMA engines for moving A/D data through the PCIe interface.

These powerful linked-list DMA engines are capable of a unique Acquisition Gate Driven mode. In this mode, the length of a transfer performed by a link definition need not be known prior to data acquisition; rather, it is governed by the length of the acquisition gate. This is extremely useful in applications where an external gate drives acquisition and the exact length of that gate is not known or is likely to vary.

For each transfers, the DMA engine can automatically construct metadata packets containing A/D channel ID, a sample-accurate time stamp, and data length information. These actions simplify the host processor's job of identifying and executing on the data.

**D/A Waveform Playback IP Module**

The Model 78650 factory-installed functions include a sophisticated D/A Waveform Playback IP module. A linked-list controller allows users to easily play back waveforms stored in either on-board memory or off-board host memory to the dual D/As.

Parameters including length of waveform, delay from playback trigger, waveform repetition, etc. can be programmed for each waveform. Up to 64 individual link entries can be chained together to create complex waveforms with a minimum of programming.

**A/D Converter Stage**

The front end accepts two full scale analog HF or IF inputs on front panel SSMC connectors at +5 dBm into 50 ohms with transformer coupling into two Texas Instruments ADS5463 500 MHz, 12-bit A/D converters.

The digital outputs are delivered into the Virtex-6 FPGA for signal processing, data capture or for routing to other board resources.

**Digital Upconverter and D/A Stage**

A TI DAC5688 DUC and D/A accepts a baseband real or complex data stream from the FPGA and provides that input to the upconvert, interpolate and dual D/A stages.

When operating as a DUC, it interpolates and translates real or complex baseband input signals to any IF center frequency up to 360 MHz. It delivers real or quadrature (I+Q) analog outputs to the dual 16-bit D/A converter. Analog output is through a pair of front panel SSMC connectors.

If translation is disabled, the DAC5688 acts as a dual interpolating 16-bit D/A with output sampling rates up to 800 MHz. In both modes the DAC5688 provides interpolation factors of 2x, 4x and 8x.

**Clocking and Synchronization**

Two internal timing buses provide either a single clock or two different clock rates to the A/D and D/A signal paths.

Each timing bus includes a clock, sync and a gate or trigger signal. An on-board clock generator receives an external sample clock from the front panel SSMC connector. This clock can be used directly for either the A/D or D/A sections or can be divided by a built-in clock synthesizer circuit to provide different A/D and D/A clocks. In an alternate mode, the sample clock can be sourced from an onboard programmable voltage-controlled crystal oscillator. In this mode, the front panel SSMC connector can be used to provide a 10 MHz reference clock for synchronizing the internal oscillator.

A front panel 26-pin LVPECL Clock/Sync connector allows multiple boards to be synchronized. In the slave mode, it accepts LVPECL inputs that drive the clock, sync and gate signals. In the master mode, the LVPECL bus can drive the timing signals for synchronizing multiple boards.

Multiple 78650's can be driven from the LVPECL bus master, supporting synchronous sampling and sync functions across all connected boards.

**Memory Resources**

The 78650 architecture supports up to four independent memory banks which can be configured with all QDRII+ SRAM, DDR3 SDRAM, or as combination of two banks of each type of memory.

Each QDRII+ SRAM bank can be up to 8 MB deep and is an integral part of the

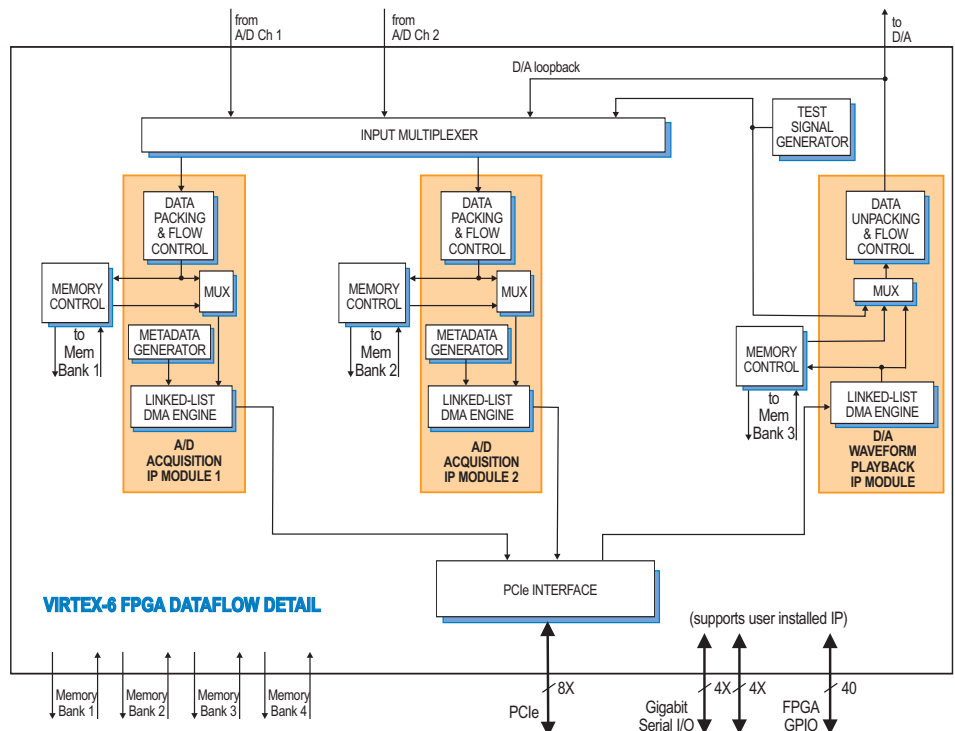

## Model 8266

The Model 8266 is a fully-integrated PC development system for Pentek Cobalt, Onyx and Flexor PCI Express boards. It was created to save engineers and system integrators the time and expense associated with building and testing a development system that ensures optimum performance of Pentek boards.



## Ordering Information

| Model           | Description                                                              |
|-----------------|--------------------------------------------------------------------------|
| 78650           | Two 500 MHz A/Ds, one DUC, two 800 MHz D/As with Virtex-6 FPGA - x8 PCIe |
| <b>Options:</b> |                                                                          |
| -002*           | -2 FPGA speed grade                                                      |
| -014            | 400 MHz, 14-bit A/Ds                                                     |
| -062            | XC6VLX240T FPGA                                                          |
| -064            | XC6VSX315T FPGA                                                          |
| -104            | LVDS FPGA I/O through 68-pin ribbon cable connector                      |
| -105            | Gigabit serial FPGA I/O through two 4X top edge connectors               |
| -150            | Two 8 MB QDRII+ SRAM Memory Banks (Banks 1 and 2)                        |
| -160            | Two 8 MB QDRII+ SRAM Memory Banks (Banks 3 and 4)                        |
| -155            | Two 512 MB DDR3 SDRAM Memory Banks (Banks 1 and 2)                       |
| -165            | Two 512 MB DDR3 SDRAM Memory Banks (Banks 3 and 4)                       |

\* This option is always required

| Model | Description                                          |
|-------|------------------------------------------------------|
| 8266  | PC Development System See 8266 Datasheet for Options |

► board's DMA capabilities, providing FIFO memory space for creating DMA packets. For applications requiring deep memory resources, DDR3 SDRAM banks can each be up to 512 MB deep. Built-in memory functions include an A/D data transient capture mode and D/A waveform playback mode.

In addition to the factory-installed functions, custom user-installed IP within the FPGA can take advantage of the memories for many other purposes.

## PCI Express Interface

The Model 78650 includes an industry-standard interface fully compliant with PCI Express Gen. 1 & 2 bus specifications. Supporting PCIe links up to x8, the interface includes multiple DMA controllers for efficient transfers to and from the board.

## Specifications

### Front Panel Analog Signal Inputs

**Input Type:** Transformer-coupled, front panel female SSMC connectors

**Transformer Type:** Coil Craft WBC4-6TLB

**Full Scale Input:** +5 dBm into 50 ohms

**3 dB Passband:** 300 kHz to 700 MHz

### A/D Converters (standard)

**Type:** Texas Instruments ADS5463

**Sampling Rate:** 20 MHz to 500 MHz

**Resolution:** 12 bits

### A/D Converters (option 014)

**Type:** Texas Instruments ADS5474

**Sampling Rate:** 20 MHz to 400 MHz

**Resolution:** 14 bits

### D/A Converters

**Type:** Texas Instruments DAC5688

**Input Data Rate:** 250 MHz, max.

**Output IF:** DC to 400 MHz, max.

**Output Signal:** 2-channel real or 1-channel with frequency translation

**Output Sampling Rate:** 800 MHz, max. with interpolation

**Resolution:** 16 bits

### Front Panel Analog Signal Outputs

**Output Type:** Transformer-coupled, front panel female SSMC connectors

**Transformer Type:** Coil Craft WBC4-6TLB

**Full Scale Output:** +4 dBm into 50 ohms

**3 dB Passband:** 300 kHz to 700 MHz

**Sample Clock Sources:** On-board clock synthesizer generates two clocks: one A/D clock and one D/A clock

## Clock Synthesizer

**Clock Source:** Selectable from on-board programmable VCXO (10 to 810 MHz), front panel external clock or LVPECL timing bus

**Synchronization:** VCXO can be locked to an external 4 to 180 MHz PLL system reference, typically 10 MHz

**Clock Dividers:** External clock or VCXO can be divided by 1, 2, 4, 8, or 16, independently for the A/D clock and D/A clock

## External Clock

**Type:** Front panel female SSMC connector, sine wave, 0 to +10 dBm, AC-coupled, 50 ohms, accepts 10 to 800 MHz divider input clock or PLL system reference

**Timing Bus:** 26-pin front panel connector LVPECL bus includes, clock/sync/gate/PPS inputs and outputs; TTL signal for gate/trigger and sync/PPS inputs

## External Trigger Input

**Type:** Front panel female SSMC connector, LVTTTL

**Function:** Programmable functions include: trigger, gate, sync and PPS

## Field Programmable Gate Array

**Standard:** Xilinx Virtex-6 XC6VLX130T-2

**Optional:** Xilinx Virtex-6 XC6VLX240T-2 or XC6VSX315T-2

## Custom I/O

**Option -104:** Connects 20 pairs of LVDS signals from the FPGA on PMC P14 to a 68-pin DIL ribbon-cable header on the PCIe board for custom I/O.

**Option -105:** Connects two 4X gigabit serial links from the FPGA on XMC P16 to two 4X gigabit serial connectors along the top edge of the PCIe board

## Memory

**Option 150 or 160:** Two 8 MB QDRII+ SRAM memory banks, 400 MHz DDR

**Option 155 or 165:** Two 512 MB DDR3 SDRAM memory banks, 400 MHz DDR

## PCI-Express Interface

**PCI Express Bus:** Gen.1: x4 or x8  
Gen. 2: x4

## Environmental

**Operating Temp:** 0° to 50° C

**Storage Temp:** -20° to 90° C

**Relative Humidity:** 0 to 95%, non-cond.

**Size:** Half length PCIe card, 4.38 in. x 7.13 in.