



Model 7340-420

Model 7240D-420



Features

- GateFlow Core 420, two high-performance wideband DDCs and interpolation filter, factory-installed
- Extended DDC decimation range of 2 to 1,048,576
- Extended DDC bandwidth range of 40 MHz to 76.3 Hz
- Extended DUC interpolation range of 2 to 32,768
- Extended DUC bandwidth range of 40 MHz to 2.44 kHz

General Information

Models 7240-420 and 7340-420 are cPCI Transceivers with Dual Wideband DDCs and Interpolation Filters. They consist of one Model 7140-420 transceiver mounted on a cPCI carrier board. Model 7240-420 is a 6U cPCI board, while the Model 7340-420 is a 3U cPCI board. Model 7240D-420 is the same as the Model 7240-420, except it contains two 7140-420's rather than one.

The receiver section features two or four AD6645 105 MHz 14-bit A/D converters and one or two TI GC4016 quad multiband digital downconverter. The digital outputs of the A/Ds are delivered to the Virtex-II Pro FPGAs and to other module resources including the GC4016 which supports a decimation range from 32 to 16,384. For an A/D sample clock frequency of 100 MHz, the output bandwidth for each of the four channels ranges from 2.5 MHz down to 5 kHz. By combining two or four channels, decimations of 16 or 8 can be achieved for an output bandwidth of up to 5 or 10 MHz, respectively.

For applications that require even wider bandwidths, these boards include Pentek's GateFlow Installed Core 420 high-performance wideband DDC, similar in functionality to the GC1012 but with enhanced performance, and an interpolation filter that extends the range of the DAC5686 D/A converter.

Core 420 Wideband Downconverter

Like the GC4016, the Core 420 down-converter translates any frequency band within the input bandwidth range down to zero frequency. A complex FIR low pass filter then removes any out of band frequency components. An output decimator and formatter deliver output data in either real or complex representation.

An input gain block scales both I and Q data streams by a 16-bit gain term. The NCO provides over 118 dB spurious-free dynamic range (SFDR).

The mixer utilizes four 18x18-bit multipliers to handle the complex inputs from the NCO and the complex data input samples. The FIR filter is capable of storing and utilizing up to four independent sets of 18-bit coefficients for each decimation value. These coefficients are user-programmable using RAM structures within the FPGA.

Two identical Core 420 DDCs are factory installed in the FPGA. The decimation settings of 2, 4, 8, 16, 32, and 64 provide output bandwidths from 40 MHz down to 1.25 MHz for an A/D sampling rate of 100 MHz. It also delivers better stopband rejection than the GC4016 in combined channel modes.

A multiplexer in front of the Core 420 DDCs allows data to be sourced from either the A/D converters or from the output of the GC4016, extending the maximum cascaded decimation factor to 1,048,576.

Core 420 Interpolation Filter

The interpolation filter included in the 420 Core, expands the interpolation factor from 2 to 32,768 programmable in steps of 2, and relieves the host processor from performing upsampling tasks. Including the DUC, the maximum interpolation factor is 32,768 which is comparable to the maximum decimation of the GC4016 narrowband DDC.

In addition to the Core 420, all the standard features of these Models are retained including D/A waveform generator mode, all data routing and formatting, and delay and transient capture memory. ➤

Model 7240-420 and 7340-420 Block Diagram Model 7240-420D doubles all resources except the PCI Bridge

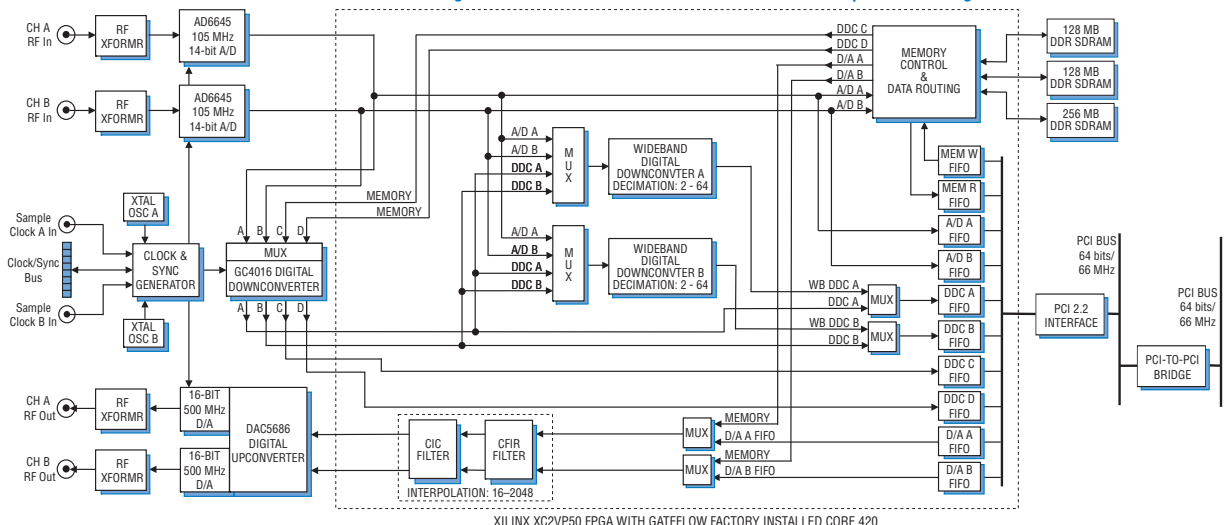

► Clocking and Synchronization

Two independent internal timing buses can provide either a single clock or two different clock rates for the input and output signals.

Each timing bus includes a clock, a sync, and a gate or trigger signal. Signals from either Timing Bus A or B can be selected as the timing source for the A/Ds, the downconverters, the upconverters and the D/As. Two external reference clocks are accepted, one for each timing bus and two internal clocks may be used for each timing bus.

Front panel 26-pin LVDS Clock/Sync connectors allow multiple boards to be synchronized. In the slave mode, they accept differential LVDS inputs that drive the clock, sync and gate signals for the two internal timing buses.

In the master mode, the LVDS bus can drive one or both sets of timing signals from the two internal timing buses for synchronizing multiple modules.

Up to four slave 7240D-420's or seven 7240-420's or 7340-420's can be driven from the LVDS bus master, supporting synchronous sampling and sync functions across all connected boards. Up to eighty 7240-420 or 7340-420 boards, or forty 7240D-420 boards may be synchronized with a Model 9190 Clock and Sync Generator.

Memory Resources

Three independent banks of SDRAM are available to each FPGA. Built-in memory functions include an A/D data transient capture mode with pre- and post-triggering; a D/A waveform generator mode; and an A/D data delay mode for applications like tracking receivers. User-installed functions within the FPGA can take advantage of the SDRAM for many other purposes.

PCI Interface

An industry-standard interface fully compliant with PCI 2.2 bus specifications is included. The interface includes nine separate DMA controllers for efficient transfers to and from the module.

Data widths of 32 or 64 bits and data rates of 33 or 66 MHz are supported.

Specifications

7240-420: Dual Configuration; 7240D-420: Quad Configuration; 7340-420: Dual Configuration

7240D-420 shown in the Specifications Front Panel Analog Signal Inputs (4)

Input Type: Transformer-coupled, front panel female MMCX connectors

Transformer Type: Mini-Circuits ADT4-5WT

Full Scale Input: +4 dBm into 50 ohms

3 dB Passband: 300 kHz to 270 MHz

A/D Converters (4)

Type: Analog Devices AD6645-105

Sampling Rate: 30 MHz to 105 MHz

Internal Clock: Crystal oscillator A or B

External Clock: 30 to 105 MHz

Resolution: 14 bits

Digital Downconverters (2)

Type: TI/Graychip GC4016

Decimation: 32 to 16,384; with channel combining mode: 8 or 16

Data Source: A/D, FPGA, or PCI interface

Control Source: FPGA or PCI interface

Output: Parallel complex data

Receiver Bypass Mode:

Data from the A/Ds can be written directly into the FPGAs at a rate equal to the A/D clock decimated by any integer between 1 and 4096

Front Panel Analog Signal Outputs (4)

Output Type: Transformer-coupled, front panel female MMCX connectors

Full Scale Output: +4 dBm into 50 ohms

3 dB Passband: 60 kHz to 300 MHz

Digital Upconverters (2)

Type: TI DAC5686

Input Bandwidth: 40 MHz, max.

Output IF: DC to 160 MHz

Output Signal: Analog, real or quadrature

Sampling Rate: 320 MHz, max; 500 MHz max. with upconversion disabled

Resolution: 16 bits

Clock Sources (4):

Selectable from onboard A or B crystal oscillators, external or LVDS clocks

External Clocks (4)

Type: Front panel MMCX connectors, sine wave, 0 to +10 dBm, AC-coupled, 50 ohms

Sync/Gate Bus (2):

26-pin connector, dual clock/sync/gate input/output LVDS buses; one sync/gate input TTL signal

Field Programmable Gate Array (2)

Type: Xilinx XC2VP50 Virtex-II Pro

Memory

DDR SDRAM: 1 GB in six banks

FLASH: 32 MB in two banks

PCI Interface

PCI Bus: 64-bit, 66 MHz (also supports 32-bit and/or 33 MHz)

Local Bus: 64-bit, 66 MHz

DMA: 9 channel demand-mode and chaining controller

Environmental

Operating Temp: 0° to 50° C

Storage Temp: -20° to 90° C

Relative Humidity: 0 to 95%, non-cond.

Size: Standard 6U cPCI board

Ordering Information

Model	Description
7240-420	GateFlow Transceiver with two Wideband DDCs and Interpolation Filter factory-installed - 6U cPCI
7240D-420	GateFlow Transceiver with four Wideband DDCs and two Interpolation Filters factory-installed - 6U cPCI
7340	GateFlow Transceiver with two Wideband DDCs and Interpolation Filter factory-installed - 3U cPCI

Contact Pentek for available options