



General Information

Model 71611 is a member of the Cobalt® family of high performance XMC modules based on the Xilinx Virtex-6 FPGA. A multi-channel, gigabit serial interface, it is ideal for interfacing to Serial FPDP data converter boards or as a chassis-to-chassis data link.

The 71611 is fully compatible with the VITA 17.1 Serial FPDP specification. Its built-in data transfer features make it a complete turnkey solution. For users who require application-specific functions, the 71611 serves as a flexible platform for developing and deploying custom FPGA processing IP.

In addition to supporting PCI Express as a native interface, the Model 71611 includes a general purpose connector for application-specific I/O.

The Cobalt Architecture

The Pentek Cobalt Architecture features a Virtex-6 FPGA. All of the board's data and control paths are accessible by the FPGA, enabling factory-installed functions including data transfer and memory control. The Cobalt Architecture organizes the FPGA as a container for data processing applications where each function exists as an intellectual property (IP) module.

IP modules for DDR3 SDRAM memories, controllers for data routing and flow control,

CRC support, advanced DMA engines, and a PCIe interface complete the factory-installed functions and enable the 71611 to operate as a complete turnkey solution without the need to develop any FPGA IP.

Extendable IP Design

For applications that require specialized functions, users can install their own custom IP for data processing. Pentek GateFlow® FPGA Design Kits include all of the factory-installed modules as documented source code. Developers can integrate their own IP with the Pentek factory-installed functions or use the GateFlow kit to completely replace the Pentek IP with their own.

Xilinx Virtex-6 FPGA

The Virtex-6 FPGA site can be populated with a variety of different FPGAs to match the specific requirements of the processing task. Supported FPGAs include: LX240T, SX315T, or SX475T. The SXT parts feature up to 2016 DSP48E slices and are ideal for modulation/demodulation, encoding/decoding, encryption/decryption, and channelization of the signals between transmission and reception. For applications not requiring large DSP resources, the lower-cost LXT FPGA can be installed.

Option -104 installs the P14 PMC connector with 20 pairs of LVDS connections to the FPGA for custom I/O. ➤

Features

- Complete Serial FPDP solution
- Fully compliant with VITA 17.1 specification
- Fiber optic or copper serial interfaces
- Up to 2 GB of DDR3 SDRAM
- PCI Express interface up to x8
- LVDS connections to the Virtex-6 FPGA for custom I/O

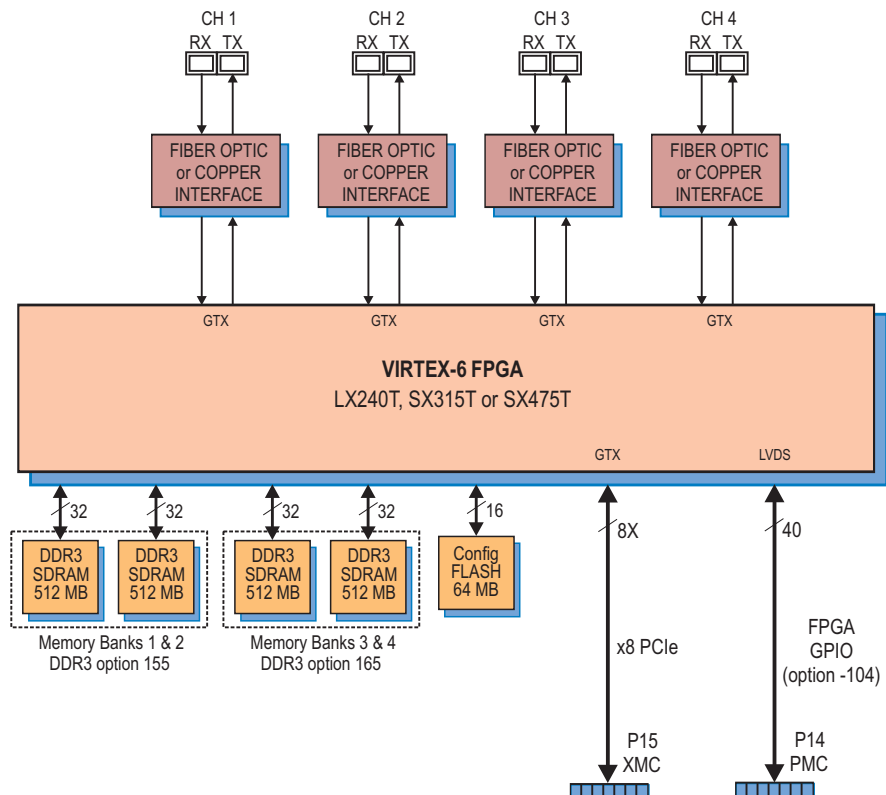

Model 8266

The Model 8266 is a fully-integrated PC development system for Pentek Cobalt, Onyx and Flexor PCI Express boards. It was created to save engineers and system integrators the time and expense associated with building and testing a development system that ensures optimum performance of Pentek boards.



Ordering Information

Model	Description
71611	Quad Serial FPDP Interface with Virtex-6 FPGA - XMC

Options:

-062	XC6VLX240T FPGA
-064	XC6VSX315T FPGA
-065	XC6VSX475T FPGA
-104	LVDS FPGA I/O through P14 connector
-155	Two 512 MB DDR3 SDRAM Memory Banks (Banks 1 and 2)
-165	Two 512 MB DDR3 SDRAM Memory Banks (Banks 3 and 4)
-280	Copper serial interfaces
-281	Multi-mode optical serial interfaces

Contact Pentek for availability of rugged and conduction-cooled versions

Model	Description
8266	PC Development System See 8266 Datasheet for Options

Serial FPDP Interface

The 71611 is fully compatible with the VITA 17.1 Serial FPDP specification. With the capability to support 1.0625, 2.125, 2.5, 3.125, and 4.25 Gbaud link rates and the option for multi-mode and single-mode optical interfaces, the board can work in virtually any system. Programmable modes include: flow control in both receive and transmit directions, CRC support, and copy/loop modes.

Memory Resources

The 71611 architecture supports up to four independent memory banks of DDR3 SDRAM. Each memory is 512 MB deep and an integral part of the module's DMA capabilities, providing FIFO memory space for creating DMA packets.

In addition to the factory-installed functions, custom user-installed IP within the FPGA can take advantage of the memories for many other purposes.

PCI Express Interface

The Model 71611 includes an industry-standard interface fully compliant with PCI Express Gen. 1 bus specifications. Supporting PCIe links up to x8, the interface includes eight DMA controllers. Each of the four Serial FPDP channels includes dedicated DMA engines for transmit and receive for efficient transfers to and from the module.

Specifications

Front Panel Serial FPDP Inputs/Outputs

Number of Connectors: 4

Fiber Optic Connector Type: LC

Laser: 850 nm (standard, other options available)

Copper Connector Type: Micro Twinax

Fiber Optic or Copper Link Rates:

1.0625, 2.125, 2.5, 3.125 or 4.25 Gbaud (copper rate depends on cable length)

Fiber Optic or Copper Data Transfer Rates: 105, 210, 247, 309 or 420 MB/sec

(depending on link rate) per serial FPDP port

Field Programmable Gate Array: Xilinx

Virtex-6 XC6VLX240T, XC6VSX315T, or XC6VSX475T

Custom I/O

Option -104: Installs the PMC P14 connector with 20 LVDS pairs to the FPGA

Memory

Option 155 or 165: Two 512 MB DDR3 SDRAM memory banks, 400 MHz DDR

PCI-Express Interface

PCI Express Bus: Gen. 1: x4 or x8

Environmental

Operating Temp: 0° to 50° C

Storage Temp: -20° to 90° C

Relative Humidity: 0 to 95%, non-cond.

Size: Standard XMC module, 2.91 in. x 5.87 in. ➤

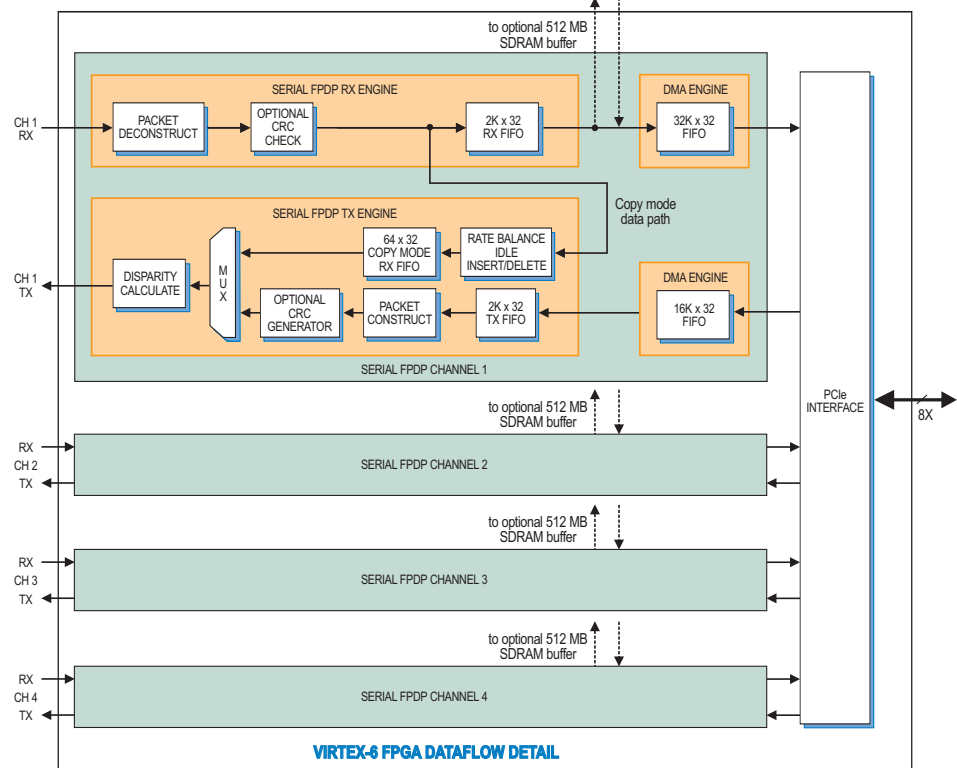

► Serial FPDP VITA 17.1 Compliance

The 71611 fully complies with the VITA 17.1 specification as follows:

What Link Rate does the interface support?

1.0625 Gbaud 2.125 Gbaud 2.5 Gbaud 3.125 Gbaud 4.25 Gbaud

What Serial FPDP function does the interface support?

Transmitter only Receiver only Transmitter & Receiver

Does the Receiver support Flow Control (setting the STOP signal)?

Always active Not supported Optional (selectable)

Does the Transmitter support Flow Control (stopping data transmission on receipt of a STOP signal)?

Always active Not supported Optional (selectable)

If the Transmitter supports Flow Control, after transmitting a STOP signal, how many 32-bit words can be received before a Receive FIFO overflow occurs?

Programmable

Does the interface support CRC?

Always active Not supported Optional (selectable)

Does the Transmitter support Copy Master Mode (insertion of additional IDLE ordered sets)?

Always active Not supported Optional (selectable)

Does the Receiver support Copy Mode (retransmission of data)?

Yes No

If Copy Mode is supported, what method is used for implementation (see VITA 17.1 Observation 6.1.4.4)?

Method 1 Method 2

Does the Receiver support Copy/Loop Mode (retransmission of data and setting Flow Control)?

Yes No

What type of media is supported?

Short Wave Laser Long Wave Laser Copper

What type of media connectors are supported?

LC SC ST Micro Twinax

Which fiber transmit data frames are supported in addition to Normal Data Fiber Frames (see VITA 17.1 Permission 7.3.3.1)?

Sync without Data Fiber Frames Sync with Data Fiber Frames

Does the Serial FPDP Transmitter stop in response to the Serial FPDP Receiver sending NRDY True (see VITA 17.1 Observation 7.3.2.2)?

Always Never Optional (selectable)

Are status bits kept up to date when there is no data to transmit by sending empty Serial FPDP Normal Data Fiber (see VITA 17.1 Rule 7.3.3.8, Recommendation 7.3.3.2 and Suggestion 7.3.3.1)?

Yes, empty frames transmitted No, status is not updated when no data is transmitted