



Features

- Complete software radio transceiver solution
- GateFlow IP Core 428, with four high-performance multiband DDCs and Interpolation Filter, factory-installed
- Improved dynamic range
- Two sets of 18-bit user-programmable FIR filter coefficients
- Decimation range from 2 to 65,536 in steps of 1
- Interpolation range from 2 to 32,768 in steps of 4

General Information

Model 7142-428, Digital Transceiver with Multiband DDC and Interpolation Filter core, is a complete software radio system in a PMC/XMC module. It includes four A/D and one D/A converters capable of bandwidths to 40 MHz and above for connection to HF or IF ports of a communications or radar system.

A/D and D/A Converter Stages

The front end accepts four full scale analog HF or IF inputs on front panel MMCX connectors at +10 dBm into 50 ohms with transformer coupling into Linear Technology LTC2255 14-bit 125 MHz A/D converters.

The digital outputs are delivered to the Virtex-4 FPGA for signal processing or for routing to other module resources.

A TI DAC5686 digital upconverter (DUC) and D/A accepts a baseband real or complex data stream from the FPGA with signal bandwidths up to 40 MHz.

When operating as an upconverter, it interpolates and translates real or complex baseband input signals to any IF center frequency between DC and 160 MHz. It delivers real or quadrature (I+Q) analog output samples at up to 320 MHz to the 16-bit D/A converter. Analog output is through a front panel MMCX connector at +4 dBm into 50 ohms.

If translation is disabled, the DAC5686 acts as an interpolating 16-bit D/A with output sampling rates up to 500 MHz.

Core 428 Multiband DDCs

The Core 428 downconverter translates any frequency band within the input bandwidth range down to zero frequency. The DDCs consist of two cascaded decimating

FIR filters. Each filter is capable of any decimation from 2 to 256. The decimations of the first stage filter and the second stage filter multiply to yield overall decimation factors up to 65,536. The second stage FIR may be bypassed for decimations of 256 or lower. The decimation of each DDC can be set independently. After each filter stage is a post filter gain stage. This gain is primarily used to compensate for bit growth in the filter at different decimations but may also be used to amplify small signals after out of band signals have been filtered out.

The NCO provides over 108 dB spurious-free dynamic range (SFDR). The FIR filter is capable of storing and utilizing two independent sets of 18-bit coefficients. These coefficients are user-programmable using RAM structures within the FPGA. NCO tuning frequency, decimation and filter coefficients can be changed dynamically.

Four identical Core 428 DDCs are factory installed in the 7142 FPGA. An input multiplexer allows any DDC to independently select any of the four A/D sources. The overall decimation range from 2 to 65,536, programmable in steps of 1, provides output bandwidths from 50 MHz down to 1.52 kHz for an A/D sampling rate of 125 MHz and assuming an 80% filter.

Core 428 Interpolation Filter

The Core 428 interpolation filter increases the sampling rate of real or complex baseband signals by a factor of 16 to 2048, programmable in steps of 4, and relieves the host processor from performing upsampling tasks. The interpolation filter can be used in series with the DUC's built-in interpolation, creating a maximum interpolation factor of 32,768. ➤

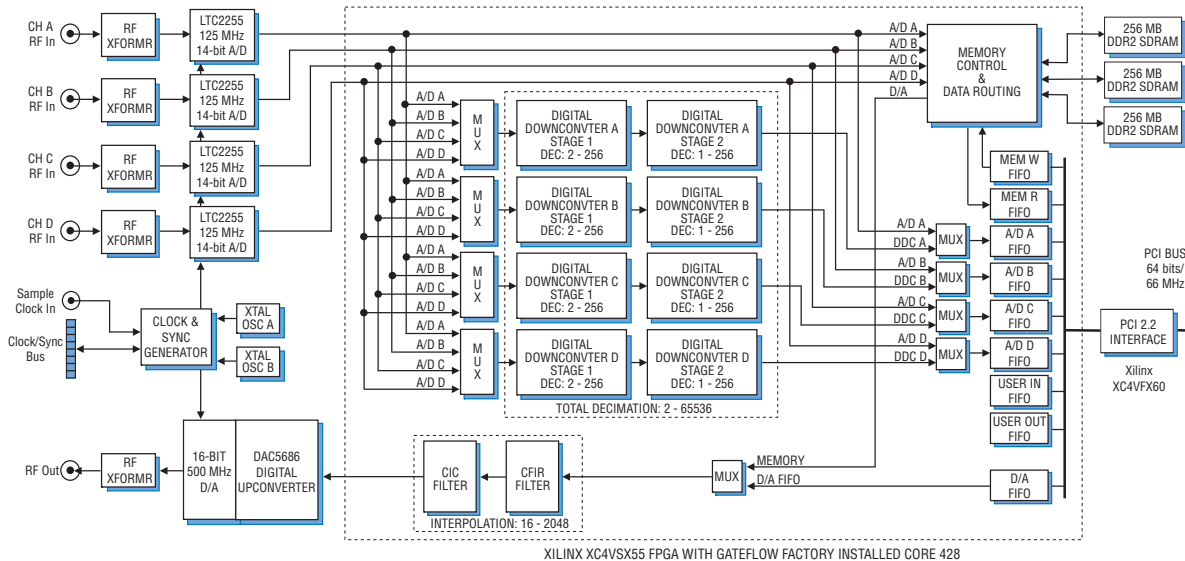

XILINX XC4VXS55 FPGA WITH GATEFLOW FACTORY INSTALLED CORE 428

XMC Interface

The Model 7142-428 complies with the VITA 42.0 XMC specification for carrier boards. This emerging standard provides, among others, for a 4X link with a 3.125 GHz bit clock between the XMC module and the carrier board. With two 4X links, the 7142-428 achieves 2.5 GB/sec streaming data transfer rate independent of the PCI interface and supports switched fabric protocols such as Serial RapidIO and PCI Express.

► Clocking and Synchronization

Two independent internal timing buses can provide either a single clock or two different clock rates for the input and output signal paths.

Each timing bus includes a clock, a sync, and a gate or trigger signal. Signals from either Timing Bus A or B can be selected as the timing source for the A/Ds and the upconverter and the D/A. Two internal crystal oscillators and a front panel reference input or LVDS bus can drive the timing buses.

A front panel 26-pin LVDS Clock/Sync connector allows multiple modules to be synchronized. In the slave mode, it accepts differential LVDS inputs that drive the clock, sync and gate signals for the two internal timing buses.

In the master mode, the LVDS bus can drive one or both sets of timing signals from the two internal timing buses for synchronizing multiple modules.

Up to seven slave 7142-428's can be driven from the LVDS bus master, supporting synchronous sampling and sync functions across all connected modules. Up to 80 modules may be synchronized with a Model 9190 Clock and Sync Generator.

Memory Resources

Three independent 256 MB banks of DDR2 SDRAM are available to the FPGA. Built-in memory functions include an A/D data transient capture mode with pre- and post-triggering and a D/A waveform generator mode. All memory banks can be easily accessed through the PCI interface using the on-board DMA controllers.

PCI Interface

The Model 7142-428 includes an industry-standard interface fully compliant with PCI 2.2 bus specifications. The interface includes nine separate DMA controllers for efficient transfers to and from the module.

Data widths of 32 or 64 bits and data rates of 33 or 66 MHz are supported.

Specifications

Front Panel Analog Signal Inputs

Input Type: Transformer-coupled, front panel female MMCX connectors

Transformer Type: Coil Craft WBC1-1TLB

Full Scale Input: +10 dBm into 50 ohms

3 dB Passband: 250 kHz to 300 MHz

A/D Converters

Type: Linear Technology LTC2255

Sampling Rate: 1 MHz to 125 MHz

Internal Clock: 125 MHz crystal osc.

External Clock: 1 to 125 MHz

Resolution: 14 bits

A/D Data Reduction Mode: Data from the A/Ds can be written directly into the FPGAs at a rate equal to the A/D clock decimated by any value between 1 and 4096

Front Panel Analog Signal Output

Output Type: Transformer-coupled, front panel female MMCX connector

Full Scale Output: +4 dBm into 50 ohms

3 dB Passband: 60 kHz to 300 MHz

Digital Upconverter

Type: TI DAC5686

Input Bandwidth: 40 MHz, max.

Output IF: DC to 160 MHz

Output Signal: Analog, real or quadrature

Sampling Rate: 320 MHz max; 500 MHz max. with upconversion disabled

Resolution: 16 bits

Clock Sources: Selectable from onboard A or B crystal oscillators, external or LVDS clocks

External Clock

Type: Front panel female MMCX connector, sine wave, 0 to +10 dBm, AC-coupled, 50 ohms

Sync/Gate Bus: 26-pin connector, dual clock/sync/gate input/output LVDS buses; one sync/gate input TTL signal

Field Programmable Gate Array

Type: One Xilinx Virtex-4 XC4VSX55 and one Xilinx Virtex-4 XC4VFX60

Memory

DDR2 SDRAM: 768 MB in three banks

PCI Interface

PCI Bus: 64-bit, 66 MHz (also supports 32-bit and/or 33 MHz)

Local Bus: 64-bit, 66 MHz

DMA: 9 channel demand-mode and chaining controller

Environmental

Operating Temp: 0° to 50° C

Storage Temp: -20° to 90° C

Relative Humidity: 0 to 95%, non-cond.

Size: Standard PMC module, 2.91 in. x 5.87 in.

Ordering Information

Model	Description
7142-428	Gateflow Transceiver with four DDCs and Interpolation Filter factory-installed - PMC/XMC

Contact Pentek for available options