

New!

# Models 57751 & 58751

# 2- or 4-Channel 500 MHz A/D, DDC, DUC, 2-or 4-Channel 800 MHz D/A with Virtex-7 FPGA - 6U OpenVPX



Model 58751



### Features

- Supports Xilinx Virtex-7 VXT FPGAs
- GateXpress supports dynamic FPGA reconfiguration across PCIe
- Two or four 500 MHz 12-bit A/Ds
- Two or four multiband DDCs (digital downconverters)
- One or two DUCs (digital upconverters)
- Two or four 800 MHz 16-bit D/As
- 4 or 8 GB of DDR3 SDRAM
- Sample clock synchronization to an external system reference
- PCI Express (Gen. 1, 2 & 3) interface up to x8
- LVPECL clock/sync bus for multiboard synchronization
- Optional LVDS connections to the Virtex-7 FPGA for custom I/O
- Optional 400 MHz 14-bit A/Ds
- Ruggedized and conduction-cooled versions available

### General Information

Models 57751 and 58751 are members of the Onyx® family of high-performance 6 U OpenVPX boards based on the Xilinx Virtex-7 FPGA. They consist of one or two Model 71751 XMC modules mounted on a VPX carrier board.

Model 57751 is a 6U board with one Model 71751 module while the Model 58751 is a 6U board with two XMC modules rather than one.

These models include two or four A/Ds, two or four multiband DDCs, one or two DUCs, two or four D/As and four or eight banks of memory.

### The Onyx Architecture

The Pentek Onyx Architecture features Virtex-7 FPGAs. All of the board's data and control paths are accessible by the FPGA, enabling factory-installed functions including data multiplexing, channel selection, data packing, gating, triggering and memory control. The Onyx Architecture organizes the FPGA as a container for data processing applications where each function exists as an intellectual property (IP) module.

Each member of the Onyx family is delivered with factory-installed applications ideally matched to the board's analog interfaces. The factory-installed functions in these models include two or four A/D acquisition and one or two D/A waveform playback IP modules. Each of the acquisition IP modules contains a powerful, programmable DDC IP core. The waveform playback IP module contains an interpolation IP core, ideal for matching playback rates to the data and decimation rates of the acquisition modules.

IP modules for DDR3 memories, controllers for all data clocking and synchronization functions, test signal generators, and a PCIe interface complete the factory-installed functions and enable these models to operate as a complete turnkey solutions, without the need to develop any FPGA IP.

### Extendable IP Design

For applications that require specialized function, users can install their own custom IP for data processing. Pentek GateFlow FPGA Design Kits include all of the factory-installed modules as documented source code. Developers can integrate their own IP with the Pentek factory-installed functions or use the GateFlow kit to completely replace the Pentek IP with their own.

### Xilinx Virtex-7 FPGA

The Virtex-7 FPGA site can be populated with one of two FPGAs to match the specific requirements of the processing task. Supported FPGAs are VX330T or VX690T. The VX690T features 3600 DSP48E1 slices and is ideal for modulation/demodulation, encoding/decoding, encryption/decryption, and channelization of the signals between transmission and reception. For applications not requiring large DSP resources or logic, the lower-cost VX330T can be installed.

Option -104 provides 24 LVDS pairs between the FPGA and the VPX P3 connector, Model 57751; P3 and P5, Model 58751.

Option -105 supports serial protocols by providing a 4X gigabit link between the FPGA and VPX P2, Model 57751; or one 4X link from each FPGA to P2 and an additional 4X link between the FPGAs, Model 58751. ➤

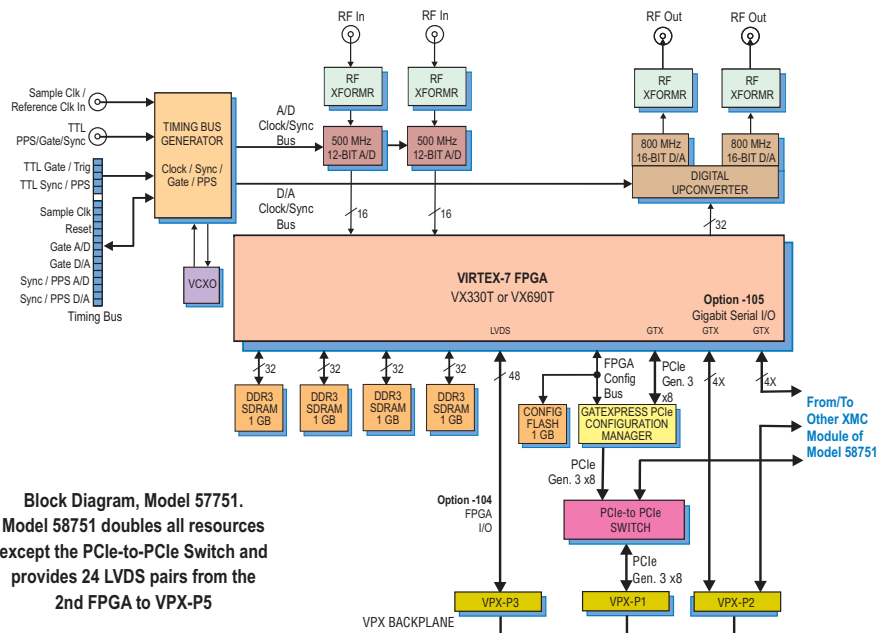

**Block Diagram, Model 57751.**  
 Model 58751 doubles all resources except the PCIe-to-PCIe Switch and provides 24 LVDS pairs from the 2nd FPGA to VPX-P5

**A/D Acquisition IP Modules**

These models feature two or four A/D Acquisition IP Modules for easily capturing and moving data. Each module can receive data from either of the two A/Ds, a test signal generator or from the D/A Waveform Playback IP Module in loopback mode.

Each IP Module has an associated memory bank for buffering data in FIFO mode or for storing data in transient capture mode. All memory banks are supported with DMA engines for easily moving A/D data through the PCIe interface.

These powerful linked-list DMA engines are capable of a unique Acquisition Gate Driven mode. In this mode, the length of a transfer performed by a link definition need not be known prior to data acquisition; rather, it is governed by the length of the acquisition gate. This is extremely useful in applications where an external gate drives acquisition and the exact length of that gate is not known or is likely to vary.

For each transfer, the DMA engine can automatically construct metadata packets containing A/D channel ID, a sample-accurate time stamp and data length information. These actions simplify the host processor's job of identifying and executing on the data.

**DDC IP Cores**

Within each A/D Acquisition IP Module is a powerful DDC IP core. Because of the flexible input routing of the A/D Acquisition IP Modules, many different configurations can be achieved including one A/D driving both DDCs or each of the two A/Ds driving its own DDC.

Each DDC has an independent 32-bit tuning frequency setting that ranges from DC to  $f_s$ , where  $f_s$  is the A/D sampling frequency. Each DDC can have its own unique decimation set-

ting, supporting as many as two different output bandwidths for the board. Decimations can be programmed from 2 to 131,072 providing a wide range to satisfy most applications.

The decimating filter for each DDC accepts a unique set of user-supplied 16-bit coefficients. The 80% default filters deliver an output bandwidth of  $0.8 \cdot f_s / N$ , where N is the decimation setting. The rejection of adjacent-band components within the 80% output bandwidth is better than 100 dB. Each DDC delivers a complex output stream consisting of 24-bit I + 24-bit Q or 16-bit I + 16-bit Q samples at a rate of  $f_s / N$ .

**D/A Waveform Playback IP Module**

The factory-installed functions in these models include one or two sophisticated D/A Waveform Playback IP modules. A linked-list controller allows users to easily play back to the dual D/As waveforms stored in either on-board memory or off-board host memory.

Parameters including length of waveform, delay from playback trigger, waveform repetition, etc. can be programmed for each waveform.

Up to 64 or 128 individual link entries can be chained together to create complex waveforms with a minimum of programming.

**GateXpress for FPGA Configuration**

The Onyx architecture includes GateXpress, a sophisticated FPGA-PCIe configuration manager for loading and reloading the FPGAs. At power-up, GateXpress immediately presents a target for the host computer to discover, effectively giving the FPGAs time to load from FLASH. This is especially important for larger FPGAs where the loading times can exceed the PCIe discovery window, typically 100 msec on most PCs.

The board's configuration FLASH can hold four FPGA images. Images can be factory-installed IP or custom IP created by the user. In this case, it's programmed into the FLASH via JTAG using Xilinx iMPACT or through the board's PCIe interface. At power-up the user can choose which image to load based on a hardware switch setting.

Once booted, GateXpress allows the user three options for dynamically reconfiguring the FPGAs with new IP images. The first option is to load an alternate image from FLASH through software control. The user selects the desired image and issues a reload command.

The second option is for applications where the FPGA image must be loaded directly through the PCIe interface. This is important in security situations where there can be no latent user image left in nonvolatile memory when power is removed. ➤

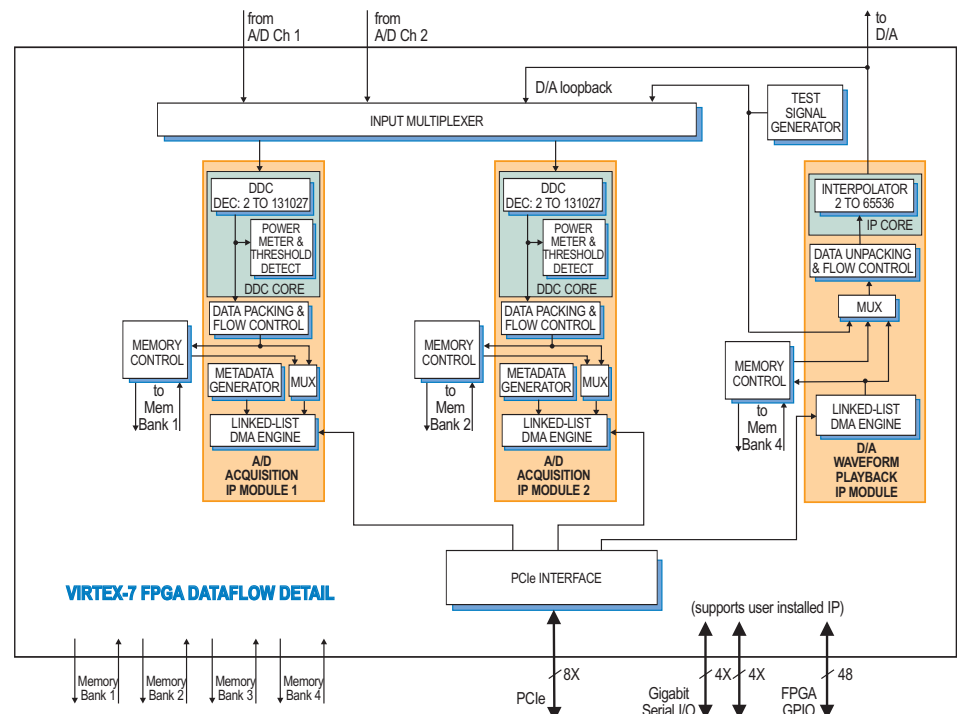

► In applications where the FPGA IP may need to change many times during the course of a mission, images can be stored on the host computer and loaded as needed.

The third option, typically used during development, allows the user to directly load the FPGAs through JTAG using Xilinx iMPACT.

In all three FPGA-loading scenarios, GateXpress handles the hardware negotiation thereby simplifying and streamlining the loading task. In addition, GateXpress preserves the PCIe configuration space allowing dynamic FPGA reconfiguration without the need to reset the host computer so it can rediscover the board. After the reload, the host computer simply continues to see the board with the expected device ID.

### A/D Converter Stages

The front end accepts two or four analog HF or IF inputs on front panel SSMC connectors with transformer-coupling into two or four Texas Instruments ADS5463 500 MHz, 12-bit A/D converters. Optionally, Texas Instruments ADS5474 400 MHz, 14-bit A/Ds may be installed.

The digital outputs are delivered into the Virtex-7 FPGA for signal processing, data capture and for routing to other board resources.

### Digital Upconverter and D/A Stages

One or two TI DAC5688 DUCs (digital upconverters) and D/As accept the baseband real or complex data stream from the FPGA and provide that input to the upconvert, interpolate and dual D/A stages.

When operating as a DUC, it interpolates and translates real or complex baseband input signals to any IF center frequency up to 360 MHz. It delivers real or quadrature (I+Q) analog outputs to the dual 16-bit D/A converter. Analog outputs are through front-panel SSMC connectors.

If translation is disabled, the DAC5688 acts as a dual interpolating 16-bit D/A with output sampling rates up to 800 MHz. In both modes the DAC5688 provides interpolation factors of 2x, 4x and 8x. In addition to the DAC5688, an FPGA-based interpolator core provides additional interpolation from 2x to 65,536x. The two interpolators can be combined to create a total range from 2x to 524,288x.

### Clocking and Synchronization

Two internal timing buses provide either a single clock or two different clock rates to the A/D and D/A signal paths.

Each timing bus includes a clock, sync and a gate or trigger signal. An on-board clock generator receives an external sample clock from the front panel SSMC connector. This clock can be used directly for either the A/D or D/A sections or can be divided by a built-in clock synthesizer circuit to provide different A/D and D/A clocks. In an alternate mode, the sample clock can be sourced from an on-board programmable VCXO (Voltage-Controlled Crystal Oscillator). In this mode, the front panel SSMC connector can be used to provide a 10 MHz reference clock for synchronizing the internal oscillator.

A front panel 26-pin LVPECL Clock/Sync connector allows multiple boards to be synchronized. In the slave mode, it accepts LVPECL inputs that drive the clock, sync and gate signals. In the master mode, the LVPECL bus can drive the timing signals for synchronizing multiple boards.

Multiple boards can be driven from the LVPECL bus master, supporting synchronous sampling and sync functions across all connected boards.

### Memory Resources

The architecture of these models supports four or eight independent DDR3 SDRAM memory banks. Each bank is 1 GB deep and is an integral part of the board's DMA capabilities, providing FIFO memory space for creating DMA packets. Built-in memory functions include multichannel A/D data capture, tagging and streaming.

In addition to the factory-installed functions, custom user-installed IP within the FPGA can take advantage of the memories for many other purposes.

### PCI Express Interface

These models include an industry-standard interface fully compliant with PCI Express Gen. 1, 2 and 3 bus specifications. Supporting PCIe links up to x8, the interface includes multiple DMA controllers for efficient transfers to and from the board. ►



► **Specifications**

**Model 57751:** 2 A/Ds, 2 DDCs, 1 DUC, 2 D/As

**Model 58751:** 4 A/Ds, 4 DDCs, 2 DUCs, 4 D/As

**Front Panel Analog Signal Inputs (2 or 4)**

**Input Type:** Transformer-coupled, front panel female SSMC connectors

**Transformer Type:** Coil Craft WBC4-6TLB

**Full Scale Input:** +5 dBm into 50 ohms

**3 dB Passband:** 300 kHz to 700 MHz

**A/D Converters (standard) (2 or 4)**

**Type:** Texas Instruments ADS5463

**Sampling Rate:** 20 MHz to 500 MHz

**Resolution:** 12 bits

**A/D Converters (option -014) (2 or 4)**

**Type:** Texas Instruments ADS5474

**Sampling Rate:** 20 MHz to 400 MHz

**Resolution:** 14 bits

**Digital Downconverters (2 or 4)**

**Decimation Range:** 2x to 131,072x in two programmable stages of 2x to 256x and one fixed 2x stage

**LO Tuning Freq. Resolution:** 32 bits, 0 to  $f_s$

**LO SFDR:** >120 dB

**Phase Offset Resolution:** 32 bits, 0 to 360 degrees

**FIR Filter:** 16-bit coefficients, 24-bit output, with user programmable coefficients  
**Default Filter Set:** 80% bandwidth, <0.3 dB passband ripple, >100 dB stopband attenuation

**D/A Converters (2 or 4)**

**Type:** Texas Instruments DAC5688

**Input Data Rate:** 250 MHz max.

**Output IF:** DC to 400 MHz max.

**Output Signal:** 2-channel real or 1-channel with frequency translation

**Output Sampling Rate:** 800 MHz max. with 2x, 4x or 8x interpolation

**Resolution:** 16 bits

**Digital Interpolators (1 or 2)**

**Interpolation Range:** 2x to 65,536x in two stages of 2x to 256x

**Total Interpolation Range (D/A and Digital combined):** 2x to 524,288x

**Front Panel Analog Signal Outputs (2 or 4)**

**Output:** Transformer-coupled, front panel female SSMC connectors

**Transformer:** Coil Craft WBC4-6TLB

**Full Scale Output:** +4 dBm into 50 ohms

**3 dB Passband:** 300 kHz to 700 MHz

**Sample Clock Sources (2 or 4)**

On-board clock synthesizer generates two clocks: one A/D clock and one D/A clock

**Clock Synthesizers (1 or 2)**

**Clock Source:** Selectable from on-board programmable VCXO (10 to 810 MHz), front panel external clock or LVPECL timing bus

**Synchronization:** VCXO can be locked to an external 4 to 180 MHz PLL system reference, typically 10 MHz

**Clock Dividers:** External clock or VCXO can be divided by 1, 2, 4, 8, or 16, independently for the A/D clock and D/A clock

**External Clocks (1 or 2)**

**Type:** Front panel female SSMC connector, sine wave, 0 to +10 dBm, AC-coupled, 50 ohms, accepts 10 to 800 MHz divider input clock or PLL system reference

**Timing Bus: (1 or 2)** 26-pin connector LVPECL bus includes, clock/sync/gate/PPS inputs and outputs; TTL signal for gate/trigger and sync/PPS inputs

**Field Programmable Gate Arrays (1 or 2)**

**Standard:** Xilinx Virtex-7 XC7VX330T-2

**Optional:** Xilinx Virtex-7 XC7VX690T-2

**Custom I/O**

**Option -104:** Provides 24 LVDS pairs between the FPGA and the VPX P3 connector, Model 57751; P3 and P5, Model 58751

**Option -105:** Supports serial protocols by providing a 4X gigabit link between the FPGA and VPX P2, Model 57751; or one 4X link from each FPGA to P2 and an additional 4X link between the FPGAs, Model 58751

**Memory Banks (4 or 8)**

**Type:** DDR3 SDRAM

**Size:** 1 GB each

**Speed:** 800 MHz (1600 MHz DDR)

**PCI-Express Interface**

**PCI Express Bus:** Gen. 1, 2 or 3: x4 or x8

**Environmental:** Level L1 & L2 air-cooled;

Level L3 ruggedized, conduction-cooled

**Size:** 3.937 in. x 6.717 in. (100 mm x 170.6 mm)

**Ordering Information**

Model	Description
57751	2-Channel 500 MHz A/D with DDC, DUC with 2-Channel 800 MHz D/A, and a Virtex-7 FPGA - 6U VPX
58751	4-Channel 500 MHz A/D with DDCs, DUCs with 4-Channel 800 MHz D/A, and two Virtex-7 FPGAs - 6U VPX

**Options:**

-014	400 MHz, 14-bit A/Ds
-076	XC7VX690T-2 FPGA
-104	LVDS I/O between the FPGA and P3 connector, Model 57751; P3 and P5 connectors, Model 58751
-105	Gigabit link between the FPGA and P2 connector, Model 57751; gigabit links from each FPGA to P2 connector, Model 78751

Contact Pentek for availability of rugged and conduction-cooled versions