

New!

Models 57650 & 58650

2- or 4-Channel 500 MHz A/D, DUC with 2-or 4-Channel 800 MHz D/A, Virtex-6 FPGA - 3U OpenVPX



Model 58650



Features

- Supports Xilinx Virtex-6 LXT and SXT FPGAs
- Two or four 500 MHz 12-bit A/Ds
- One or two DUCs (digital upconverters)
- Two or four 800 MHz 16-bit D/As
- Up to 2 or 4 GB of DDR3 SDRAM; or: 32 MB or 64MB of QDRII+ SRAM
- PCI Express (Gen. 1 & 2) interface up to x8
- Sample clock synchronization to an external system reference
- LVPECL clock/sync bus for multiboard synchronization
- Optional user-configurable gigabit serial interface
- Optional LVDS connections to the Virtex-6 FPGA for custom I/O
- Ruggedized and conduction-cooled versions available

General Information

Models 57650 and 58650 are members of the Cobalt® family of high-performance 6U OpenVPX boards based on the Xilinx Virtex-6 FPGA. They consist of one or two Model 71650 XMC modules mounted on a VPX carrier board.

Model 57650 is a 6U board with one Model 71650 module while the Model 58650 is a 6U board with two XMC modules rather than one.

These models include two or four A/Ds, one or two DUCs, two or four D/As and four or eight banks of memory.

The Cobalt Architecture

The Pentek Cobalt architecture features a Virtex-6 FPGA. All of the board's data and control paths are accessible by the FPGA, enabling factory-installed functions including data multiplexing, channel selection, data packing, gating, triggering and memory control. The Cobalt architecture organizes the FPGA as a container for data processing applications where each function exists as an intellectual property (IP) module.

Each member of the Cobalt family is delivered with factory-installed applications ideally matched to the board's analog interfaces. The factory-installed functions of these models include two or four A/D acquisition and one or two D/A waveform playback IP modules. IP modules for either DDR3 or QDRII+ memories, controllers for all data clocking and synchronization functions, test signal generators and a PCIe interface complete the factory-installed functions

and enable these models to operate as complete turnkey solutions, without the need to develop any FPGA IP.

Extendable IP Design

For applications that require specialized functions, users can install their own custom IP for data processing. Pentek GateFlow FPGA Design Kits include all of the factory installed modules as documented source code. Developers can integrate their own IP with the Pentek factory-installed functions or use the GateFlow Design Kit to completely replace the Pentek IP with their own.

Xilinx Virtex-6 FPGA

The Virtex-6 FPGA site can be populated with a variety of different FPGAs to match the specific requirements of the processing task. Supported FPGAs include: LX130T, LX240T, or SX315T. The SXT part features 1344 DSP48E slices and is ideal for modulation/demodulation, encoding/decoding, encryption/decryption, and channelization of the signals between transmission and reception. For applications not requiring large DSP resources, one of the lower-cost LXT FPGAs can be installed.

Option -104 provides 20 LVDS pairs between the FPGA and the VPX P3 connector, Model 57650; P3 and P5, Model 58650.

Option -105 supports serial protocols by providing a 4X gigabit link between the FPGA and VPX P2, Model 57650; or one 4X link from each FPGA to P2 and an additional 4X link between the FPGAs, Model 58650. ➤

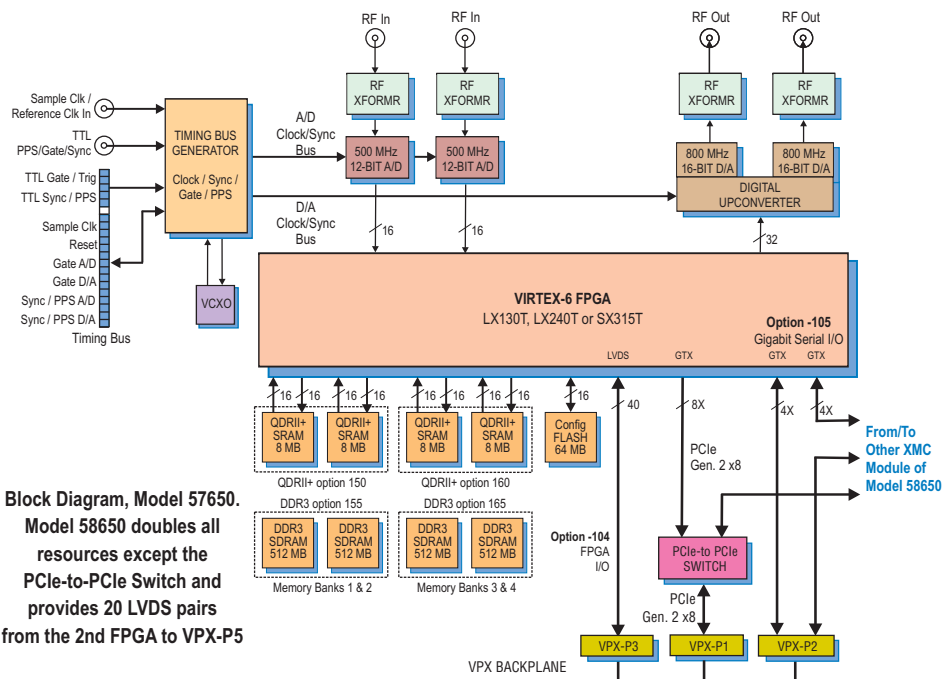

Block Diagram, Model 57650.

Model 58650 doubles all resources except the PCIe-to-PCIe Switch and provides 20 LVDS pairs from the 2nd FPGA to VPX-P5

A/D Acquisition IP Modules

These models feature two A/D Acquisition IP Modules for easy capture and data moving. Each IP module can receive data from either of the two A/Ds, a test signal generator or from the D/A Waveform Playback IP Module in loopback mode. Each IP module has an associated memory bank for buffering data in FIFO mode or for storing data in transient capture mode. All memory banks are supported with DMA engines for moving A/D data through the PCIe interface.

These powerful linked-list DMA engines are capable of a unique Acquisition Gate Driven mode. In this mode, the length of a transfer performed by a link definition need not be known prior to data acquisition; rather, it is governed by the length of the acquisition gate. This is extremely useful in applications where an external gate drives acquisition and the exact length of that gate is not known or is likely to vary.

For each transfer, the DMA engine can automatically construct metadata packets containing A/D channel ID, a sample-accurate time stamp, and data length information. These actions simplify the host processor's job of identifying and executing on the data.

D/A Waveform Playback IP Modules

These models include one or two factory-installed sophisticated D/A Waveform Playback IP modules. Linked-list controllers allow users to easily play back waveforms stored in either on-board memory or off-board host memory to the dual D/As.

Parameters including length of waveform, delay from playback trigger, waveform repetition, etc. can be programmed for each waveform.

Up to 64 or 128 individual link entries can be chained together to create complex waveforms with a minimum of programming.

A/D Converter Stages

The front end accepts two or four full scale analog HF or IF inputs on front panel SSMC connectors at +5 dBm into 50 ohms with transformer coupling into two or four Texas Instruments ADS5463 500 MHz, 12-bit A/D converters.

The digital outputs are delivered into the Virtex-6 FPGA for signal processing, data capture or for routing to other module resources.

Digital Upconverter and D/A Stages

One or two TI DAC5688 DUCs and D/As accept baseband real or complex data streams from the FPGAs and provide that input to the upconvert, interpolate and dual D/A stages.

When operating as a DUC, it interpolates and translates real or complex baseband input signals to any IF center frequency up to 360 MHz. It delivers real or quadrature (I+Q) analog outputs to the dual 16-bit D/A converter. Analog output is through front panel SSMC connectors.

If translation is disabled, the DAC5688 acts as a dual interpolating 16-bit D/A with output sampling rates up to 800 MHz. In both modes the DAC5688 provides interpolation factors of 2x, 4x and 8x.

Clocking and Synchronization

Two internal timing buses provide either a single clock or two different clock rates to the A/D and D/A signal paths.

Each timing bus includes a clock, sync and a gate or trigger signal. An on-board clock generator receives an external sample clock from the front panel SSMC connector. This clock can be used directly for either the A/D or D/A sections or can be divided by a built-in clock synthesizer circuit to provide different A/D and D/A clocks. In an alternate mode, the sample clock can be sourced from an onboard programmable voltage-controlled crystal oscillator. In this mode, the front panel SSMC connector can be used to provide a 10 MHz reference clock for synchronizing the internal oscillator.

A front panel 26-pin LVPECL Clock/Sync connector allows multiple boards to be synchronized. In the slave mode, it accepts LVPECL inputs that drive the clock, sync and gate signals. In the master mode, the LVPECL bus can drive the timing signals for synchronizing multiple boards.

Multiple boards can be driven from the LVPECL bus master, supporting synchronous sampling and sync functions across all connected boards.

Memory Resources

The Cobalt architecture supports up to four or eight independent memory banks which can be configured with all QDRII+ SRAM, DDR3 SDRAM, or as combination of two banks of each type of memory.

Each QDRII+ SRAM bank can be up to 8 MB deep and is an integral part of the

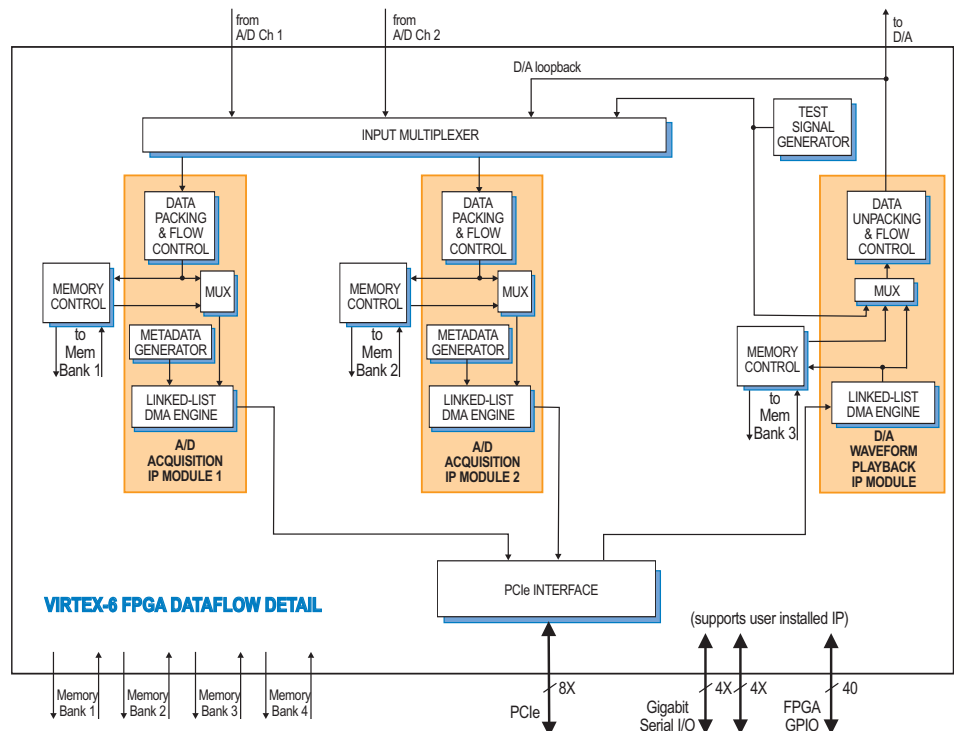

► board's DMA capabilities, providing FIFO memory space for creating DMA packets. For applications requiring deep memory resources, DDR3 SDRAM banks can each be up to 512 MB deep. Built-in memory functions include A/D data transient capture mode and D/A waveform playback mode.

In addition to the factory-installed functions, custom user-installed IP within the FPGA can take advantage of the memories for many other purposes.

PCI Express Interface

These models include an industry-standard interface fully compliant with PCI Express Gen. 1 and 2 bus specifications. Supporting PCIe links up to x8, the interface includes multiple DMA controllers for efficient transfers to and from the board.

Specifications

Model 57650: 2 A/Ds, 1 DUC, 2 D/As

Model 58650: 4 A/Ds, 2 DUCs, 4 D/As

Front Panel Analog Signal Inputs (2 or 4)

Input Type: Transformer-coupled, front panel female SSMC connectors

Transformer Type: Coil Craft WBC4-6TLB

Full Scale Input: +5 dBm into 50 ohms
3 dB Passband: 300 kHz to 700 MHz

A/D Converters (standard) (2 or 4)

Type: Texas Instruments ADS5463

Sampling Rate: 20 MHz to 500 MHz

Resolution: 12 bits

A/D Converters (option - 014) (2 or 4)

Type: Texas Instruments ADS5474

Sampling Rate: 20 MHz to 400 MHz

Resolution: 14 bits

D/A Converters (2 or 4)

Type: Texas Instruments DAC5688

Input Data Rate: 250 MHz, max.

Output IF: DC to 400 MHz, max.

Output Signal: 2-channel real or 1-channel with frequency translation

Output Sampling Rate: 800 MHz, max. with interpolation

Resolution: 16 bits

Front Panel Analog Signal Outputs (2 or 4)

Output Type: Transformer-coupled, front panel female SSMC connectors

Transformer Type: Coil Craft WBC4-6TLB

Full Scale Output: +4 dBm into 50 ohms
3 dB Passband: 300 kHz to 700 MHz

Sample Clock Sources (2 or 4)

On-board clock synthesizer generates two clocks: one A/D clock and one D/A clock

Clock Synthesizers (1 or 2)

Clock Source: Selectable from on-board programmable VCXO (10 to 810 MHz), front panel external clock or LVPECL timing bus

Synchronization: VCXO can be locked to an external 4 to 180 MHz PLL system reference, typically 10 MHz

Clock Dividers: External clock or VCXO can be divided by 1, 2, 4, 8, or 16, independently for the A/D clock and D/A clock

External Clocks (1 or 2)

Type: Front panel female SSMC connector, sine wave, 0 to +10 dBm, AC-coupled, 50 ohms, accepts 10 to 800 MHz divider input clock or PLL system reference

Timing Bus (1 or 2): 26-pin front panel connector LVPECL bus includes, clock/sync/gate/PPS inputs and outputs; TTL signal for gate/trigger and sync/PPS inputs

External Trigger Inputs (1 or 2)

Type: Front panel female SSMC connector, LVTTTL

Function: Programmable functions include: trigger, gate, sync and PPS

Field Programmable Gate Arrays (1 or 2)

Standard: Xilinx Virtex-6 XC6VLX130T-2
Optional: Xilinx Virtex-6 XC6VLX240T-2 or XC6VSX315T-2

Custom I/O

Option -104: Provides 20 LVDS pairs between the FPGA and the VPX P3 connector, Model 57650; P3 and P5, Model 58650

Option -105: Supports serial protocols by providing a 4X gigabit link between the FPGA and VPX P2, Model 57650; or one 4X link from each FPGA to P2 and an additional 4X link between the FPGAs, Model 58650

Memory Banks (1 or 2)

Option 150 or 160: Two 8 MB QDRII+ SRAM memory banks, 400 MHz DDR

Option 155 or 165: Two 512 MB DDR3 SDRAM memory banks, 400 MHz DDR

PCI-Express Interface

PCI Express Bus: Gen. 1 or 2: x4 or x8

Environmental: Level L1 & L2 air-cooled; Level L3 ruggedized, conduction-cooled

Size: 3.937 in. x 6.717 in. (100 mm x 170.6 mm)

Ordering Information

Model	Description
57650	Two 500 MHz A/Ds, One DUC, Two 800 MHz D/As with Virtex-6 FPGA - 6U VPX
58650	Four 500 MHz A/Ds, Two DUCs, Four 800 MHz D/As with two Virtex-6 FPGAs - 6U VPX

Options:

-002*	-2 FPGA speed grade
-014	400 MHz, 14-bit A/Ds
-062	XC6VLX240T FPGA
-064	XC6VSX315T FPGA
-104	LVDS I/O between the FPGA and P3 connector, Model 57650; P3 and P5 connectors, Model 58650
-105	Gigabit link between the FPGA and P2 connector, Model 57650; gigabit links from each FPGA to P2 connector, Model 78650
-150	Two 8 MB QDRII+ SRAM Memory Banks (Banks 1 and 2)
-160	Two 8 MB QDRII+ SRAM Memory Banks (Banks 3 and 4)
-155	Two 512 MB DDR3 SDRAM Memory Banks (Banks 1 and 2)
-165	Two 512 MB DDR3 SDRAM Memory Banks (Banks 3 and 4)

* This option is always required

Contact Pentek for availability of rugged and conduction-cooled versions