

New!

Models 57640 & 58640

1- or 2-Channel 3.6 GHz and 2- or 4-Channel 1.8 GHz, 12-bit A/D, Virtex-6 FPGA - 6U OpenVPX



Model 58640



General Information

Models 57640 and 58640 are members of the Cobalt® family of high-performance 6U OpenVPX boards based on the Xilinx Virtex-6 FPGA. They consist of one or two Model 71640 XMC modules mounted on a VPX carrier board.

Model 57640 is a 6U board with one Model 71640 module while the Model 58640 is a 6U board with two XMC modules rather than one.

These models include one or two 3.6 GHz, 12-bit A/D converters and four or eight banks of memory.

The Cobalt Architecture

The Pentek Cobalt architecture features a Virtex-6 FPGA. All of the board's data and control paths are accessible by the FPGA, enabling factory-installed functions including data multiplexing, channel selection, data packing, gating, triggering and memory control. The Cobalt architecture organizes the FPGA as a container for data processing applications where each function exists as an intellectual property (IP) module.

Each member of the Cobalt family is delivered with factory-installed applications ideally matched to the board's analog interfaces. The factory-installed functions of these models include one or two A/D acquisition IP modules. In addition, IP modules for DDR3 memories, controllers for all data clocking and synchronization functions, a test signal generator and a PCIe interface complete the factory-installed functions and enable

these models to operate as complete turn-key solutions, without the need to develop any FPGA IP.

Extendable IP Design

For applications that require specialized functions, users can install their own custom IP for data processing. Pentek GateFlow® FPGA Design Kits include all of the factory installed modules as documented source code. Developers can integrate their own IP with the Pentek factory-installed functions or use the GateFlow Design Kit to completely replace the Pentek IP with their own.

Xilinx Virtex-6 FPGA

The Virtex-6 FPGA site can be populated with a variety of different FPGAs to match the specific requirements of the processing task. Supported FPGAs include: LX130T, LX240T, or SX315T. The SXT part features 1344 DSP48E slices and is ideal for modulation/demodulation, encoding/decoding, encryption/decryption, and channelization of the signals between transmission and reception. For applications not requiring large DSP resources, one of the lower-cost LXT FPGAs can be installed.

Option -104 provides 20 LVDS pairs between the FPGA and the VPX P3 connector, Model 57640; P3 and P5, Model 58640.

Option -105 supports serial protocols by providing a 4X gigabit link between the FPGA and VPX P2, Model 57640; or one 4X link from each FPGA to P2 and an additional 4X link between the FPGAs, Model 58640. ▶

Features

- Ideal radar and software radio interface solution
- Supports Xilinx Virtex-6 LXT and SXT FPGAs
- One or two 1-channel mode with 3.6 GHz, 12-bit A/Ds
- Two or four 2-channel mode with 1.8 GHz, 12-bit A/Ds
- 2 or 4 GB of DDR3 SDRAM
- PCI Express (Gen. 1 & 2) interface up to x8
- μSync clock/sync bus for multiboard synchronization
- Optional user-configurable gigabit serial interface
- Optional LVDS connections to the Virtex-7 FPGA for custom I/O
- Ruggedized and conduction-cooled versions available

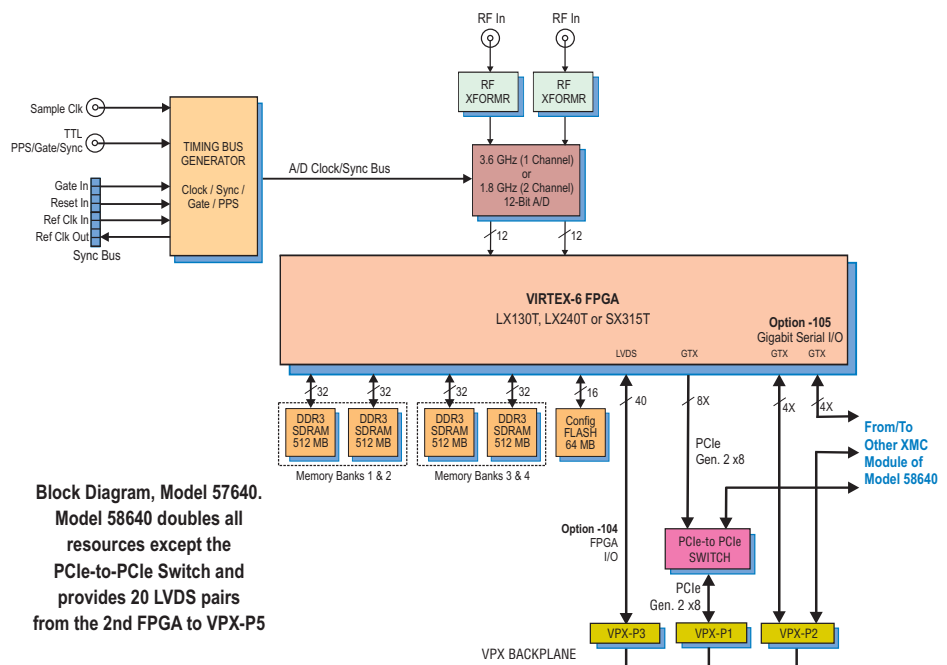

A/D Acquisition IP Modules

These models feature one or two A/D Acquisition IP Modules for easy capture and data moving. The IP modules can receive data from the A/Ds, or a test signal generator. The IP modules have associated memory banks for buffering data in FIFO mode or for storing data in transient capture mode. In single-channel mode, all banks are used to store the single-channel of input data. In dual-channel mode, memory banks 1 and 2 store data from input channel 1 and memory banks 3 and 4 store data from input channel 2. In both modes, continuous, full-rate transient capture of 12-bit data is supported.

The memory banks are supported with a DMA engine for moving A/D data through the PCIe interface. This powerful linked-list DMA engine is capable of a unique Acquisition Gate Driven mode. In this mode, the length of a transfer performed by a link definition need not be known prior to data acquisition; rather, it is governed by the length of the acquisition gate. This is extremely useful in applications where an external gate drives acquisition and the exact length of that gate is not known or is likely to vary.

For each transfer, the DMA engine can automatically construct metadata packets containing a sample-accurate time stamp, and data length information. These actions simplify the host processor's job of identifying and executing on the data.

A/D Converter Stage

The front end accepts analog HF or IF inputs on a pair of front panel SSMC connectors with transformer coupling into a Texas Instruments ADC12D1800 12-bit A/D. The converter operates in single-channel interleaved mode with a sampling rate of 3.6 GHz and an input bandwidth of 1.75 GHz; or, in dual-channel mode with a sampling rate of 1.8 GHz and input bandwidth of 2.8 GHz.

The ADC12D1800 provides a programmable 15-bit gain adjustment allowing these models to have a full scale input range of +2 dBm to +4 dBm. A built-in AutoSync feature supports A/D synchronization across multiple boards.

The A/D digital outputs are delivered into the Virtex-6 FPGA for signal processing, data capture or for routing to other module resources.

Clocking and Synchronization

These models accept a 1.8 GHz dual-edge sample clock via front panel SSMC connectors. A second front panel SSMC accepts a TTL signal that can function as Gate, PPS or Sync.

A front panel multi-pin sync bus connector allows multiple boards to be

synchronized, ideal for larger multichannel systems. The sync bus includes gate, reset and in and out reference clock signals. Multiple boards can be synchronized using the Cobalt high speed sync board to drive the sync bus.

Memory Resources

The Cobalt architecture supports four or eight independent memory banks of DDR3 SDRAM. Each bank is 512 MB deep and is an integral part of the board's DMA and data capture capabilities. Built-in memory functions include an A/D data transient capture mode for taking snapshots of data for transfer to a host computer.

In addition to the factory-installed functions, custom user-installed IP within the FPGA can take advantage of the memories for many other purposes.

PCI Express Interface

These models include an industry-standard interface fully compliant with PCI Express Gen. 1 and 2 bus specifications. Supporting PCIe links up to x8, the interface includes multiple DMA controllers for efficient transfers to and from the board. ➤

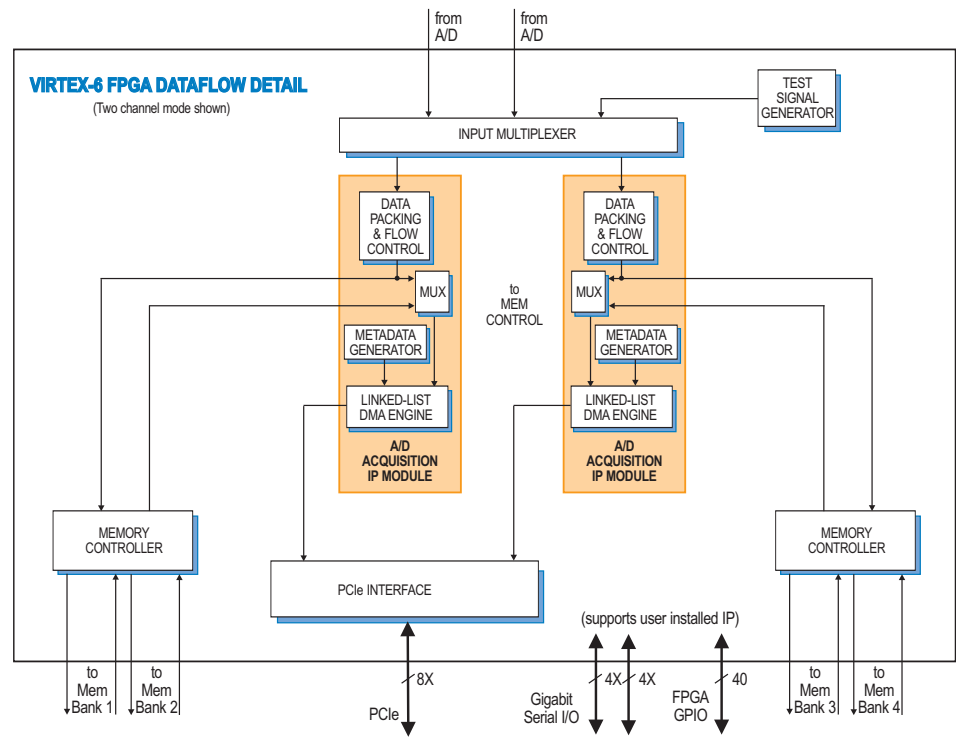

► **Specifications**

Model 57640: One A/D

Model 58640: Two A/Ds

Front Panel Analog Signal Inputs (2 or 4)

Input Type: Transformer-coupled, front panel female SSMC connectors

A/D Converter (1 or 2)

Type: Texas Instruments ADC12D1800

Sampling Rate: Single-channel mode: 500 MHz to 3.6 GHz; dual-channel mode: 150 MHz to 1.8 GHz

Resolution: 12 bits

Input Bandwidth: single-channel mode: 1.75 GHz; dual-channel mode: 2.8 GHz

Full Scale Input: +2 dBm to +4 dBm, programmable

Sample Clock Sources (1 or 2)

Front panel SSMC connector

Sync Bus (1 or 2)

Multi-pin connectors, bus includes gate, reset and in and out ref clock

External Trigger Input (1 or 2)

Type: Front panel female SSMC connector, TTL

Function: Programmable functions include: trigger, gate, sync and PPS

Field Programmable Gate Array (1 or 2)

Standard: Xilinx Virtex-6 XC6VLX130T-2

Optional: Xilinx Virtex-6 XC6VLX240T-2 or XC6VSX315T-2

Custom I/O

Option -104: Provides 20 LVDS pairs between the FPGA and the VPX P3 connector, Model 57640; P3 and P5, Model 58640

Option -105: Supports serial protocols by providing a 4X gigabit link between the FPGA and VPX P2, Model 57640; or one 4X link from each FPGA to P2 and an additional 4X link between the FPGAs, Model 58640

Memory Banks (1 or 2)

Four 512 MB DDR3 SDRAM memory banks, 400 MHz DDR

PCI-Express Interface

PCI Express Bus: Gen. 1 or 2: x4 or x8

Environmental: Level L1 & L2 air-cooled;

Level L3 ruggedized, conduction-cooled

Size: 3.937 in. x 6.717 in. (100 mm x 170.6 mm)

Ordering Information

Model	Description
57640	1-Ch. 3.6 GHz or 2-Ch. 1.8 GHz, 12-bit A/D, Virtex-6 FPGA - 6U VPX
58640	2-Ch. 3.6 GHz or 4-Ch. 1.8 GHz, 12-bit A/D with two Virtex-6 FPGAs - 6U VPX

Options:

-002*	-2 FPGA speed grade
-062	XC6VLX240T
-064	XC6VSX315T
-104	LVDS I/O between the FPGA and P3 connector, Model 57640; P3 and P5 connectors, Model 58640
-105	Gigabit link between the FPGA and P2 connector, Model 57640; gigabit links from each FPGA to P2 connector, Model 78640
-155*	Two 512 MB DDR3 SDRAM Memory Banks (Banks 1 and 2)
-165*	Two 512 MB DDR3 SDRAM Memory Banks (Banks 3 and 4)

* These options are always required

Contact Pentek for availability of rugged and conduction-cooled versions