

New!

Model 53741

1-Ch. 3.6 GHz or 2-Ch. 1.8 GHz, 12-bit A/D, w/ Wideband DDC, Virtex-7 FPGA - 3U VPX



Model 53741 COTS (left) and rugged version



Features

- Ideal radar and software radio interface solution
- Supports Xilinx Virtex-7 VXT FPGAs
- GateXpress supports dynamic FPGA reconfiguration across PCIe
- One-channel mode with 3.6 GHz, 12-bit A/D
- Two-channel mode with 1.8 GHz, 12-bit A/Ds
- Programmable one- or two-channel DDC (Digital Downconverter)
- 4 GB of DDR3 SDRAM
- μ Sync clock/sync bus for multiboard synchronization
- PCI Express (Gen. 1, 2 & 3) interface up to x8
- Optional user-configurable gigabit serial interface
- Optional LVDS connections to the Virtex-7 FPGA for custom I/O
- Compatible with several VITA standards including: VITA-46, VITA-48 and VITA-65 (OpenVPX™ System Specification)

General Information

Model 53741 is a member of the Onyx® family of high-performance 3U VPX boards based on the Xilinx Virtex-7 FPGA. A high-speed data converter with a programmable digital downconverter, it is suitable for connection to HF or IF ports of a communications or radar system. Its built-in data capture features offer an ideal turnkey solution.

It includes a 3.6 GHz, 12-bit A/D converter and four banks of memory. In addition to supporting PCI Express Gen. 3 as a native interface, Model 53741 includes an optional connection to the Virtex-7 FPGA for custom I/O.

The Onyx Architecture

Based on the proven design of the Pentek Cobalt family, Onyx raises the processing performance with the new flagship family of Virtex-7 FPGAs from Xilinx. As the central feature of the board architecture, the FPGA has access to all data and control paths, enabling factory-installed functions including data multiplexing, channel selection, data packing, gating, triggering and memory control. The Onyx Architecture organizes the FPGA as a container for data processing applications where each function exists as an intellectual property (IP) module.

Each member of the Onyx family is delivered with factory-installed applications ideally matched to the board's analog interfaces. The 53741 factory-installed functions include an A/D acquisition IP module and a programmable digital downconverter. In addition, IP modules for DDR3 SDRAM

memories, a controller for all data clocking and synchronization functions, a test signal generator and a PCIe interface complete the factory-installed functions and enable the 53741 to operate as a complete turnkey solution, without the need to develop any FPGA IP.

Extendable IP Design

For applications that require specialized functions, users can install their own custom IP for data processing. Pentek GateFlow FPGA Design Kits include all of the factory installed modules as documented source code. Developers can integrate their own IP with the Pentek factory-installed functions or use the GateFlow Design Kit to completely replace the Pentek IP with their own.

Xilinx Virtex-7 FPGA

The Virtex-7 FPGA site can be populated with one of two FPGAs to match the specific requirements of the processing task. Supported FPGAs are VX330T or VX690T. The VX690T features 3600 DSP48E1 slices and is ideal for modulation/demodulation, encoding/decoding, encryption/decryption, and channelization of the signals between transmission and reception. For applications not requiring large DSP resources or logic, the lower-cost VX330T can be installed.

Option -104 provides 20 pairs of LVDS connections between the FPGA and the VPX P2 connector for custom I/O.

Option -105 provides one 8X or two 4X gigabit links between the FPGA and the VPX P1 connector to support serial protocols. ➤

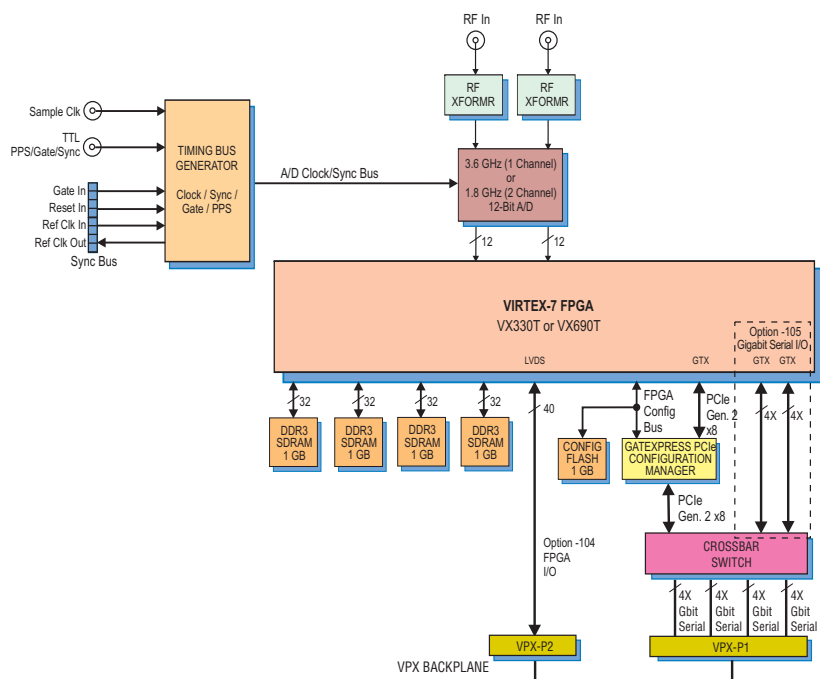

A/D Acquisition IP Module

The 53741 features an A/D Acquisition IP Module for easy capture and data moving. The IP module can receive data from the A/D, or a test signal generator. The IP module has associated memory banks for buffering data in FIFO mode or for storing data in transient capture mode. In single-channel mode, all four banks are used to store the single-channel of input data. In dual-channel mode, memory banks 1 and 2 store data from input channel 1 and memory banks 3 and 4 store data from input channel 2. In both modes, continuous, full-rate transient capture of 12-bit data is supported.

The memory banks are supported with a DMA engine for moving A/D data through the PCIe interface. This powerful linked-list DMA engine is capable of a unique Acquisition Gate Driven mode. In this mode, the length of a transfer performed by a link definition need not be known prior to data acquisition; rather, it is governed by the length of the acquisition gate. This is extremely useful in applications where an external gate drives acquisition and the exact length of that gate is not known or is likely to vary.

For each transfer, the DMA engine can automatically construct metadata packets containing a sample-accurate time stamp and data length information. These actions simplify the host processor's job of identifying and executing on the data.

DDC IP Cores

Within the FPGA is a powerful DDC IP core. The core supports a single-channel mode, accepting data samples from the A/D at the full 3.6 GHz rate. Additionally, a dual-channel mode supports the A/D's 1.8 GHz two-channel operation.

In dual-channel mode, each DDC has an independent 32-bit tuning frequency setting that ranges from DC to f_s , where f_s is the A/D sampling frequency.

In single-channel mode, decimation can be programmed to 8x, 16x or 32x. In dual-channel mode, both channels share the same decimation rate, programmable to 4x, 8x or 16x.

The decimating filter for each DDC accepts a unique set of user-supplied 16-bit coefficients. The 80% default filters deliver an output bandwidth of $0.8 * f_s / N$, where N is the decimation setting. The rejection of adjacent-band components within the 80% output bandwidth is better than 100 dB. Each DDC delivers a complex output stream consisting of 16-bit I + 16-bit Q samples at a rate of f_s / N .

► GateXpress for FPGA Configuration

The Onyx architecture includes GateXpress, a sophisticated FPGA-PCIe configuration manager for loading and reloading the FPGA. At power up, GateXpress immediately presents a PCIe target for the host computer to discover, effectively giving the FPGA time to load from FLASH. This is especially important for larger FPGAs where the loading times can exceed the PCIe discovery window, typically 100 msec on most PCs.

The board's configuration FLASH can hold four FPGA images. Images can be factory-installed IP or custom IP created by the user, and programmed into the FLASH via JTAG using Xilinx iMPACT or through the board's PCIe interface. At power up the user can choose which image will load based on a hardware switch setting.

Once booted, GateXpress allows the user three options for dynamically reconfiguring the FPGA with a new IP image. The first is the option to load an alternate image from FLASH through software control. The user selects the desired image and issues a reload command.

The second option is for applications where the FPGA image must be loaded directly through the PCIe interface. This is important in security situations where there can be no latent user image left in nonvolatile memory when power is removed. In applications where the FPGA IP may need to change many times during the course of a mission, images can be stored on the host computer and loaded through PCIe as needed.

The third option, typically used during development, allows the user to directly load the FPGA through JTAG using Xilinx iMPACT.

In all three FPGA loading scenarios, GateXpress handles the hardware negotiation simplifying and streamlining the loading task. In addition, GateXpress preserves the PCIe configuration space allowing dynamic FPGA reconfiguration without needing to reset the host computer to rediscover the board. After the reload, the host simply continues to see the board with the expected device ID. ►

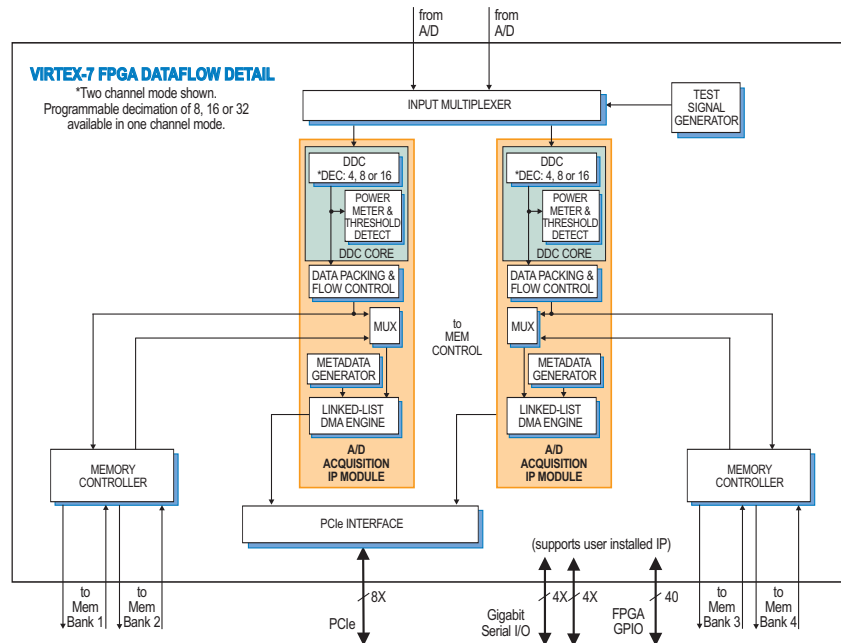

Memory Resources

The 53741 architecture supports four independent DDR3 SDRAM memory banks. Each bank is 1 GB deep and is an integral part of the board's DMA capabilities, providing FIFO memory space for creating DMA packets.

Crossbar Switch

The 53741 features a unique high-speed switching configuration. A fabric-transparent crossbar switch bridges numerous interfaces and components on the board using gigabit serial data paths with no latency. Programmable signal input equalization and output pre-emphasis settings enable optimization.

Model 8267

The Model 8267 is a fully-integrated development system for Pentek Cobalt, Onyx and Flexor 3U VPX boards. It was created to save engineers and system integrators the time and expense associated with building and testing a development system that ensures optimum performance of Pentek boards.



Ordering Information

Model	Description
53741	1-Ch. 3.6 GHz or 2-Ch. 1.8 GHz, 12-bit A/D with Wideband DDC, Virtex-7 FPGA - 3U VPX
Options:	
-073	XC7VX330T-2 FPGA
-076	XC7VX690T-2 FPGA
-104	LVDS FPGA I/O to VPX P2
-105	Gigabit serial FPGA I/O to VPX P1

Contact Pentek for availability of rugged and conduction-cooled versions

Model	Description
8267	VPX Development System See 8267 Datasheet for Options

A/D Converter Stage

The front end accepts analog HF or IF inputs on a pair of front panel SSMC connectors with transformer coupling into a Texas Instruments ADC12D1800 12-bit A/D. The converter operates in single-channel interleaved mode with a sampling rate of 3.6 GHz and an input bandwidth of 1.75 GHz; or, in dual-channel mode with a sampling rate of 1.8 GHz and input bandwidth of 2.8 GHz.

The ADC12D1800 provides a programmable 15-bit gain adjustment allowing the 53741 to have a full scale input range of +2 dBm to +4 dBm. A built-in AutoSync feature supports A/D synchronization across multiple boards.

Clocking and Synchronization

The 53741 accepts a 1.8 GHz dual-edge sample clock via a front panel SSMC connector. A second front panel SSMC accepts a TTL signal that can function as Gate, PPS or Sync.

A front panel μ Sync bus connector allows multiple boards to be synchronized, ideal for multichannel systems. The μ Sync bus includes gate, reset, and in and out reference clock signals. Two 53741's can be synchronized with a simple cable. For larger systems, multiple 53741's can be synchronized using the Model 5392 high-speed sync board to drive the sync bus.

PCI Express Interface

The Model 53741 includes an industry-standard interface fully compliant with PCI Express Gen. 1, 2 and 3 bus specifications. Supporting PCIe links up to x8, the interface includes multiple DMA controllers.

Specifications

Front Panel Analog Signal Inputs

Input Type: Transformer-coupled, front panel female SSMC connectors

A/D Converter

Type: Texas Instruments ADC12D1800

Sampling Rate: Single-channel mode: 500 MHz to 3.6 GHz; dual-channel mode: 150 MHz to 1.8 GHz

Resolution: 12 bits

Input Bandwidth: single-channel mode: 1.75 GHz; dual-channel mode: 2.8 GHz
Full Scale Input: +2 dBm to +4 dBm, programmable

Digital Downconverters

Modes: One or two channels, programmable

Supported Sample Rate: One-channel mode: 3.6 GHz, two-channel mode: 1.8 GHz

Decimation Range: One-channel mode: 8x, 16x or 32x, two-channel: 4x, 8x, or 16x

LO Tuning Freq. Resolution: 32 bits, 0 to f_s

LO SFDR: >120 dB

Phase Offset Resolution: 32 bits, 0 to 360 degrees

FIR Filter: User-programmable 18-bit coefficients

Default Filter Set: 80% bandwidth, <0.3 dB passband ripple, >100 dB stopband attenuation

Sample Clock Source: Front panel SSMC connector

Timing Bus: 19-pin μ Sync bus connector includes sync and gate/trigger inputs, CML

External Trigger Input

Type: Front panel female SSMC connector, LVTTTL

Function: Programmable functions include: trigger, gate, sync and PPS

Field Programmable Gate Array

Standard: Xilinx Virtex-7 XC7VX330T-2

Optional: Xilinx Virtex-7 XC7VX690T-2

Custom I/O

Option -104: Provides 20 pairs of LVDS connections between the FPGA and the VPX P2 connector for custom I/O

Option -105: Provides one 8X or two 4X gigabit links between the FPGA and the VPX P1 to support serial protocols

Memory

Type: DDR3 SDRAM

Size: Four banks, 1 GB each

Speed: 800 MHz (1600 MHz DDR)

PCI-Express Interface

PCI Express Bus: Gen. 1, 2 or 3: x4 or x8

Environmental

Operating Temp: 0° to 50° C

Storage Temp: -20° to 90° C

Relative Humidity: 0 to 95%, non-cond.

Size: 3.937 in. x 6.717 in. (100 mm x 170.6 mm)

VPX Families

Pentek offers two families of 3U VPX products: the 53xxx and the 52xxx. For more information on a 52xxx product, please refer to the product datasheet. The table below provides a comparison of their main features.

	VPX Family Comparison	
	52xxx	53xxx
Form Factor	3U VPX	
# of XMCs	One XMC	
Crossbar Switch	No	Yes
PCIe path	VPX P1	VPX P1 or P2
PCIe width	x4	x4 or x8
Option -104 path	24 pairs on VPX P2	20 pairs on VPX P2
Option -105 path	Two x4 or one x8 on VPX P1	Two x4 or one x8 on VPX P1 or P2
Lowest Power	Yes	No
Lowest Price	Yes	No