



Model 53641 COTS (left) and rugged version



General Information

Model 53641 is a member of the Cobalt® family of high performance 3U VPX boards based on the Xilinx Virtex-6 FPGA. A high-speed data converter with a programmable digital downconverter, it is suitable for connection to HF or IF ports of a communications or radar system. Its built-in data capture features offer an ideal turnkey solution.

The 53641 includes a 3.6 GHz, 12-bit A/D converter and four banks of memory. It features built-in support for PCI Express over the 3U VPX backplane.

The Cobalt Architecture

The Pentek Cobalt architecture features a Virtex-6 FPGA. All of the board’s data and control paths are accessible by the FPGA, enabling factory-installed functions including data multiplexing, channel selection, data packing, gating, triggering and memory control. The Cobalt architecture organizes the FPGA as a container for data processing applications where each function exists as an intellectual property (IP) module.

Each member of the Cobalt family is delivered with factory-installed applications ideally matched to the board’s analog interfaces. The 53641 factory-installed functions include an A/D acquisition IP module. In addition, IP modules for DDR3 memories, a controller for all data clocking and synchro-

nization functions, a test signal generator and a PCI interface complete the factory-installed functions and enable the 53641 to operate as a complete turnkey solution, without the need to develop any FPGA IP.

For applications that require additional control and status signals, option -104 provides 20 pairs of LVDS connections between the FPGA and the VPX P2 connector for custom I/O.

A/D Converter Stage

The front end accepts analog HF or IF inputs on a pair of front panel SSMC connectors with transformer coupling into a Texas Instruments ADC12D1800 12-bit A/D. The converter operates in single-channel interleaved mode with a sampling rate of 3.6 GHz and an input bandwidth of 1.75 GHz; or, in dual-channel mode with a sampling rate of 1.8 GHz and input bandwidth of 2.8 GHz.

The ADC12D1800 provides a programmable 15-bit gain adjustment allowing the 53641 to have a full scale input range of +2 dBm to +4 dBm. A built-in AutoSync feature supports A/D synchronization across multiple boards.

The A/D digital outputs are delivered into the Virtex-6 FPGA for signal processing, data capture or for routing to other module resources. ➤

Features

- Ideal radar and software radio interface solution
- One-channel mode with 3.6 GHz, 12-bit A/D
- Two-channel mode with 1.8 GHz, 12-bit A/Ds
- 2 GB of DDR3 SDRAM
- Programmable one- or two-channel DDC (Digital Downconverter)
- PCI Express (Gen. 1 & 2) interface, up to x8
- Sync bus for multiboard synchronization
- Optional LVDS connections to the Virtex-6 FPGA for custom I/O
- 3U VPX form factor provides a compact, rugged platform
- Compatible with several VITA standards including: VITA-46, VITA-48 and VITA-65 (OpenVPX™ System Specification)
- Ruggedized and conduction-cooled versions available

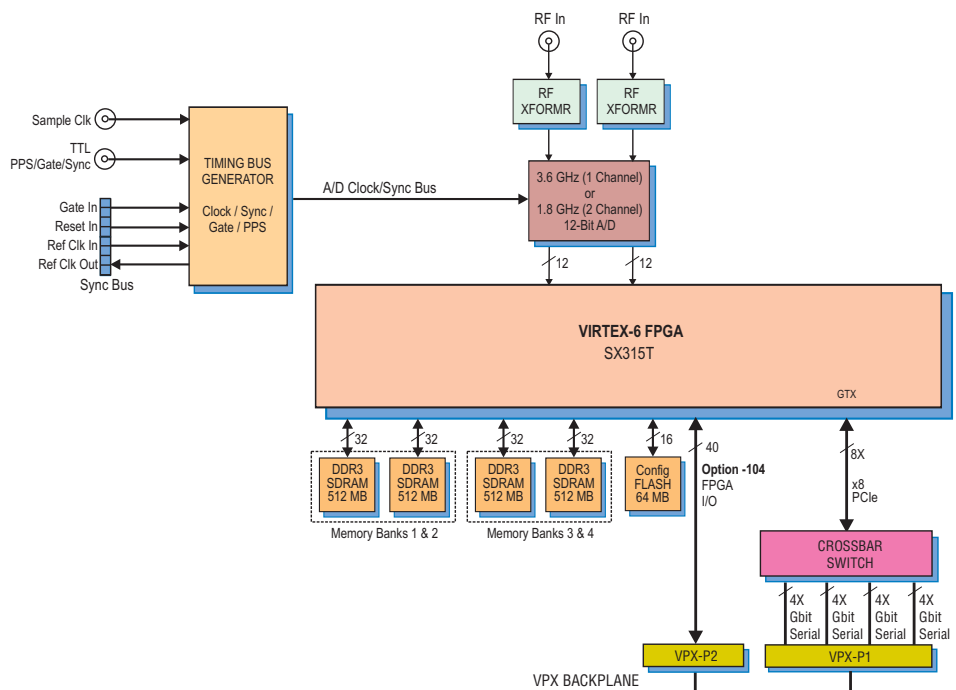

A/D Acquisition IP Module

The 53641 features an A/D Acquisition IP Module for easy capture and data moving. The IP module can receive data from the A/D, or a test signal generator. The IP module has associated memory banks for buffering data in FIFO mode or for storing data in transient capture mode. In single-channel mode, all four banks are used to store the single-channel of input data. In dual-channel mode, memory banks 1 and 2 store data from input channel 1 and memory banks 3 and 4 store data from input channel 2. In both modes, continuous, full-rate transient capture of 12-bit data is supported.

The memory banks are supported with a DMA engine for moving A/D data through the PCIe interface. This powerful linked-list DMA engine is capable of a unique Acquisition Gate Driven mode. In this mode, the length of a transfer performed by a link definition need not be known prior to data acquisition; rather, it is governed by the length of the acquisition gate. This is extremely useful in applications where an external gate drives acquisition and the exact length of that gate is not known or is likely to vary.

For each transfer, the DMA engine can automatically construct metadata packets containing a sample-accurate time stamp, and data length information. These actions simplify the host processor's job of identifying and executing on the data.

DDC IP Cores

Within the FPGA is a powerful DDC IP core. The core supports a single-channel mode, accepting data samples from the A/D at the full 3.6 GHz rate. Additionally, a dual-channel mode supports the A/D's 1.8 GHz two-channel operation.

In dual-channel mode, each DDC has an independent 32-bit tuning frequency setting that ranges from DC to f_s , where f_s is the A/D sampling frequency.

In single-channel mode, decimation can be programmed to 8x, 16x or 32x. In dual-channel mode, both channels share the same decimation rate, programmable to 4x, 8x or 16x.

The decimating filter for each DDC accepts a unique set of user-supplied 16-bit coefficients. The 80% default filters deliver an output bandwidth of $0.8 * f_s / N$, where N is the decimation setting. The rejection of adjacent-band components within the 80% output bandwidth is better than 100 dB. Each DDC delivers a complex output stream consisting of 16-bit I + 16-bit Q samples at a rate of f_s / N .

Clocking and Synchronization

The 53641 accepts a 1.8 GHz dual-edge sample clock via a front panel SSMC connector. A second front panel SSMC accepts a TTL signal that can function as Gate, PPS or Sync.

A front panel multipin sync bus connector allows multiple boards to be synchronized, ideal for larger multichannel systems. The sync bus includes gate, reset and in and out reference clock signals. Multiple 53641's can be synchronized using the Cobalt high-speed sync board to drive the sync bus.

Memory Resources

The 53641 architecture supports four independent memory banks of DDR3 SDRAM. Each bank is 512 MB deep and is an integral part of the board's DMA and data capture capabilities. Built-in memory functions include an A/D data transient capture mode for taking snapshots of data for transfer to a host computer. ➤

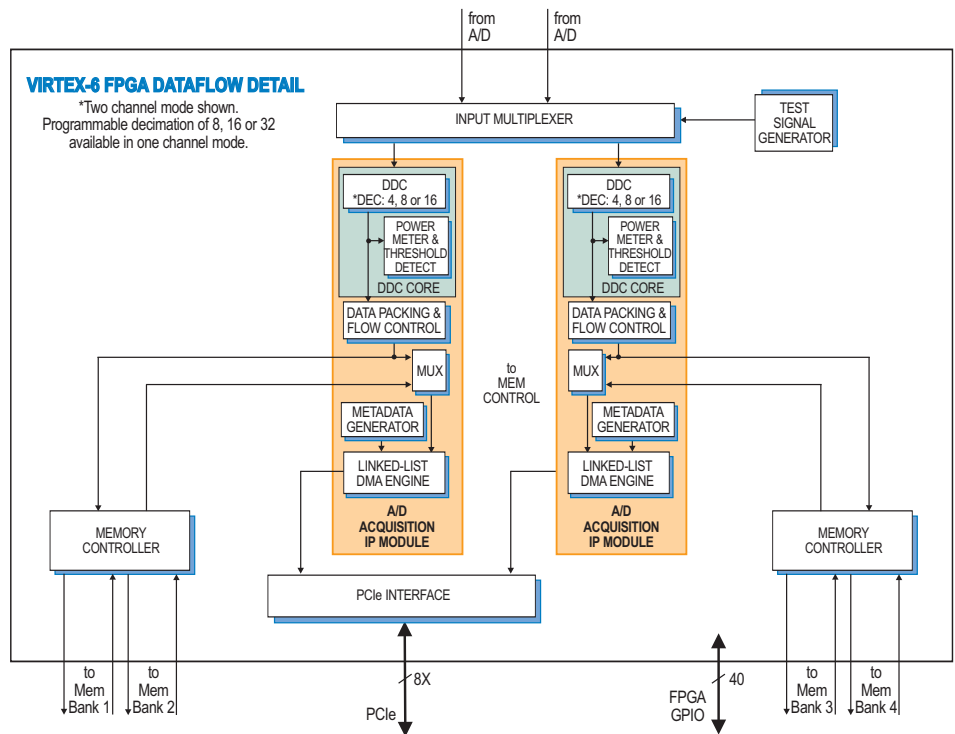

Model 8267

The Model 8267 is a fully-integrated development system for Pentek Cobalt, Onyx and Flexor 3U VPX boards. It was created to save engineers and system integrators the time and expense associated with building and testing a development system that ensures optimum performance of Pentek boards.



Ordering Information

Model	Description
53641	1-Ch. 3.6 GHz or 2-Ch. 1.8 GHz, 12-bit A/D, with Wideband DDC, Virtex-6 FPGA - 3U VPX

Options:

-002*	-2 FPGA speed grade
-064*	XC6VSX315T FPGA
-104	LVDS FPGA I/O to VPX P2
-155*	Two 512 MB DDR3 SDRAM Memory Banks (Banks 1 and 2)
-165*	Two 512 MB DDR3 SDRAM Memory Banks (Banks 3 and 4)

* These options are always required

Contact Pentek for availability of rugged and conduction-cooled versions

Model	Description
8267	VPX Development System. See 8267 Datasheet for Options

► PCI Express Interface

The Model 53641 includes an industry-standard interface fully compliant with PCI Express Gen. 1 & 2 bus specifications. Supporting PCIe links of x4 or x8, the interface includes multiple DMA controllers for efficient transfers to and from the board.

Fabric-Transparent Crossbar Switch

The 53641 features a unique high-speed switching configuration. A fabric-transparent crossbar switch bridges numerous interfaces and components on the board using gigabit serial data paths with no latency.

Programmable signal input equalization and output pre-emphasis settings enable optimization. Data paths can be selected as single (1X) lanes, or groups of four lanes (4X).

Specifications

Front Panel Analog Signal Inputs

Input Type: Transformer-coupled, front panel female SSMC connectors

A/D Converter

Type: Texas Instruments ADC12D1800

Sampling Rate: Single-channel mode: 500 MHz to 3.6 GHz; dual-channel mode: 150 MHz to 1.8 GHz

Resolution: 12 bits

Input Bandwidth: single-channel mode: 1.75 GHz; dual-channel mode: 2.8 GHz

Full Scale Input: +2 dBm to +4 dBm, programmable

Digital Downconverters

Modes: One or two channels, programmable

Supported Sample Rate: One-channel mode: 3.6 GHz, two-channel mode: 1.8 GHz

Decimation Range: One-channel mode: 8x, 16x or 32x, two-channel mode: 4x, 8x, or 16x

LO Tuning Freq. Resolution: 32 bits, 0 to f_s

LO SFDR: >120 dB

Phase Offset Resolution: 32 bits, 0 to 360 degrees

FIR Filter: User-programmable 18-bit coefficients

Default Filter Set: 80% bandwidth, <0.3 dB passband ripple, >100 dB stopband attenuation

Sample Clock Sources: Front panel SSMC connector

Sync Bus: Multipin connectors, bus includes gate, reset and in and out reference clock

External Trigger Input

Type: Front panel female SSMC connector, TTL

Function: Programmable functions include: trigger, gate, sync and PPS

Field Programmable Gate Array

Xilinx Virtex-6 XC6VSX315T-2

Custom I/O

Option -104: Provides 20 pairs of LVDS connections between the FPGA and the VPX P2 connector for custom I/O

Memory: Four 512 MB DDR3 SDRAM memory banks, 400 MHz DDR

PCI-Express Interface

PCI Express Bus: Gen. 1 or Gen. 2: x4 or x8

Environmental

Operating Temp: 0° to 50° C

Storage Temp: -20° to 90° C

Relative Humidity: 0 to 95%, non-cond.

Size: 3.937 in. x 6.717 in. (100 mm x 170.6 mm)

VPX Families

Pentek offers two families of 3U VPX products: the 53xxx and the 52xxx. For more information on a 52xxx product, please refer to the product datasheet. The table below provides a comparison of their main features.

VPX Family Comparison		
	52xxx	53xxx
Form Factor	3U VPX	
# of XMCs	One XMC	
Crossbar Switch	No	Yes
PCIe path	VPX P1	VPX P1 or P2
PCIe width	x4	x8
Option -104 path	20 pairs on VPX P2	
Option -105 path	Two x4 or one x8 on VPX P1	Two x4 or one x8 on VPX P1 or P2
Lowest Power	Yes	No
Lowest Price	Yes	No