



Model 52610 COTS (left) and rugged version



Features

- 32 bits of LVDS digital I/O
- One LVDS clock
- One LVDS data valid
- One LVDS data suspend
- Supports LXT and SXT Virtex-6 FPGAS
- DMA controller moves data to and from system memory
- Up to 2 GB of DDR3 SDRAM
- PCI Express interface
- Optional user-configurable gigabit serial interface
- Optional LVDS connections to the Virtex-6 FPGA for custom I/O to the carrier board
- 3U VPX form factor provides a compact, rugged platform
- Compatible with several VITA standards including: VITA-46, VITA-48 and VITA-65 (OpenVPX™ System Specification)
- Ruggedized and conduction-cooled versions available

General Information

Model 53610 is a member of the Cobalt® family of high-performance 3U VPX boards based on the Xilinx Virtex-6 FPGA. This digital I/O board provides 32 LVDS differential inputs or outputs plus LVDS clock, data valid, and data flow control on a front panel 80-pin connector. Its built-in data capture and data generation feature offers an ideal turnkey solution as well as a platform for developing and deploying custom FPGA-processing IP.

In addition to supporting PCI Express Gen. 1 as a native interface, the Model 53610 includes a general-purpose connector for application-specific I/O.

The Cobalt Architecture

The Pentek Cobalt Architecture features a Virtex-6 FPGA. All of the board's data and control paths are accessible by the FPGA, enabling factory-installed functions for data flow and memory control. The Cobalt Architecture organizes the FPGA as a container for data processing applications where each function exists as an IP (intellectual property) module.

Each member of the Cobalt family is delivered with factory-installed applications ideally matched to the board's interface. The 53610 factory-installed functions include 32-bit acquisition and generation IP modules, to support either input or output functions, respectively.

IP modules for DDR3 SDRAM memories, a controller for all data clocking, a test

signal generator, and a PCIe interface complete the factory-installed functions and enable the 53610 to operate as a complete turnkey solution without the need to develop any FPGA IP.

Extendable IP Design

For applications that require specialized function, users can install their own custom IP for data processing. Pentek GateFlow FPGA Design Kits include all of the factory-installed modules as documented source code. Developers can integrate their own IP with the Pentek factory-installed functions or use the GateFlow kit to completely replace the Pentek IP with their own.

Xilinx Virtex-6 FPGA

The Virtex-6 FPGA can be populated with a variety of different FPGAs to match the specific requirements of the processing task. Supported FPGAs include: LX130T LX240T, or SX315T. The SXT part features up to 1344 DSP48E slices and is ideal for modulation/demodulation, encoding/decoding, encryption/decryption, and channelization of the signals between transmission and reception. For applications not requiring large DSP resources, one of the lower-cost LXT FPGAs can be installed.

Option -104 provides 20 pairs of LVDS connections between the FPGA and the VPX P2 connector for custom I/O.

Option -105 provides one 8X or two 4X gigabit links between the FPGA and the VPX P1 connector to support serial protocols. ➤

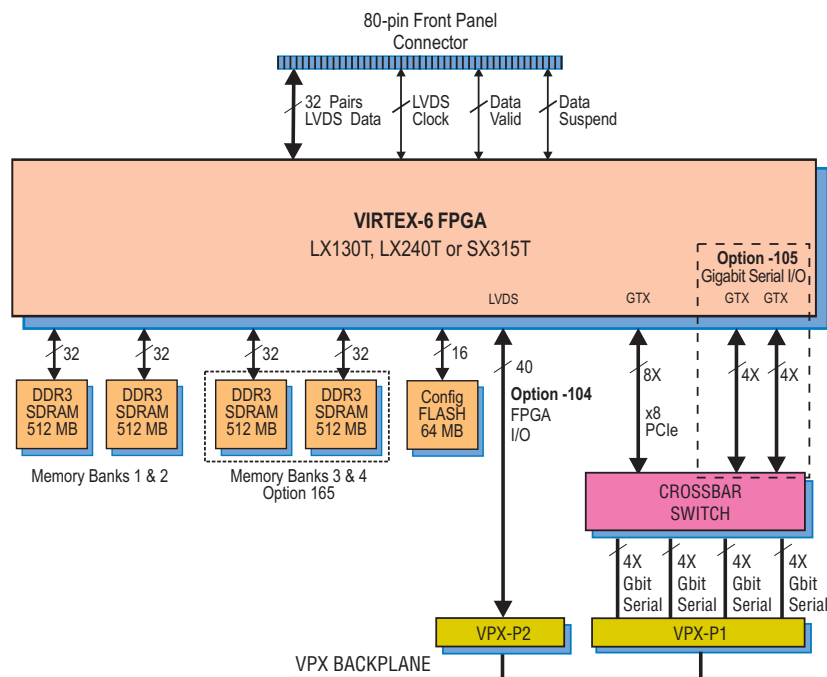

Fabric-Transparent Crossbar Switch

The 53610 features a unique high-speed switching configuration. A fabric-transparent crossbar switch bridges numerous interfaces and components on the board using gigabit serial data paths with no latency. Programmable signal input equalization and output pre-emphasis settings enable optimization. Data paths can be selected as single (1X) lanes, or groups of four lanes (4X).

Model 8267

The Model 8267 is a fully-integrated development system for Pentek Cobalt, Onyx and Flexor 3U VPX boards. It was created to save engineers and system integrators the time and expense associated with building and testing a development system that ensures optimum performance of Pentek boards.



Ordering Information

Model Description

53610 LVDS Digital I/O with Virtex-6 FPGA - 3U VPX

Options:

- 062 XC6VLX240T
- 064 XC6V SX315T
- 104 LVDS FPGA I/O to VPX P2
- 105 Gigabit serial FPGA I/O to VPX P1
- 155* Two 512 MB DDR3 SDRAM Memory Banks (Banks 1 and 2)
- 165 Two 512 MB DDR3 SDRAM Memory Banks (Banks 3 and 4)

* This option is always required

Contact Pentek for availability of rugged and conduction-cooled versions

Model	Description
8267	VPX Development System See 8267 Datasheet for Options

► Acquisition IP Module

The board can be configured for digital input mode by the setting of a jumper. In this case, the board accepts input data Clock and input data Valid signals. This supports a continuous input Clock with data accepted only when the Data Valid line is true. The board can optionally generate a Data Suspend output signal indicating that the 53610 is no longer capable of accepting data. The board accepts 32 bits from the front panel connector or from an on-board test signal generator.

Each IP module has an associated memory bank for buffering data in FIFO mode or for storing data in transient capture mode. Memory banks are supported with DMA engines for easily moving input data through the PCIe interface.

Generation IP Module

The board can be configured for digital output mode by the setting of a jumper. In this case, the board generates output data Clock and output Data Valid signals. This supports a continuous output Clock with data valid only when the Data Valid line is true. The board can optionally accept a Data Suspend input signal to halt data generation when the destination device is no longer capable of accepting data.

A linked-list controller allows users to generate 32-bit digital words out through the front panel LVDS connector from tables stored in either on-board or off-board host memory. Parameters including length of table, delay from software trigger, table repetition, etc. can be programmed for entry. Up to 64 individual link entries can be chained together to create complex output patterns with minimum programming.

PCI Express Interface

The Model 53610 includes an industry-standard interface fully compliant with PCI Express Gen. 1 bus specifications. Supporting a PCIe x4 or x8 connection, the interface includes multiple DMA controllers for efficient transfers to and from the board.

Memory Resources

The 53610 hardware architecture supports up to four independent 512 MB memory banks of DDR3 SDRAM. The board is always configured with 1 GB of memory (Banks 1 and 2).

In addition to the factory-installed functions, custom user-installed IP within the FPGA can take advantage of the memories for many other purposes. For customers who need more memory to support their

IP, Banks 3 and 4 can be optionally added for a total of 2 GB of DDR3 SDRAM

Specifications

Front Panel Input/Output

Data Lines: 35 LVDS differential pairs (32 pairs supported in factory-installed functions), 2.5 V compliant

Clock: One LVDS differential pair, 2.5 V compliant

Data Valid: One LVDS differential pair, 2.5 V compliant

Data Suspend: One LVDS differential pair, 2.5 V compliant

Field Programmable Gate Array

Standard: Xilinx Virtex-6 XC6VLX130T

Optional: Xilinx Virtex-6 XC6VLX240T, or XC6V SX315T

Custom I/O

Option -104: Provides 20 pairs of LVDS connections between the FPGA and the VPX P2 connector for custom I/O.

Option -105: Provides one 8X or two 4X gigabit links between the FPGA and the VPX P1 connector to support serial protocols.

Memory

Standard: Two 512 MB DDR3 SDRAM memory banks (1 and 2), 400 MHz DDR

Option 165: Two 512 MB DDR3 SDRAM memory banks (3 and 4), 400 MHz DDR

PCI-Express Interface

PCI Express Bus: Gen. 1: x4 or x8

Environmental

Operating Temp: 0° to 50° C

Storage Temp: -20° to 90° C

Relative Humidity: 0 to 95%, non-cond.

Size: 3.937 in. x 6.717 in. (100 mm x 170.6 mm)

VPX Families

Pentek offers two families of 3U VPX products: the 52xxx and the 53xxx. For more information on a 52xxx product, please refer to the product datasheet. The table below provides a comparison of their main features.

	VPX Family Comparison	
	52xxx	53xxx
Form Factor	3U VPX	
# of XMCs	One XMC	
Crossbar Switch	No	Yes
PCIe path	VPX P1	VPX P1 or P2
PCIe width	x4	x8
Option -104 path	20 pairs on VPX P2	
Option -105 path	Two x4 or one x8 on VPX P1	Two x4 or one x8 on VPX P1 or P2
Lowest Power	Yes	No
Lowest Price	Yes	No