

February 2011

Feature Article

Harnessing FPGAs for Beamforming Software Radio Systems

Over the past 20 years, software defined radio techniques have not only revolutionized radar and communications systems, but they have also boosted system performance levels. One of the most widely-deployed and technically challenging operations in these systems is beamforming.

Resource	Virtex-4	Virtex-5	Virtex-6
Logic Cells	41K – 152K	46K – 156K	128K – 476K
Slices	18K – 68K	7K – 24K	20K – 74K
Block RAM (kbits)	1728 – 6768	2160 – 8784	9504 – 35304
DSP Slices	64 – 512	48 – 640	480 – 2016
Gigabit Serial Transceivers	0 – 20	12 – 16	20
User I/O Pins	448 – 768	480 – 640	600

Figure 1. Range of FPGA resources within a 35mm square Xilinx device package.

Beamforming is a signal processing technique that utilizes an array of sensors to achieve directionality, increase the strength of transmitted signals and improve the quality of received signals. Beamforming applications span frequencies from sub-audio to light, and encompass a diverse range of critical applications for commerce, industry, government and defense. Systems developers are continuously exploiting new technology to boost performance for specific applications, with significant emphasis on communications and signals intelligence.

Beamforming: Principles and Benefits

For software radio systems, the beamforming sensors are transmit and receive antennas. For receiver systems, the signal arrival delay at each antenna is directly proportional to the path distance from the source. The beamforming process adjusts the gain and phase of each antenna signal to cancel the delay path differences for signals arriving from a particular direction. Aligned signals are then summed together to produce high signal-to-noise reception in the chosen direction.

By adjusting gain and phase in each path, the antenna is electronically “steered” without the need for moving mechanical structures. Examples of software radio applications that use beamforming include direction finding, in which a beamformed antenna can be steered to locate the arrival angle of a signal source. Two or more arrays can be used to triangulate the exact location of the source, which is essential for many signal intelligence and counter terrorism efforts.

In addition to directionality, beamforming also improves reception in so-called “diversity receivers”. The combined signal from multiple antennas boosts the signal-to-noise ratio compared to a single antenna, thus extending the operational range of the receiver system.

Missile detection and countermeasure applications use beamforming to improve tracking of an object allowing for early detection and improved responsiveness. With no moving mechanisms, airborne arrays take full advantage of electronic steering to dramatically improve the range and target resolution. And lastly, beamforming allows spatial frequency sharing for commercial mobile phone carriers by dividing one cell into several beamformed pie-slice sectors that can share the same frequency.

FPGAs — Ideal Beamforming Engines

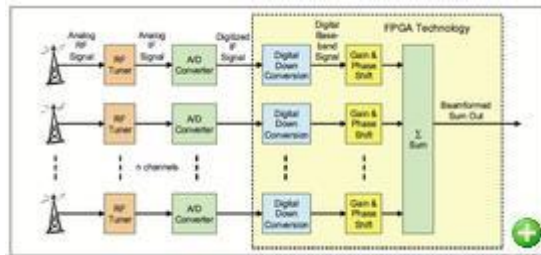

Figure 2. Software defined radio system for beamforming using FPGA technology.

Each new generation of FPGA delivers new features, higher levels of performance, and reduced power consumption for a given function. The Virtex-6 Series of FPGAs from Xilinx represent a major step, featuring 40 nm silicon technology, over 2000 DSP engines, serial gigabit transceivers with rates up to 11 GHz, fast PCI Express (PCIe) end points, and over 750,000 logic cells.

Because they can implement extreme parallelism with hundreds of DSP blocks operating in parallel, FPGAs are best suited for processing-intensive digital signal processing algorithms, especially like those found in beamforming applications.

Unlike FPGAs, general purpose programmable RISC or DSP processors have a finite set of multipliers, adders, and shift registers in the ALU which must be operated sequentially for each sample. As a result, earlier beamforming systems using RISC and DSP processors have been largely eclipsed by newer FPGA-based designs.

The key signal processing elements for beamforming include digital down conversion, phase and gain adjustments, and summation, all handled by the DSP engines. The PCIe interface provides a fast interface to the system controller for initialization and delivery of beamforming coefficients for gain and phase shifts. The gigabit serial links also can be extremely useful in propagating the beamformed summation across multiple boards for high channel count systems. Lastly, the configurable logic supports timing synchronization across the channels and data formatting.

Figure 1 compares the Virtex-6 family to the two earlier generations of Xilinx FPGAs, showing the quantity of key resources contained in a 35 mm square package of each generation. The range of numbers in each block covers the densities of different FPGA devices offered in that package.

Compared to the Virtex-5, the largest Virtex-6 device triples the number of logic cells and DSP slices. This represents a much larger relative jump in resources compared to the Virtex-4 to Virtex-5

transition. For this reason, the new Virtex-6 technology leverages a significant boost in both performance and capability, especially for software radio applications.

SDR Operations for Beamforming

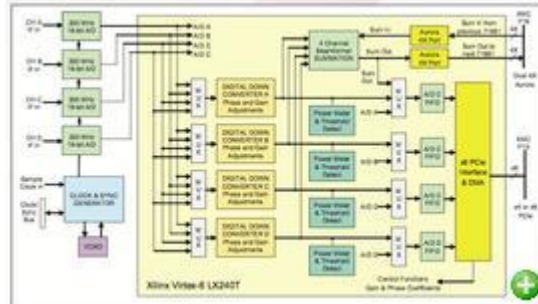

Figure 3. Pentek Model 71661 4-channel 200 MHz 16-bit A/D beamforming module.

Figure 2 shows the basic signal processing tasks required for beamforming. The RF signals from the antenna must first be amplified and translated to an IF (intermediate frequency) signal to permit digitization by the A/D converter. Popular IF frequencies range from 21.4 to 160 MHz and many A/D converters now handle these signals with sampling rates between 80 and 500 Msamples/sec. These high-speed A/D converters connect directly to FPGAs with high speed LVDS interfaces supporting data converter peripherals operating at sample rates to 600 MHz and higher.

The next task is digital downconversion of the IF signal to baseband, producing a complex (I+Q) signal centered at DC or 0 Hz. In addition, the downconverted baseband signal is low-pass filtered to allow only the signal of interest to appear at the output. Together, these operations represent the classic software radio function — the DDC.

Inside the DDC, the frequency translation to baseband is performed by mixing the digital A/D input signal with digital samples from a numerically controlled local oscillator (NCO). The mixer employs two multipliers from the FPGA DSP blocks to handle the real A/D samples and the complex NCO samples.

The NCO is a phase accumulator (also part of the DSP block) followed by a sine look-up table. The table converts the steadily advancing phase value to sine wave samples. The NCO frequency is programmable by the operator to produce any frequency from DC to the A/D sample clock frequency. The complex baseband signal at the mixer output is fed into a low pass filter using DSP block multipliers, registers and adders. It features programmable filter coefficients to set the signal channel bandwidth.

Special circuitry incorporated in the NCO allows the user to offset the phase accumulator by a programmable angle to implement the phase shift requirement for beamforming. The gain adjustment is performed using a DSP block multiplier. Finally, the adjusted outputs of each DDC are summed together, again taking advantage of adders in the DSP blocks.

Beamforming Software Radio Module

A/D conversion plus all beamforming DSP operations for up to four channels can be handled in Pentek's Model 71661 Software Radio Beamformer XMC module. As shown in Figure 3, it features

four 200 MHz 16-bit A/D converters for digitizing the IF signals and a Virtex-6 LX240T FPGA for virtually all module functions, including the real-time beamforming software radio tasks.

Inside the FPGA are four digital downconverters (DDCs) which also incorporate the phase shift and gain adjustments. Each DDC can select from any of four A/D inputs to support different ratios of antennas to signal channels. Four power meters at each DDC output allow measurement of output power to help calibrate the gain settings for beamforming.

The Model 71661 also includes a summation block that adds the DDC outputs to form a four-channel beamforming sum. This block also accepts a propagated “sum in” signal from another module and generates a propagated “sum out” signal to the next module. The sum in and sum out signals use two X4 Aurora gigabit serial links connected through the P16 XMC connector, and each link is capable of moving data at 1.25 GB/sec peak. The final sum can be directed through the PCIe interface to the system CPU.

A clock and sync generator block accepts an external 5 or 10 MHz reference input to drive a phase-locked A/D sample clock synthesizer. A multi-pin LVPECL front panel connector supports synchronous sampling across multiple modules, which is an essential and critical requirement for all types of beamforming systems. The x4 or x8 PCIe interface operating at Gen 1 or Gen 2 speeds completes the link to the host processor, operating at peak transfer rates of up to 4 GB/sec.

Summary

Each new generation of FPGA opens up new classes of applications that were impractical with previous technology. The role of the FPGA in today’s software radio systems is so pervasive because it encompasses so many essential operations. As evidenced by the design of the 71661 module, virtually every device on the module connects to the FPGA.

For beamforming, FPGA functions include digital downconversion, synchronization and timing, phase and gain adjustments, power measurement, summation, gigabit serial links for summation propagation, the PCIe system interface for control, and high speed interfaces to A/Ds and other peripheral devices. As FPGA devices evolve, each of the key resources supporting these critical operations will be enhanced in performance and numbers, dictated by the importance of each to mainstream applications like software radio beamforming.

This article was written by Rodger Hosking, Vice President, Pentek, Inc., Upper Saddle River, NJ. For more information, visit <http://info.hotims.com/34451-527>.

<http://www.techbriefs.com/component/content/article/9204>