

New!

Models 57730 & 58730

1- or 2-Channel 1 GHz A/D, 1- or 2-Channel 1 GHz D/A with Virtex-7 FPGA - 6U OpenVPX



Model 58730



General Information

Models 57730 and 58730 are members of the Onyx® family of high-performance 6U OpenVPX boards based on the Xilinx Virtex-7 FPGA. They consist of one or two Model 71730 XMC modules mounted on a VPX carrier board.

Model 57730 is a 6U board with one Model 71730 module while the Model 58730 is a 6U board with two XMC modules rather than one.

These models include one or two 1 GHz A/D and D/A converters and four or eight banks of memory

The Onyx Architecture

The Pentek Onyx Architecture features Virtex-7 FPGAs. All of the board's data and control paths are accessible by the FPGA, enabling factory-installed functions including data multiplexing, channel selection, data packing, gating, triggering and memory control. The Onyx Architecture organizes the FPGA as a container for data processing applications where each function exists as an intellectual property (IP) module.

Each member of the Onyx family is delivered with factory-installed applications ideally matched to the board's analog interfaces. The factory-installed functions of these models include one or two A/D acquisition and one or two D/A waveform playback IP modules for simplifying data capture and data transfer.

IP modules for DDR3 SDRAM memories, controllers for all data clocking and synchronization functions, test signal generators,

and a PCIe interface complete the factory-installed functions and enable these models to operate as complete turnkey solutions without the need to develop FPGA IP.

Extendable IP Design

For applications that require specialized functions, users can install their own custom IP for data processing. Pentek GateFlow FPGA Design Kits include all of the factory installed modules as documented source code. Developers can integrate their own IP with the Pentek factory-installed functions or use the GateFlow Design Kit to completely replace the Pentek IP with their own.

Xilinx Virtex-7 FPGA

The Virtex-7 FPGA site can be populated with one of two FPGAs to match the specific requirements of the processing task. Supported FPGAs are VX330T or VX690T. The VX690T features 3600 DSP48E1 slices and is ideal for modulation/demodulation, encoding/decoding, encryption/decryption, and channelization of the signals between transmission and reception. For applications not requiring large DSP resources or logic, the lower-cost VX330T can be installed.

Option -104 provides 24 LVDS pairs between the FPGA and the VPX P3 connector, Model 57730; P3 and P5, Model 58730.

Option -105 supports serial protocols by providing a 4X gigabit link between the FPGA and VPX P2, Model 57730; or one 4X link from each FPGA to P2 and an additional 4X link between the FPGAs, Model 58730. ▶

Features

- Supports Xilinx Virtex-7 VXT FPGAs
- GateXpress supports dynamic FPGA reconfiguration across PCIe
- One or two 1 GHz 12-bit A/D
- One or two 1 GHz 16-bit D/A
- 4 or 8 GB of DDR3 SDRAM
- Sample clock synchronization to an external system reference
- PCI Express (Gen. 1, 2 & 3) interface up to x8
- Dual-µSync clock/sync bus for multiboard synchronization
- Optional user-configurable gigabit serial interface
- Optional LVDS connections to the Virtex-7 FPGA for custom I/O
- Ruggedized and conduction-cooled versions available

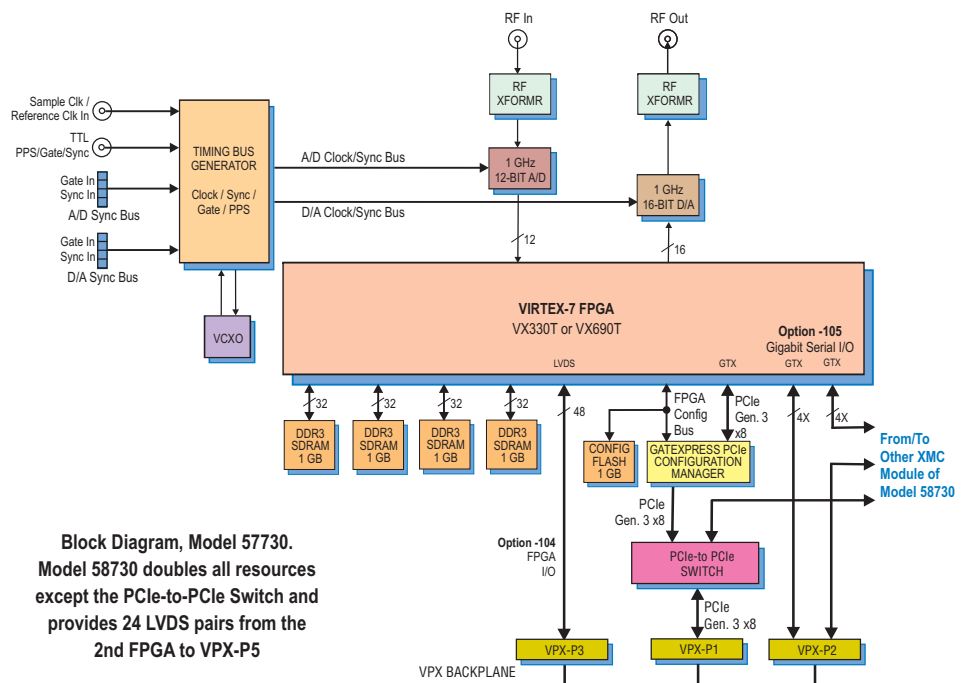

A/D Acquisition IP Module

These models feature one or two A/D Acquisition IP Modules for easy capture and data moving. The IP module can receive data from the A/D, a test signal generator, or from the D/A Waveform Playback IP Module in loopback mode. The IP module has associated memory banks for buffering data in FIFO mode or for storing data in transient capture mode. The memory banks are supported with a DMA engine for moving A/D data through the PCIe interface.

This powerful linked-list DMA engine is capable of a unique Acquisition Gate Driven mode. In this mode, the length of a transfer performed by a link definition need not be known prior to data acquisition; rather, it is governed by the length of the acquisition gate. This is extremely useful in applications where an external gate drives acquisition and the exact length of that gate is not known or is likely to vary.

For each transfer, the DMA engine can automatically construct metadata packets containing a sample-accurate time stamp, and data length information. These actions simplify the host processor's job of identifying and executing on the data.

D/A Waveform Playback IP Modules

The factory-installed functions include one or two sophisticated D/A Waveform Playback IP modules. A linked-list controller allows users to easily play back waveforms stored in either on-board memory or off-board host memory to the D/A.

Parameters including length of waveform, delay from playback trigger, waveform repetition, etc. can be programmed for each waveform.

Up to 64 or 128 individual link entries can be chained together to create complex waveforms with a minimum of programming.

► GateXpress for FPGA Configuration

The Onyx architecture includes GateXpress, a sophisticated FPGA-PCIe configuration manager for loading and reloading the FPGAs. At power-up, GateXpress immediately presents a target for the host computer to discover, effectively giving the FPGAs time to load from FLASH. This is especially important for larger FPGAs where the loading times can exceed the PCIe discovery window, typically 100 msec on most PCs.

The board's configuration FLASH can hold four FPGA images. Images can be factory-installed IP or custom IP created by the user. In this case, it's programmed into the FLASH via JTAG using Xilinx iMPACT or through the board's PCIe interface. At power-up the user can choose which image to load based on a hardware switch setting.

Once booted, GateXpress allows the user three options for dynamically reconfiguring the FPGAs with new IP images. The first option is to load an alternate image from FLASH through software control. The user selects the desired image and issues a reload command.

The second option is for applications where the FPGA image must be loaded directly through the PCIe interface. This is important in security situations where there can be no latent user image left in nonvolatile memory when power is removed. In applications where the FPGA IP may need to change many times during the course of a mission, images can be stored on the host computer and loaded as needed.

The third option, typically used during development, allows the user to directly load the FPGAs through JTAG using Xilinx iMPACT.

In all three FPGA-loading scenarios, GateXpress handles the hardware negotiation thereby simplifying and streamlining the loading task. In addition, GateXpress preserves the PCIe configuration space allowing dynamic FPGA reconfiguration without the need to reset the host computer so it can rediscover the board. After the reload, the host computer simply continues to see the board with the expected device ID.

A/D Converter Stages

The front end accepts one or two analog HF or IF inputs on front panel SSMC connectors with transformer coupling into one or two Texas Instruments ADS5400 1 GHz, 12-bit A/D converters.

The digital outputs are delivered into the Virtex-7 FPGAs for signal processing, data capture or for routing to other board resources.

D/A Converter Stages

These models feature one or two TI DAC5681Z 1 GHz, 16-bit D/As. The converters have an input sample rate of 1 GSps, allowing them to accept full rate data from the FPGA. Additionally, the D/As include a 2x or 4x interpolation filter for applications that provide 1/2- or 1/4-rate input data. Analog output is through front panel SSMC connectors. ►

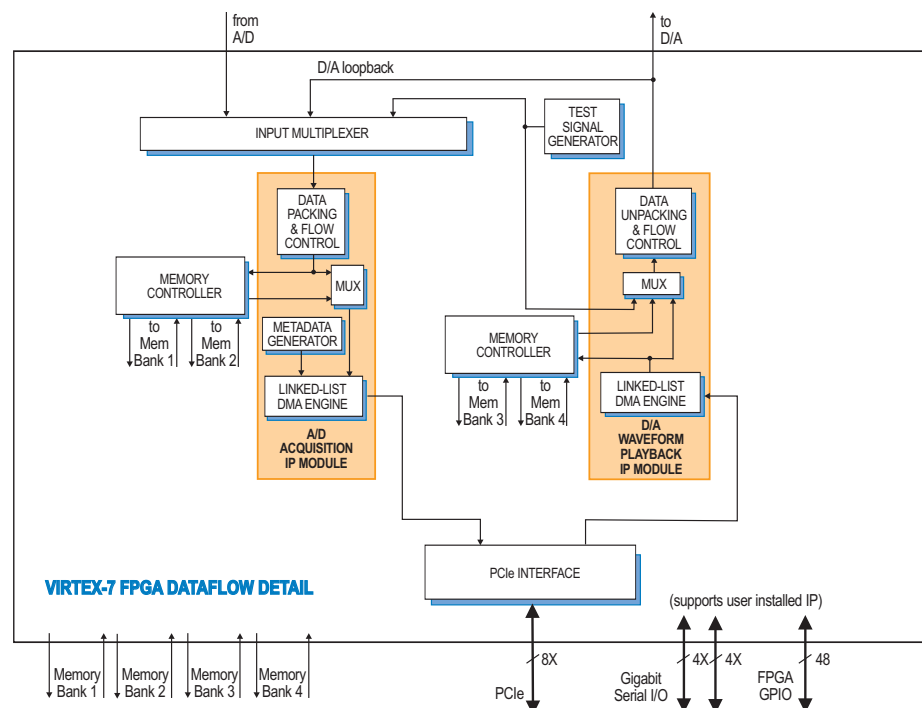

PCI Express Interface

These models include an industry-standard interface fully compliant with PCI Express Gen. 1, 2 and 3 bus specifications. Supporting PCIe links up to x8, the interface includes multiple DMA controllers for efficient transfers to and from the board.

Ordering Information

Model	Description
57730	1 GHz A/D and D/A with Virtex-7 FPGA - 6U VPX
58730	Two 1 GHz A/Ds and D/As, with two Virtex-7 FPGAs - 6U VPX
Options:	
-076	XC7VX690T-2 FPGA
-104	LVDS I/O between the FPGA and P3 connector, Model 57730; P3 and P5 connectors, Model 58730
-105	Gigabit link between the FPGA and P2 connector, Model 57730; gigabit links from each FPGA to P2 connector, Model 58730

Contact Pentek for availability of rugged and conduction-cooled versions

Clocking and Synchronization

Two internal timing buses provide either a single clock or two different clock rates to the A/D and D/A signal paths.

Each timing bus includes a clock, sync and a gate or trigger signal. An on-board clock generator receives a sample clock either from the front panel SSMC connector or from an on-board programmable VCXO (Voltage-Controlled Crystal Oscillator). In this latter mode, the front panel SSMC connector can be used to provide a 10 MHz reference clock to phase-lock the VCXO. Either clock source (front panel or VCXO) can be used directly or can be divided independently by 2, 4, 8, or 16 to provide different lower frequency A/D and D/A clocks.

A pair of front panel μ Sync connectors allows multiple boards to be synchronized. They accept CML inputs that drive the board's sync and gate/trigger signals.

The Pentek Model 9192 Cobalt or Onyx Synchronizer can drive multiple μ Sync connectors enabling large, multichannel synchronous configurations. Also, an LVTTTL external gate/trigger input is accepted on a front panel SSMC connector.

Memory Resources

The Onyx architecture supports four or eight independent DDR3 SDRAM memory banks. Each bank is 1 GB deep and is an integral part of the board's DMA capabilities, providing FIFO memory space for creating DMA packets. Built-in memory functions include multichannel A/D data capture, tagging and streaming.

In addition to the factory-installed functions, custom user-installed IP within the FPGA can take advantage of the memories for many other purposes.

Specifications

Model 57730: 1 A/D, 1 D/A

Model 58730: 2 A/Ds, 2 D/As

Front Panel Analog Signal Inputs (1 or 2)

Input Type: Transformer-coupled, front panel female SSMC connectors

A/D Converters (1 or 2)

Type: Texas Instruments ADS5400

Sampling Rate: 100 MHz to 1 GHz

Resolution: 12 bits

D/A Converters (1 or 2)

Type: Texas Instruments DAC5681Z

Input Data Rate: 1 GHz max.

Interpolation Filter: bypass, 2x or 4x

Output Sampling Rate: 1 GHz max.

Resolution: 16 bits

Front Panel Analog Signal Outputs (1 or 2)

Output Type: Transformer-coupled, front panel female SSMC connectors

Sample Clock Sources (1 or 2)

On-board clock synthesizer generates two clocks: one A/D clock and one D/A clock

Clock Synthesizers (1 or 2)

Clock Source: Selectable from on-board programmable VCXO or front panel external clock

VCXO Frequency Ranges: 10 to 945 MHz, 970 to 1134 MHz, and 1213 to 1417 MHz

Synchronization: VCXO can be phase-locked to an external 4 to 200 MHz system reference, typically 10 MHz

Clock Dividers: External clock or VCXO can be divided by 1, 2, 4, 8, or 16, independently for the A/D clock and D/A clock

External Clocks (1 or 2)

Type: Front panel female SSMC connector, sine wave, 0 to +10 dBm, AC-coupled, 50 ohms, accepts 100 MHz to 1 GHz divider input clock, or PLL system reference

Timing Bus (1 or 2): 19-pin μ Sync bus connector includes sync and gate/trigger inputs, CML

External Trigger Input

Type: Front panel female SSMC connector, LVTTTL

Function: Programmable functions include: trigger, gate, sync and PPS

Field Programmable Gate Arrays (1 or 2)

Standard: Xilinx Virtex-7 XC7VX330T-2

Optional: Xilinx Virtex-7 XC7VX690T-2

Custom I/O (1 or 2)

Option -104: Provides 24 LVDS pairs between the FPGA and the VPX P3 connector, Model 57730; P3 and P5, Model 58730

Option -105: Supports serial protocols by providing a 4X gigabit link between the FPGA and VPX P2, Model 57730; or one 4X link from each FPGA to P2 and an additional 4X link between the FPGAs, Model 58730

Memory Banks (4 or 8)

Type: DDR3 SDRAM

Size: 1 GB each

Speed: 800 MHz (1600 MHz DDR)

PCI-Express Interface

PCI Express Bus: Gen. 1, 2 or 3: x4 or x8

Environmental: Level L1 & L2 air-cooled;

Level L3 ruggedized, conduction-cooled

Size: 3.937 in. x 6.717 in. (100 mm x 170.6 mm)