

New!

Models 7253, 7253D and 7353

4/8-Ch. DDC, 4/8 200 MHz 16-bit A/Ds, Beamformer - cPCI



Model 7353 Model 7253D

Features

- Built-in Beamformer supports multiboard systems
- Programmable Power Meter and Threshold Detect per channel
- 6U and 3U cPCI boards
- 2 or 4 (Models 7253 and 7353) and 4 or 8 (Model 7253D) channels of DDC
- Four or eight 200 MHz, 16-bit A/Ds
- Independent 32-bit DDC tuning for all channels
- DDC decimation range from 2 to 256 or from 2 to 65536
- LVPECL clock/sync bus for multiboard synchronization

General Information

Models 7253 and 7353 are high-speed software radio boards designed for processing baseband RF or IF signals from a communications receiver. They feature four 200 MHz 16-bit A/Ds (Models 7253 and 7353) or eight A/Ds (Model 7253D). Each group of four A/Ds is supported by a high-performance 4-channel installed DDC and a complete set of beamforming functions. With built-in multiboard synchronization, they are ideally matched to the requirements of real-time software radio and radar systems.

Model 7253 is a 6U cPCI board while Model 7353 is a 3U cPCI board. Model 7253D is the same as the 7253 except it provides twice the resources.

A/D Converter Stage

The front end accepts four or eight full-scale analog RF or IF inputs on front panel SMC connectors at +8 dBm into 50 ohms with transformer coupling into four or eight Texas Instruments ADS5485 200 MHz, 16-bit A/D converters. The digital outputs are delivered into Xilinx Virtex-5 FPGAs for routing, formatting and signal processing.

DDC Input Selection and Tuning

These Models employ an advanced FPGA-based digital downconverter engine consisting of two or four DDC channels. Four independently controllable input multiplexers select one of the four A/Ds as the input source for each DDC channel. In this way, many different configurations can be

achieved including one A/D driving all four DDC channels and each of the four A/Ds driving its own DDC bank.

Each of the DDC channels has an independent 32-bit tuning frequency setting that ranges from DC to f_s , where f_s is the A/D sampling frequency.

Decimation and Filtering

Each of the four DDC channels can have its own unique decimation setting, supporting as many as four different output bandwidths for the board. The DDC core can be configured in four-channel mode with each channel offering decimations between 2 and 256, or in two-channel mode with each channel having a decimation range of 2 to 65536, for applications that require a wider range of decimations.

The decimating filter for each DDC channel accepts a unique set of user-supplied 18-bit coefficients. The 80% default filters deliver an output bandwidth of $0.8 \cdot f_s / N$, where N is the decimation setting. The rejection of adjacent-band components within the 80% output bandwidth is better than 100 dB. Each DDC delivers a complex output stream consisting of 24-bit I + 24-bit Q samples at a rate of f_s / N .

Power Meters

Each DDC includes a power meter that continuously measures the individual average power output. The power meters calculate and present average power measurements for each channel in easy-to-read registers. The time constant of the averaging interval for each meter is programmable up to 8 kilosamples. Threshold detectors can generate interrupts when the ➤



Model 7253 and 7353 Block Diagram Model 7253D doubles all resources except the PCI Bridge

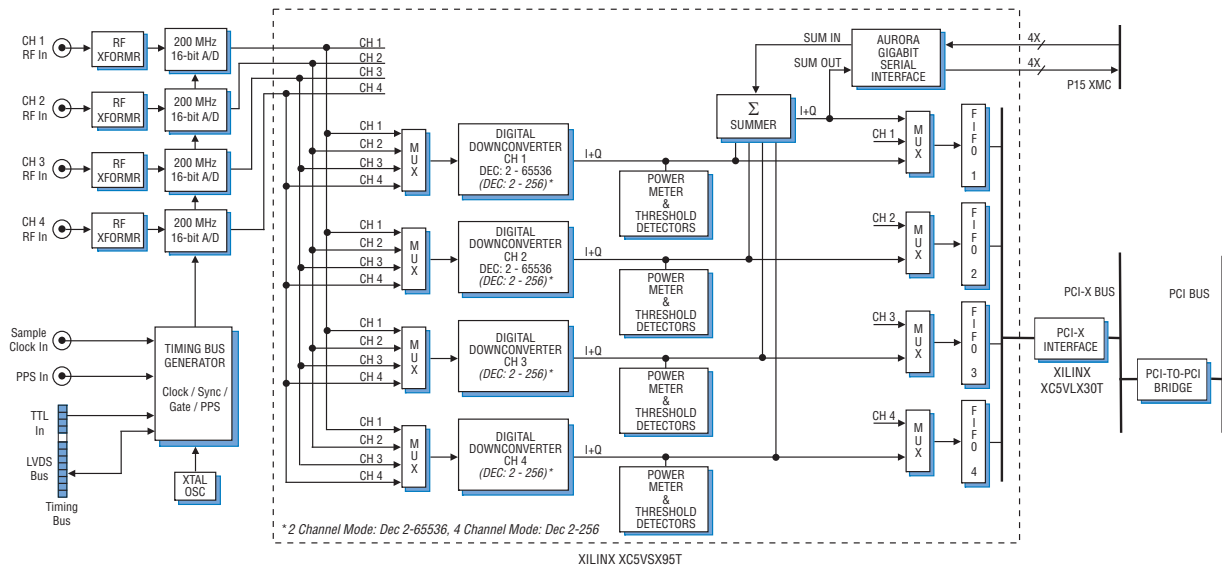

► calculated power levels exceed or fall below user-programmable thresholds, ideal for scanning and monitoring applications.

Beamformer

In addition to the A/Ds and DDCs, these Models include essential resources of a complete beamforming subsystem. First, each DDC channel provides user-programmable I & Q phase and gain adjustments to apply beamforming weights. Then, a summation block adds the four DDC output channels.

An additional programmable-gain stage compensates for summation bit growth. A power meter and threshold detect block is provided for the sum output. The sum output is then delivered to the Channel 1 FIFO for delivery through the PCI bus.

For larger systems, multiple Models can be chained together using a built-in Xilinx Aurora engine. It accepts an x4 gigabit sum input stream from a previous board and propagates an x4 sum output stream to the next board through the P15 XMC connector.

Output Multiplexers and FIFOs

Four output MUXs can be independently switched to deliver either A/D data or DDC data into each of the four output FIFOs. This allows users to view either the wideband A/D data or the narrowband DDC data, depending on the application.

Each of the output FIFOs operates at its own input rate and output rate to support different DDC decimation settings between the banks and efficient block transfers to the PCI bus.

Clocking and Synchronization

The architecture includes a flexible timing and synchronization circuit that allows the A/Ds to be clocked by internal or external clock sources and a multiboard timing bus. The timing bus includes a clock, a sync, two gate or trigger signals and a PPS signal. The timing bus can be driven by an internal crystal oscillator, a front panel reference input or the LVPECL bus.

A front panel 26-pin LVPECL Clock/Sync connector allows multiple boards to be synchronized. In the slave mode, it accepts differential LVPECL inputs that drive the clock, sync, gate and PPS signals for the internal timing bus.

In the master mode, the LVPECL bus can drive the timing signals for synchronizing multiple boards. Up to two slave 7253Ds or three slave 7353's can be driven from the LVPECL bus master, supporting synchronous sampling and sync functions across all connected boards. More boards can be synchronized with an external clock and sync generator.

PCI Interface

These models include an industry-standard interface fully compliant with PCI bus specifications. The interface includes four separate DMA controllers for efficient transfers to and from the boards.

Data widths of 32 or 64 bits and data rates of 33 and 66 MHz are supported.

XMC Interface

For large systems, multiple 7253's, 7353's or 7253Ds can be chained together via a built-in Xilinx Aurora interface through the P15 XMC connector.

This link creates a board-to-board summation expansion chain for creating larger multi-channel beamformer systems.

Xilinx's Aurora protocol is used to provide an efficient x4, 1.25 GB/sec point-to-point data path between boards.

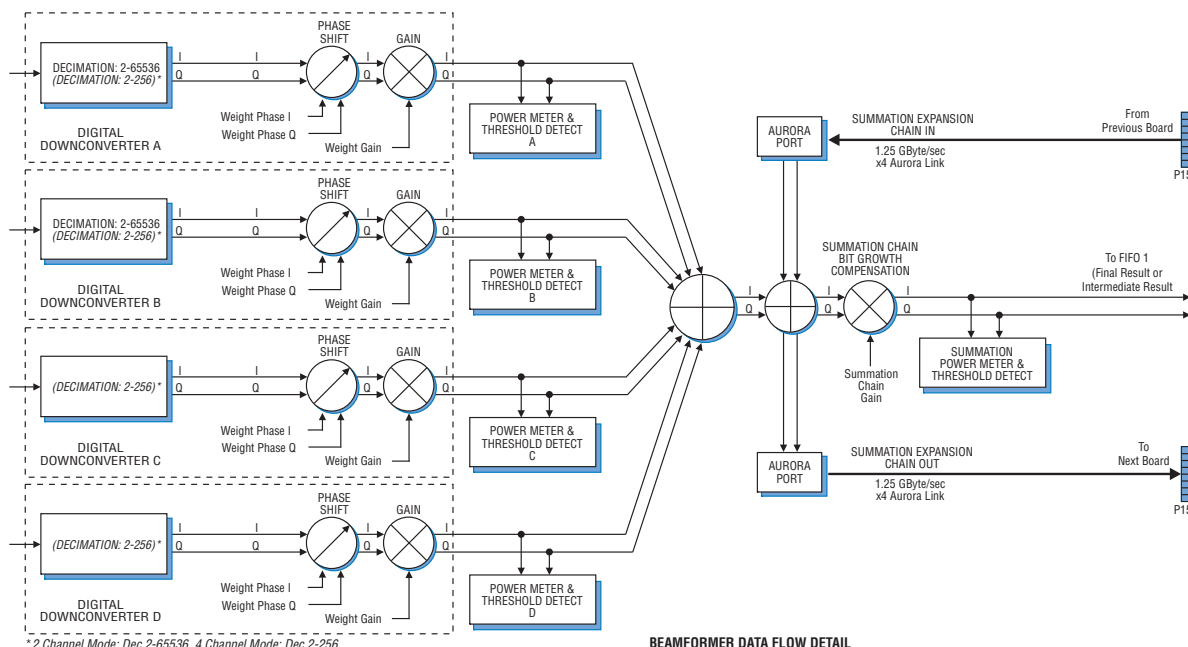

Specifications

Model 7253 or 7353: 4-Channel Beamformer

Model 7253D: 8-Channel Beamformer

Model 7253D shown in the Specifications

Front Panel Analog Signal Inputs (8)

Input Type: Transformer-coupled, front panel female SMC connectors

Transformer Type: Coil Craft WBC4-6TLB

Full Scale Input: +8 dBm into 50 ohms

3 dB Passband: 300 kHz to 700 MHz

A/D Converters (8)

Type: Texas Instruments ADS5485

Sampling Rate: 10 MHz to 200 MHz

Internal Clock: 200 MHz crystal osc.

External Clock: 10 to 200 MHz

Resolution: 16 bits

A/D Data Reduction Mode:

Data from the A/Ds can be decimated by any value between 1 and 4096

Clock Sources (4):

Selectable from onboard crystal oscillator, external reference or LVPECL clocks

External Clocks (4)

Type: Front panel female SMC connector, sine wave, 0 to +10 dBm, AC-coupled 50 ohms

Sync/Gate Bus: 26-pin connector, clock/sync/gate/PPS, input/output LVPECL bus; one gate/trigger and one sync/PPS input TTL signal

Digital Downconverter

Type: IP core for Xilinx Virtex-5

Qty of DDC Channels: 4 or 8

Center Frequency Tuning: 8 tuning words, one for each DDC channel

Center Frequency Tuning Range: DC to f_s with 32 bit resolution

NCO SFDR: -120 dBFS

Channel Phase Offset Adjustment: 32-bit resolution

Channel Gain Adjustment: 32-bit resolution

Input Selection for DDC Banks: Any channel can select any of the four A/Ds

Decimation Range (N):

2-Channel Mode: 2 to 65536

4-Channel Mode: 2 to 256

FIR Filter: Default passband $0.8 \cdot f_s / N$ with 0.2 dB passband ripple and 100 dB adjacent channel rejection

FIR Filter Coefficients: 18 bits, user-programmable (default values provided)

Qty FIR Filter Taps: $28 \cdot N / 8$

Output Format: 24 bits I + 24 bits Q

Output Spectrum Modes: Normal or frequency-reversed

Output Spectrum Offset: No offset or offset by one-half the output bandwidth

Beamformer

Summation: Four or eight channels on-board; multiple boards can be summed via Summation Expansion Chain

Summation Expansion Chain: One chain in and one chain out link via XMC connector using Aurora protocol

Phase Shift Coefficients: I & Q with 16-bit resolution

Gain Coefficients: 16-bit resolution

Channel Summation: 24-bit

Multiboard Summation Expansion: 32-bit

Output Multiplexer and FIFO

Qty Output FIFOs: Eight

FIFO Source Selection: Independent multiplexer selects DDC output or A/D

PCI Interface

PCI Bus: 32 or 64 bits at 66 MHz and 32 or 64 bits at 33 MHz

DMA: 8 channel demand-mode and chaining controller

Local Bus: 64 bits at 33, 66 and 100 MHz

Environmental

Operating Temp: 0° to 50° C

Storage Temp: -20° to 90° C

Relative Humidity: 0 to 95%, non-cond.

Size: Standard 6U cPCI board

Ordering Information

Model	Description
7253	4-Channel DDC with four 200 MHz, 16-bit A/Ds and Beamformer - 6U cPCI
7253D	8-Channel DDC with eight 200 MHz, 16-bit A/Ds and Beamformers - 6U cPCI
7353	4-Channel DDC with four 200 MHz, 16-bit A/Ds and Beamformer - 3U cPCI

Options:

-730 Two-slot heat sink

Contact Pentek for available options.

A/D Performance

Spurious-Free Dynamic Range

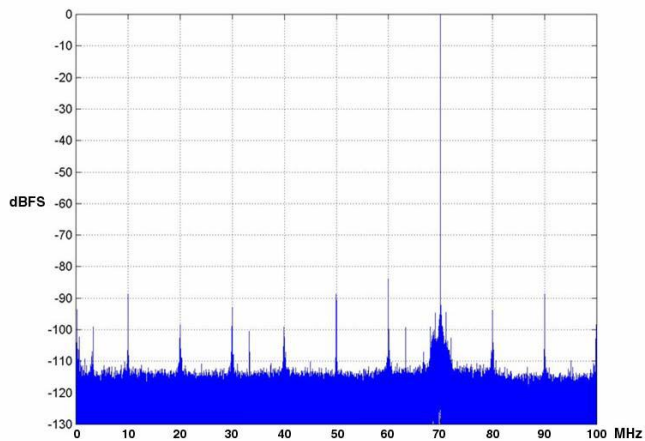

$f_{in} = 70 \text{ MHz}, f_s = 200 \text{ MHz}, \text{Internal Clock}$

Spurious Pickup

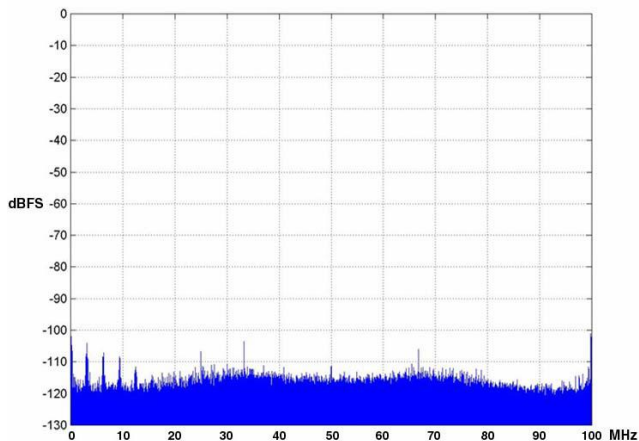

$f_s = 200 \text{ MHz}, \text{Internal Clock}$

Input Frequency Response

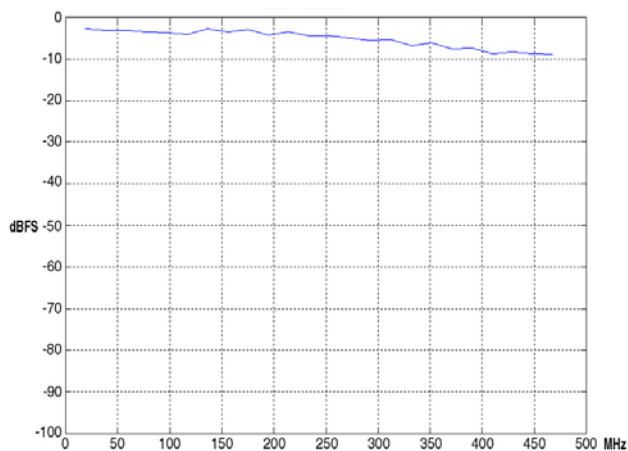

$f_s = 200 \text{ MHz}, \text{Int. Clock}$

Two-Tone SFDR

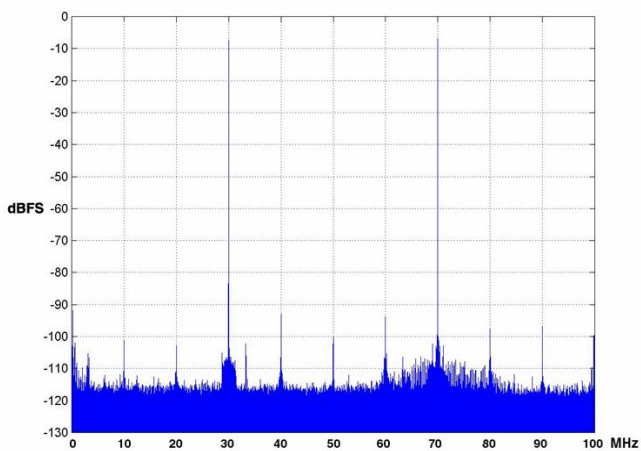

$f_{in1} = 30 \text{ MHz}, f_{in2} = 70 \text{ MHz}, f_s = 200 \text{ MHz}, \text{Int. Clock}$

Adjacent Channel Crosstalk

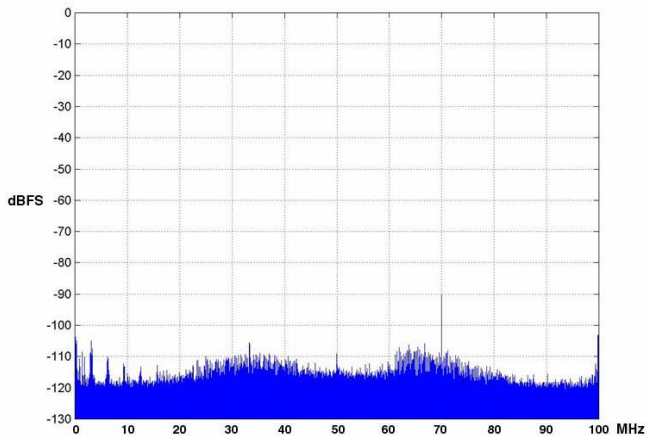

$f_{in} = 70 \text{ MHz}, A_{in} = 0 \text{ dBFS}, f_s = 200 \text{ MHz}, \text{Int. Clock}$

Phase Noise at 70 MHz

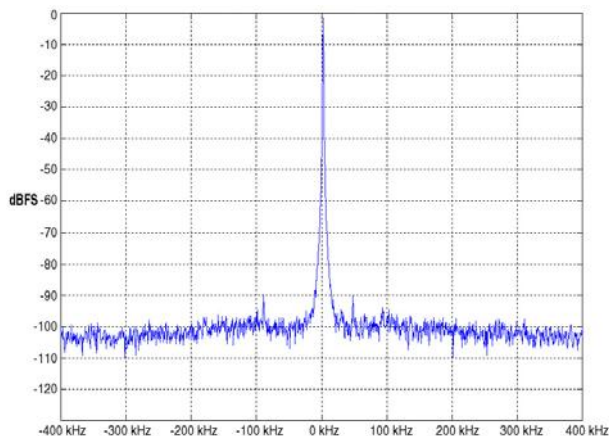

$f_s = 200 \text{ MHz}, \text{Int. Clock}$