

*New!*

# Models 57663 & 58663

# 1100- or 2200-Channel GSM Channelizer with Quad or Octal A/D - 6U OpenVPX



Model 58663



### Features

- Four or eight 180 MHz 16-bit A/Ds
- Two or four banks of 375 DDCs for upper GSM band
- Two or four banks of 175 DDCs for lower GSM band
- PCI Express (Gen. 1 & 2) interface up to x4
- LVPECL clock/sync bus for multiboard synchronization
- Ruggedized and conduction-cooled versions available

### General Information

Models 57663 and 58663 are members of the Cobalt® family of high-performance 6U OpenVPX boards based on the Xilinx Virtex-6 FPGA. They consist of one or two Model 71663 XMC modules mounted on a VPX carrier board.

Model 57663 is a 6U board with one Model 71663 module while the Model 58663 is a 6U board with two XMC modules rather than one.

This quad or octal, high-speed A/D converter with 1100 or 2200 GSM DDCs (digital downconverters) accepts IF signals from an RF tuner. It is ideal for capturing all transmit and receive signals in both upper and lower GSM bands.

### The Cobalt Architecture

The Pentek Cobalt architecture connects all of the board's data converters, digital interfaces, clocks and timing signals to the FPGA. Here, four or eight factory-installed GSM channelizer IP cores are supported with additional FPGA functions including packet formation, four or eight DMA controllers, PCIe interface, gating, and triggering.

These models are complete, full-featured subsystems, ready to use with no additional FPGA development required.

### A/D Converter Stage

The front end accepts four or eight analog IF inputs on front panel SSMC connectors

with transformer coupling into four or eight Texas Instruments ADS5485 200 MHz, 16-bit A/D converters clocked at 180 MHz.

The digital outputs are delivered into the FPGA for GSM channelizer signal processing.

### Clocking and Synchronization

The internal timing bus provides all timing and synchronization required by the A/D converters. It includes clock, sync and gate or trigger signals. One or two on-board clock generators accept external 180 MHz sample clocks from the front panel SSMC connectors. The clocks can be used directly by the A/Ds or divided by a built-in clock synthesizer circuit. In an alternate mode, the sample clock can be sourced from an on-board 180 MHz voltage-controlled crystal oscillator. In this mode, the front panel SSMC connector can be used to provide a reference clock, typically 10 MHz, for synchronizing the internal oscillator.

A front panel 26-pin LVPECL Clock/Sync connector allows multiple boards to be synchronized. In the slave mode, it accepts LVPECL inputs that drive the clock, sync and gate signals. In the master mode, the LVPECL bus can drive the timing signals for synchronizing multiple boards.

Multiple boards can be driven from the LVPECL bus master, supporting synchronous sampling and sync functions across all connected boards. ➤

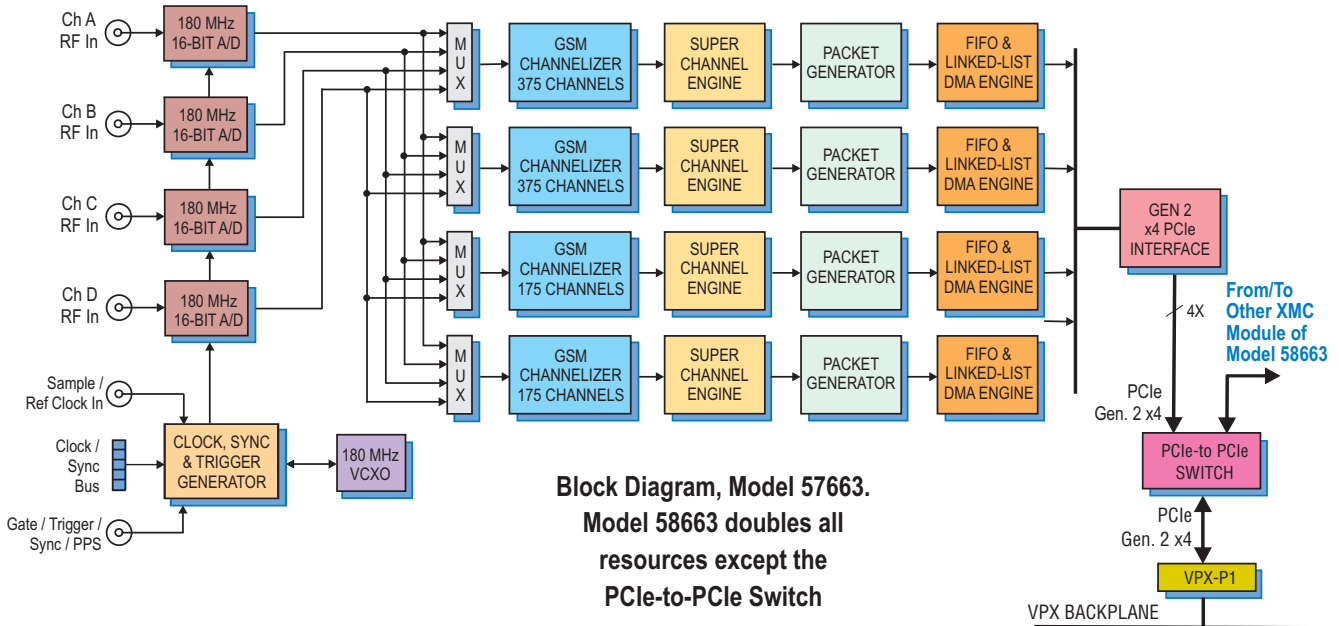

**Block Diagram, Model 57663.**  
**Model 58663 doubles all resources except the PCIe-to-PCIe Switch**

## ► GSM Channelizer Cores

These models contain four or eight powerful GSM channelizer cores, two or four with 375 DDCs and two or four with 175 DDCs. Flexible input routing allows the independent, non-blocking assignment of any A/D converter to serve as the input source for any of four GSM channelizers.

The 375-channel cores are designed for the upper GSM bands which contain two 75 MHz bands, one for uplink and one for downlink. The 175-channel cores are designed for the lower GSM band and handle two 35 MHz bands, one for uplink and one for downlink.

Before connection to these models, the GSM RF bands must first be separately downconverted to an IF frequency centered at 45 MHz, 135 MHz or 225 MHz using an external analog RF tuner.

These IF signals are then digitized by the four or eight A/Ds at 180 MS/sec in the first, second, or third Nyquist zones, respectively. In order to prevent aliasing, careful filtering must insure that no signals appear in adjacent Nyquist zones.

Each of the channelizers is designed to accept real digital samples of the IF signal from the A/D converter. The first stage of the GSM channelizer is a complex mixer that shifts the center frequency of the IF signal (45, 135 or 225 MHz) to 0 Hz, producing complex I+Q samples.

The DDCs split the IF input into either 175 or 375 parallel DDC baseband channels, equally spaced at 200 kHz. The DDC output sample rate is resampled to precisely  $180 \text{ MHz} \times 13 / 2160$ , or approximately 1.08333 MHz. This is four times the GSM symbol rate of 270.666 kSymbols/sec. The output passband of each DDC channel is nominally 160 kHz, with filter characteristics fully defined in the channel response chart in the specifications.

## Channelizer Output Formatting

All 1100 DDCs generate parallel, complex output sample streams. At a sample rate of 1.08333 MS/sec, this represents an aggregate output rate of 9.533 GB/sec, greatly exceeding the 4 GB/sec peak rate of PCIe Gen 2 x8 interface.

To mitigate this situation, every four DDC channels are frequency-multiplexed into a single "superchannel". This is allowed because of the 4x over sampling, and results in a reduction of the aggregate traffic by a factor of 4 to 2.383 GB/sec.

During superchannel formation, the 24-bit I + 24-bit Q output samples from four DDCs are summed to superchannel samples with 26-bits I + 26-bits Q.

As a result, the two 375-channel banks each deliver 94 superchannels, while the two 175-channel banks each deliver 44 superchannels. The last superchannel in each bank only contains three DDC channels.

A superchannel enable mask word containing one enable bit for each superchannel allows independent selection of which superchannel samples are delivered across the PCI-X bus. There are four superchannel mask words, one for each bank.

## Superchannel Packets and Headers

Superchannel packets are formed by appending enabled superchannel samples sequentially from each bank. Once complete, a unique superchannel packet header is inserted at the beginning of each packet for identification.

The header contains a time stamp, a sequential packet count, the number of enabled superchannels, the DMA channel identifier, and other information. By inspecting the header, the remaining superchannel data "payload" samples can be identified and recovered by the host.

## PCI Express Interface

These models include an industry-standard interface fully compliant with PCI Express Gen. 1 and 2 bus specifications. Supporting PCIe links up to x4, the interface includes multiple DMA controllers for efficient transfers to and from the board.

The PCIe interface is also used as the programming interface for all status and control between these models and host. ►

**Specifications**

**Model 57663:** 4 A/Ds, 1100 Channels

**Model 58663:** 8 A/Ds, 2200 Channels

**Front Panel Analog Signal Inputs (4 or 8)**

**Input Type:** Transformer-coupled, front panel female SSMC connectors

**Transformer Type:** Coil Craft WBC4-6TLB

**Full Scale Input:** +8 dBm into 50 ohms

**3 dB Passband:** 300 kHz to 700 MHz

**A/D Converters (4 or 8)**

**Type:** Texas Instruments ADS5485

**Sampling Rate:** 10 MHz to 200 MHz

**Resolution:** 16 bits

**Sample Clock Sources (1 or 2)**

On-board clock synthesizer

**Clock Synthesizers (1 or 2)**

**Clock Source:** Selectable from on-board 180 MHz VCXO, front panel external clock or LVPECL timing bus

**Synchronization:** VCXO can be locked to an external 10 MHz system reference

**External Clocks (1 or 2)**

**Type:** Front panel female SSMC connector, sine wave, 0 to +10 dBm, 50 ohms, AC-coupled, accepts 180 MHz sample clock or 10 MHz system reference

**Timing Bus (1 or 2):** 26-pin front panel connector; LVPECL bus includes, clock/sync/gate/PPS inputs and outputs; TTL signal for gate/trigger and sync/PPS inputs

**External Trigger Inputs (1 or 2)**

**Type:** Front panel female SSMC connector, LVTTTL

**Function:** Programmable functions include: trigger, gate, sync and PPS

**GSM Channel Banks (1 or 2)**

**DDCs per bank:** two banks of 175

DDCs and two banks of 375 DDCs

**Overall bandwidth per bank:** 35 MHz & 75 MHz for 175- & 375-channel banks

**IF (Center) Freq:** 45, 135 or 225 MHz

**DDC Channels**

**Channel Spacing:** 200 kHz, fixed

**DDC Center Freqs:** IF Freq  $\pm k * 200$  kHz, where  $k = 0$  to 87, or 0 to 187

**DDC Channel Filter Characteristics**

< 0.1 dB passband flatness across  $\pm 80$  kHz from center (160 kHz BW)

> 18 dB attenuation at  $\pm 100$  kHz

> 78 dB attenuation at  $\pm 170$  kHz

> 83 dB attenuation at  $\pm 600$  kHz

> 93 dB attenuation at  $\pm 800$  KHz

> 96 dB attenuation at  $> \pm 3$  MHz

**DDC Output Rate  $f_s$ :** Resampled to

180 MHz\*13/2160 = 1.0833333 MS/sec

**DDC Data Output Format:**

24 bits I + 24 bits Q

**Superchannels**

**Content:** Four consecutive DDC channels are frequency-offset from each other and then summed together

**Frequency Offsets for each DDC:**

First:  $-f_s/4$  (-270.8333 kHz)

Second: 0 Hz

Third:  $+f_s/4$  (+270.8333 kHz)

Fourth:  $+f_s/2$  (+541.666 kHz)

**Superchannel Sample Rate:**  $f_s$

**Superchannel Output Format:**

26 bits I + 26 bits Q

**Number of Superchannels per Bank:**

175-Channel banks: 44; 375-Channel banks: 94

**Field Programmable Gate Arrays (1 or 2)**

Xilinx Virtex-6 XC6VSX315T

**PCI-Express Interface**

**PCI Express Bus:** Gen. 1 or 2: x4

**Environmental:** Level L1 & L2 air-cooled;

Level L3 ruggedized, conduction-cooled

**Size:** 3.937 in. x 6.717 in. (100 mm x 170.6 mm)

**Ordering Information**

Model	Description
57663	1100-Channel GSM Channelizer with Quad A/D - 6U VPX
58663	2200-Channel GSM Channelizer with Octal A/D - 6U VPX

*Contact Pentek for availability of rugged and conduction-cooled versions*